

A350
TECHNICAL TRAINING MANUAL
MAINTENANCE COURSE - T1+T2 - RR Trent XWB
Landing Gear

This document must be used for training purposes only

Under no circumstances should this document be used as a reference

It will not be updated.

All rights reserved

No part of this manual may be reproduced in any form,
by photostat, microfilm, retrieval system, or any other means,
without the prior written permission of AIRBUS S.A.S.



AIRBUS Environmental Recommendation

Please consider your environmental responsibility before printing this document.

LANDING GEAR

Landing Gears and Doors Description (2/3)	2
Load Exceedance Analysis System Description (2)	26
Landing Gear Normal Extension/Retraction System Description (2/3)	32
Landing Gear Monitoring System Description (2/3)	42
Ground Door Opening System Description (2)	52
Landing Gear Alternate Extension System Description (3)	62
Landing Gears Control and Indicating (2/3)	74
Wheels and Braking Systems Description (2)	84
Normal Braking System Description (3)	100
Alternate and Emergency Braking Systems Description (3)	110
Parking and Ultimate Braking Systems Description (3)	114
Braking Systems Maintenance (2/3)	116
Landing Gear Management System Description (2/3)	120
Braking System Control and Indicating (2)	128
Braking System Control and Indicating (3)	138
Nose Wheel Steering System Description (2)	148
Nose Wheel Steering System Description (3)	158
Nose Wheel Steering Maintenance (2/3)	180
Nose Wheel Steering Control and Indicating (2)	190
Nose Wheel Steering Control and Indicating (3)	196

LANDING GEARS AND DOORS DESCRIPTION (2/3)

Main Landing Gear and Doors

The Main Landing Gear (MLG) bays are closed by three doors on each side:

- The main door
- The fixed fairing
- The hinged door.

The main door is operated by the hydraulic actuator.

The fixed fairing door and the hinged door are mechanically attached to the leg.

Free-fall ramps and rods help the MLGs to slide during alternate extension.

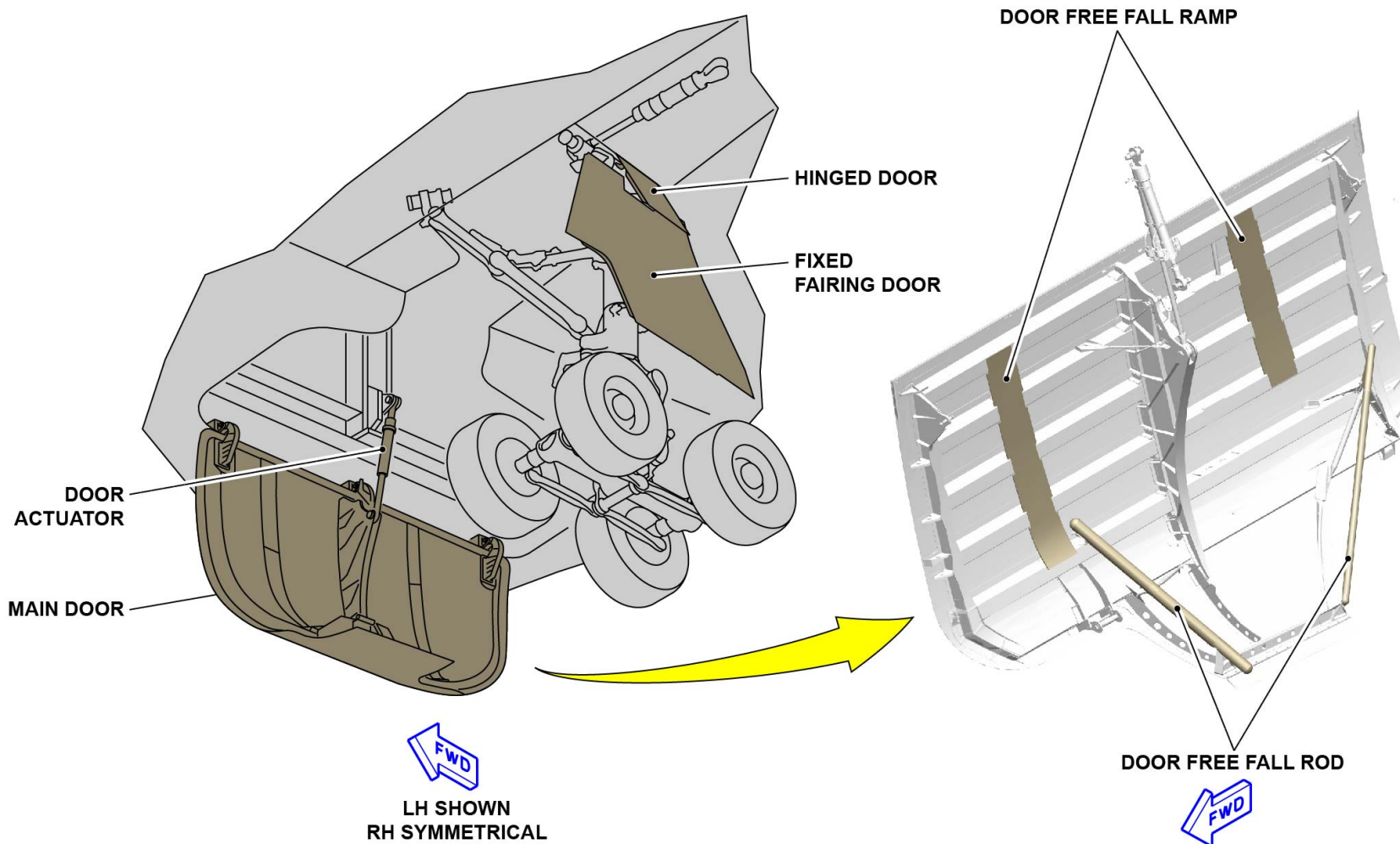
MAIN LANDING GEAR AND DOORS

V1813401 - V01T0M0 - VM32D1GEARS3001

LANDING GEARS AND DOORS DESCRIPTION (2/3)

Main Landing Gear and Doors

When the MLG doors are closed, the maintenance personnel can stay on the MLG doors to do maintenance tasks in the MLG bay. The doors must be safetied with a safety pin.

The safety pin is engaged in the door uplock assembly and prevents any door uplock release.

NOTE: No aircraft system monitors if the safety pin is in the uplock assembly.

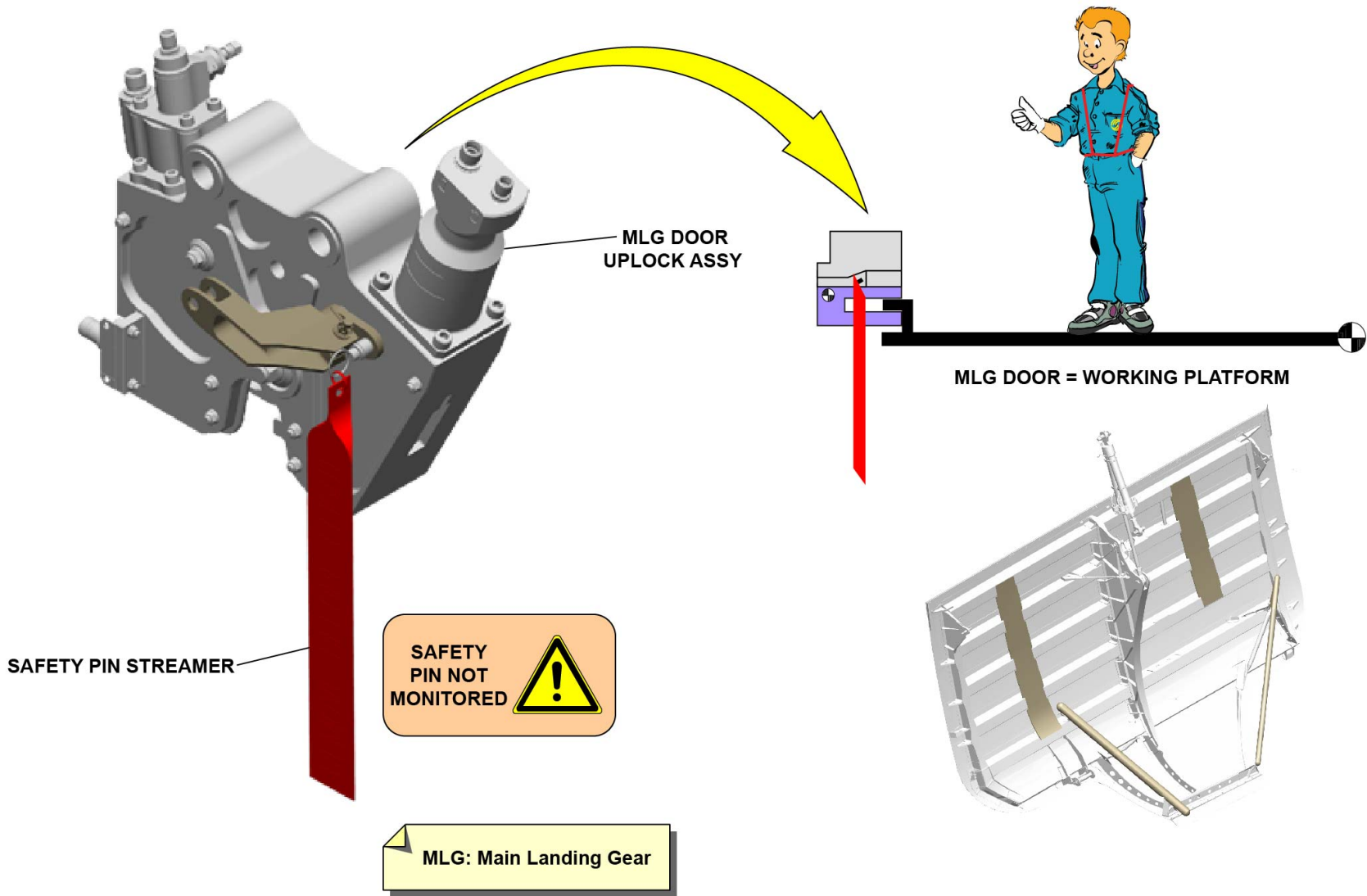

MAIN LANDING GEAR AND DOORS

V1813401 - V01T0M0 - VM32DIGEARS3001

LANDING GEARS AND DOORS DESCRIPTION (2/3)

Main Landing Gear

The MLGs give support for the aircraft on the ground and absorb the loads during taxi, take-off and landing.

Each MLG has:

- An oleo-pneumatic shock-absorber leg made of a main fitting and a sliding tube
- A four-wheel bogie-beam assembly
- A torque link
- Forward and aft side stays with their lock links
- Two lock stay actuators
- Two pairs of down-lock springs
- A retraction actuator
- A hydraulic pitch trimmer.

The MLG has a shock absorber assembly (main fitting and sliding tube) with a four-wheel bogie. The shock absorber is single stage, with oil and nitrogen gas.

Access to the MLG attachments and to some hydraulic lines is possible through an over-wing access panel.

Torque links keep the main fitting and the sliding tube correctly aligned.

The bogie pitch-trimmer actuator keeps the bogie beam in the correct position for retraction when the shock absorber is extended.

The two side stay assemblies hold the MLG in the extended position.

The side stay assemblies are attached to the wing rear spar and the gear beam to apply the loads equally. Down-lock springs and actuators are installed between the lock links (also known as lockstays) and side stays. They keep the lock links in the over center and locked position after extension.

It is possible to install a lock-pin in the center of the lock link when the gear is in the down position.

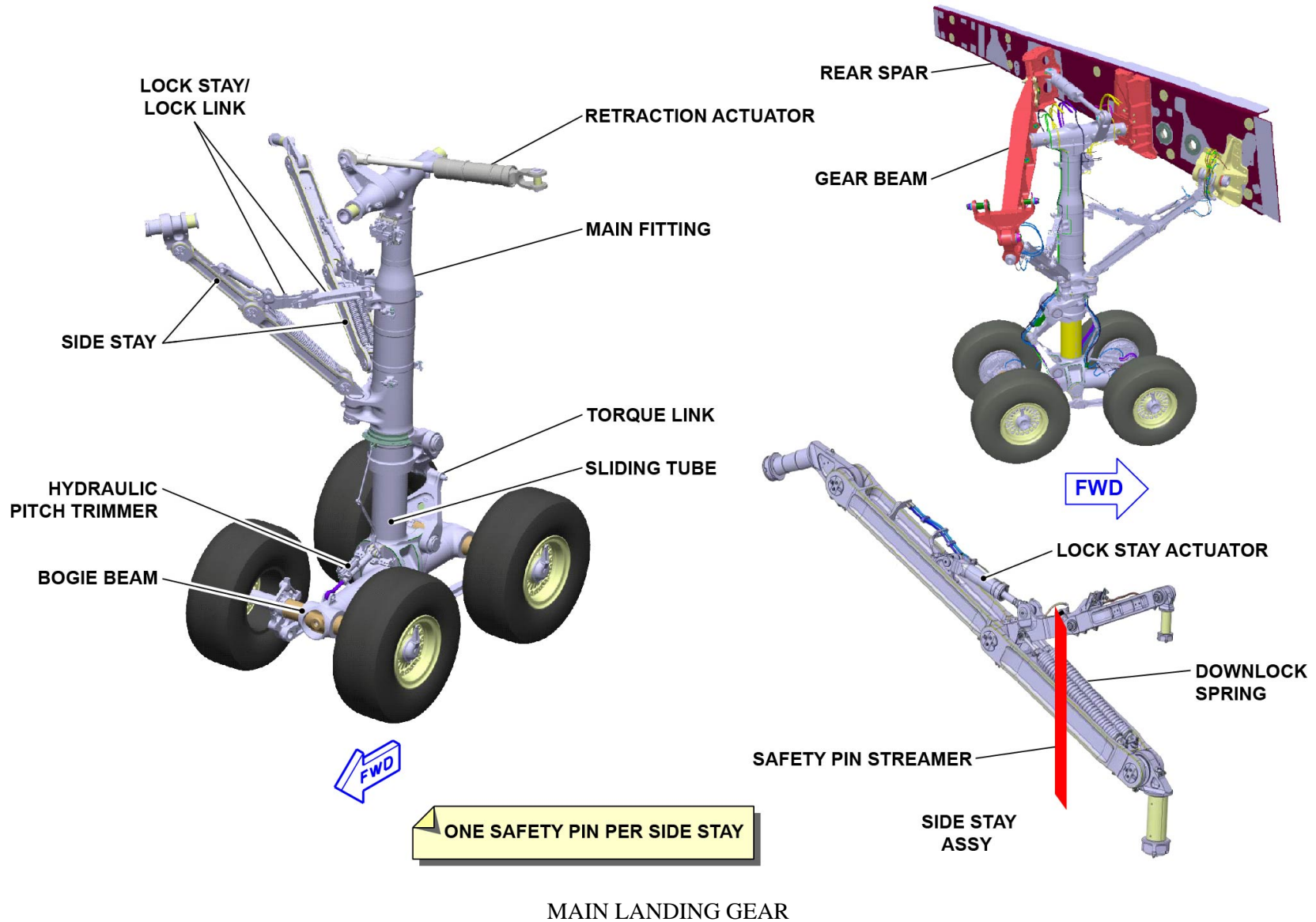

V1813401 - V01T0M0 - VM32D1GEARS3001

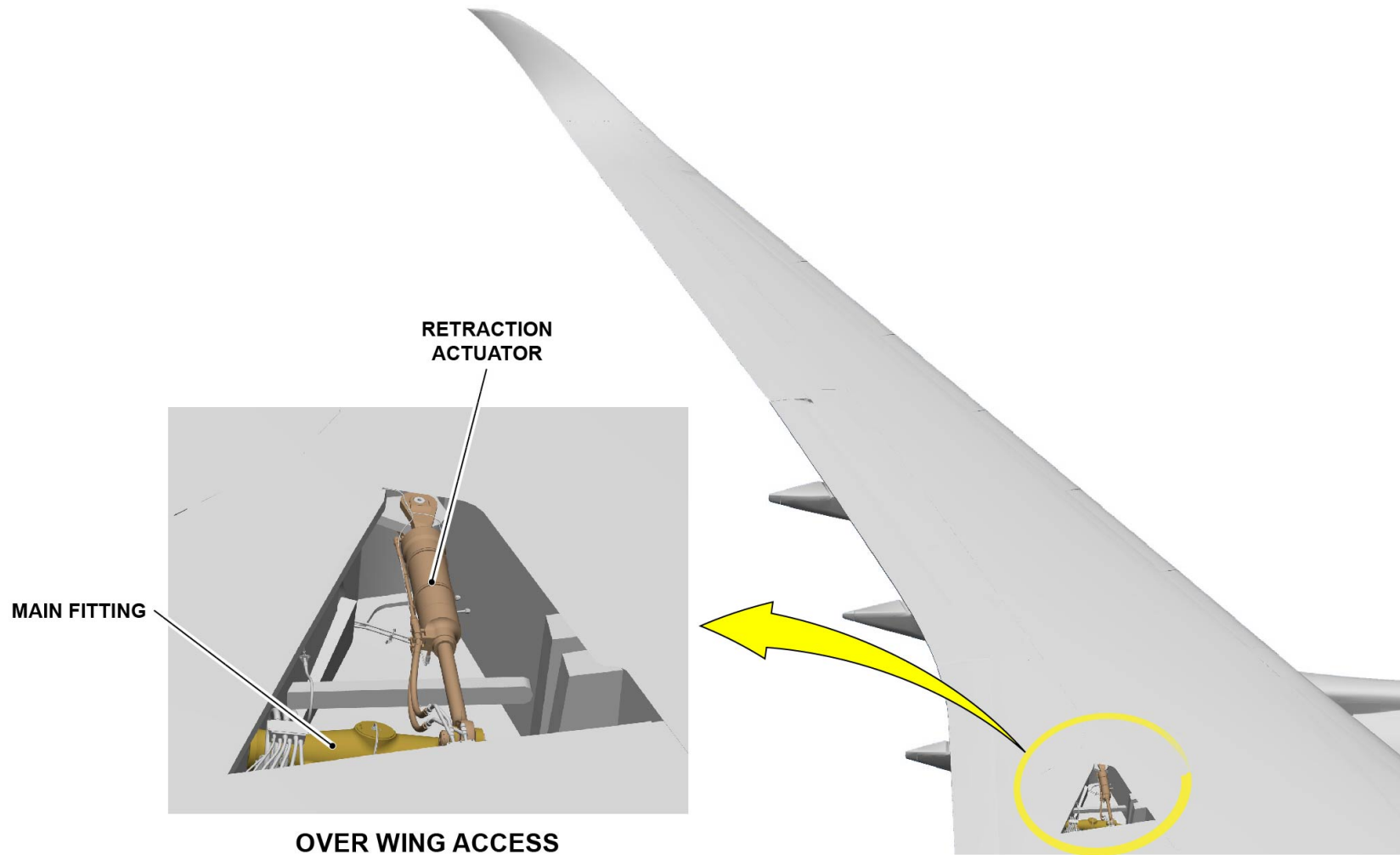

V1813401 - V01T0M0 - VM32DIGEARS3001

This Page Intentionally Left Blank

LANDING GEARS AND DOORS DESCRIPTION (2/3)

Main Landing Gear

Each bogie beam has a front and aft jacking dome. Brake tie rods are attached to the bogie beam. They transmit the braking effect from the brake units to the aircraft through the MLG.

The bogie axle sleeves have a wear surface for the brake units and wheels. On the bogie axles, a layer of temperature-sensitive paint shows if the axles became too hot after a high energy braking.

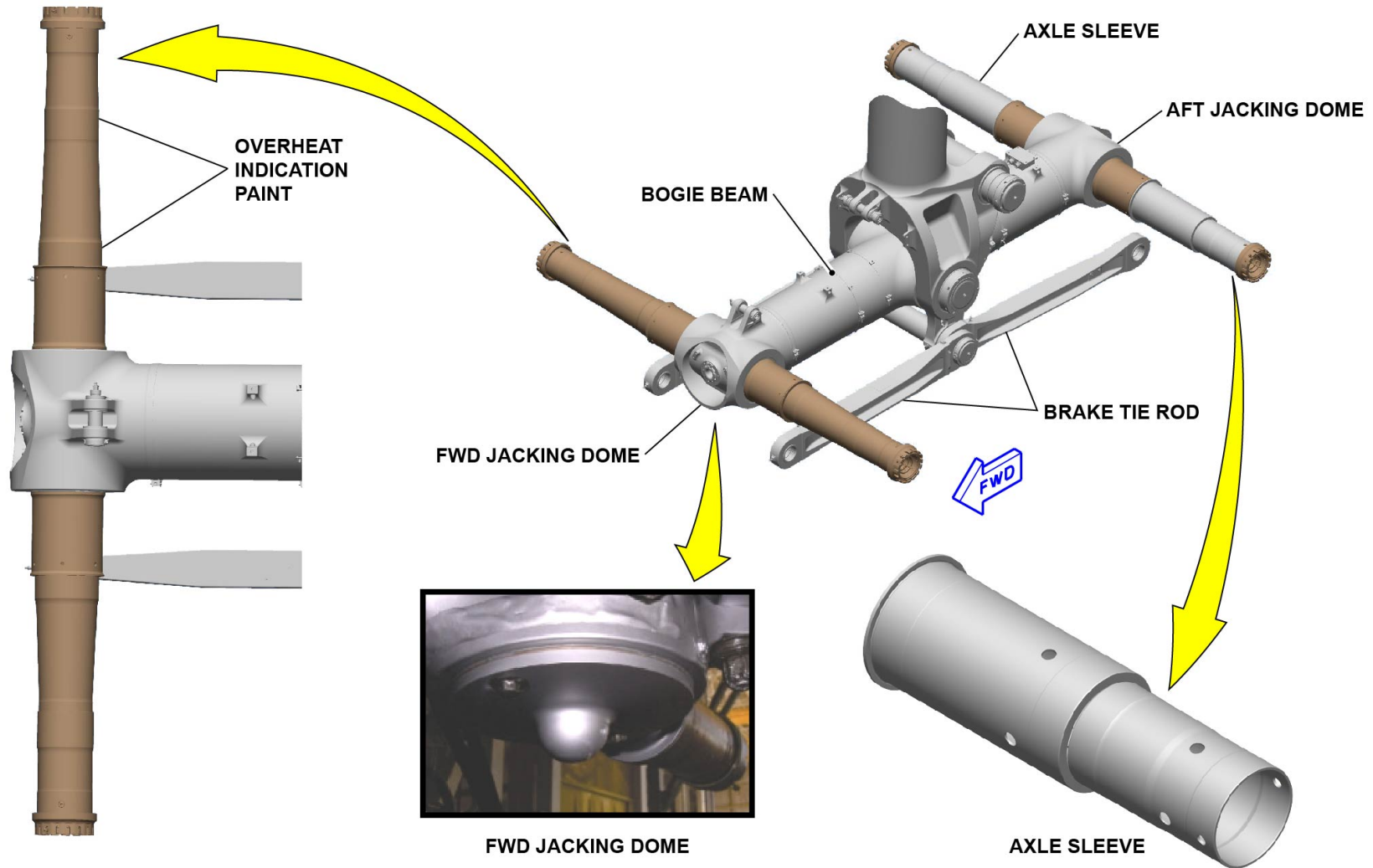

FWD JACKING DOME

AXLE SLEEVE

MAIN LANDING GEAR

V1813401 - V01T0M0 - VM32DIGEARS3001

LANDING GEARS AND DOORS DESCRIPTION (2/3)

MLG Pitch Trimmer Actuator

The MLG bogie pitch-trim actuator is an hydraulic actuator, installed between the sliding tube and the forward end of the bogie beam. It holds the bogie beam in position to:

- Make sure the wheels are correctly positioned in the MLG bay
- Absorb bogie pitch oscillations during landing and taxi.

A bleed screw lets maintenance bleed air from the actuator.

A fuse prevents the loss of hydraulic system fluid. If an hydraulic fluid leak occurs downstream of the hydraulic fuse, the fuse automatically closes to prevent heavy leakage. The hydraulic fuse is then held closed. The leak must stop and the reset lever must be reset before the hydraulic fuse will open again.

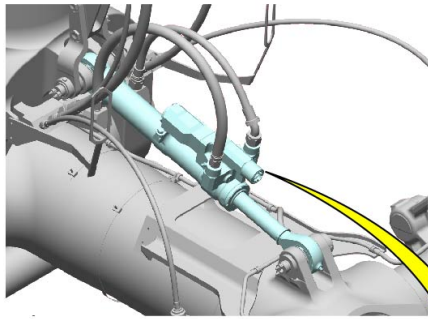

MLG BOGIE PITCH TRIMMER ACTUATOR

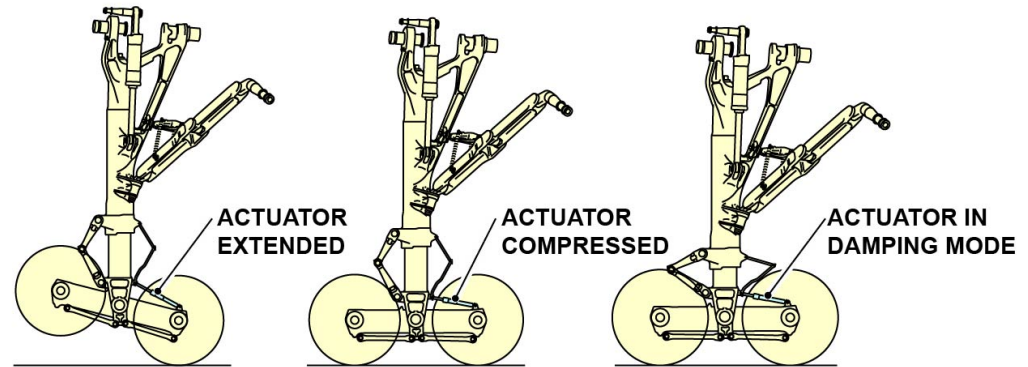
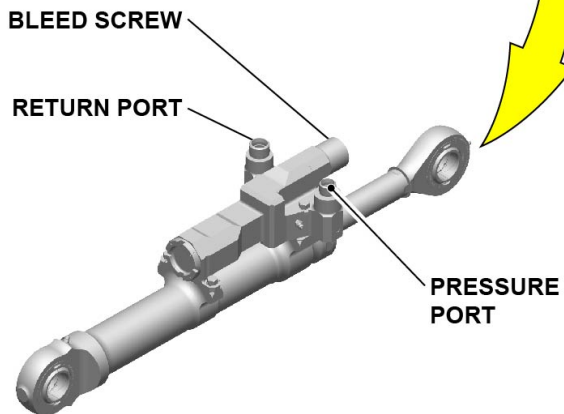

BOGIE ALIGNMENT

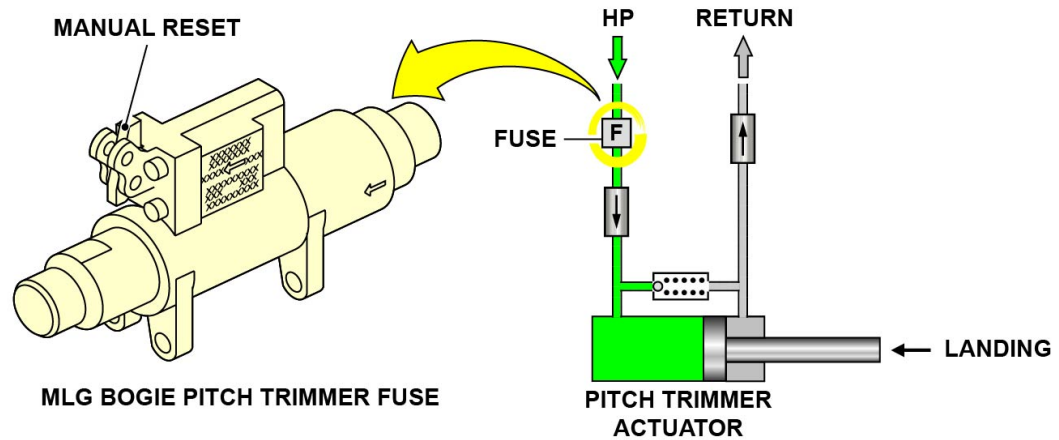

MLG BOGIE PITCH TRIMMER FUSE

PITCH TRIMMER ACTUATOR

MLG PITCH TRIMMER ACTUATOR

V1813401 - V01T0M0 - VM32D1GEARS3001

LANDING GEARS AND DOORS DESCRIPTION (2/3)

MLG Shock Absorber

The shock absorber has an upper outer cylinder (main fitting) and a lower inner piston (sliding tube).

It is a single-stage oleo-pneumatic unit in which there is no separation of the gas (HP nitrogen) and oil.

There is a gas (HP nitrogen) filling port at the top of the main fitting.

There is an oil filling port at the bottom of the main fitting.

A changeover valve is installed on the lower part of the main fitting.

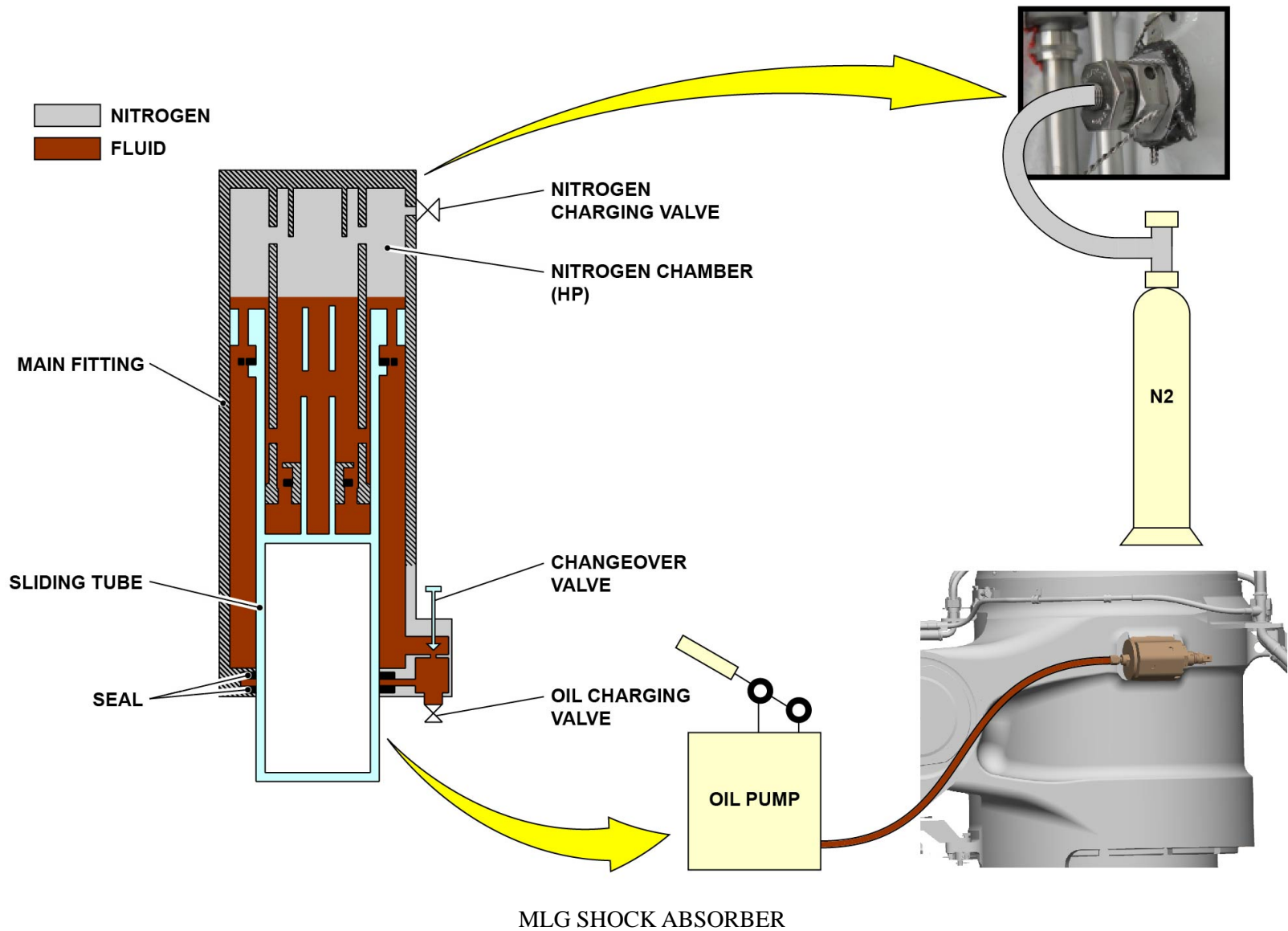

V1813401 - V01T0M0 - VM32DIGEARS3001

LANDING GEARS AND DOORS DESCRIPTION (2/3)

MLG Changeover Valve

Dynamic seals in the main fitting keep the oil and nitrogen pressure inside the cylinder. In the usual configuration, only the lower (primary) seal is used to seal the shock absorber. If the primary seal becomes unserviceable, it is possible to use the top (secondary) seal. To do this, the changeover valve is manually operated.

In usual operation, the secondary seal has the same oil pressure on each side of the seal to prevent its operation. If there is a leak on the primary seal, the changeover valve is operated to:

- Let equal pressure go to the two sides of the primary seal to prevent its operation
- Close the oil pressure from one side of the secondary seal which activates it and seal the shock absorber.

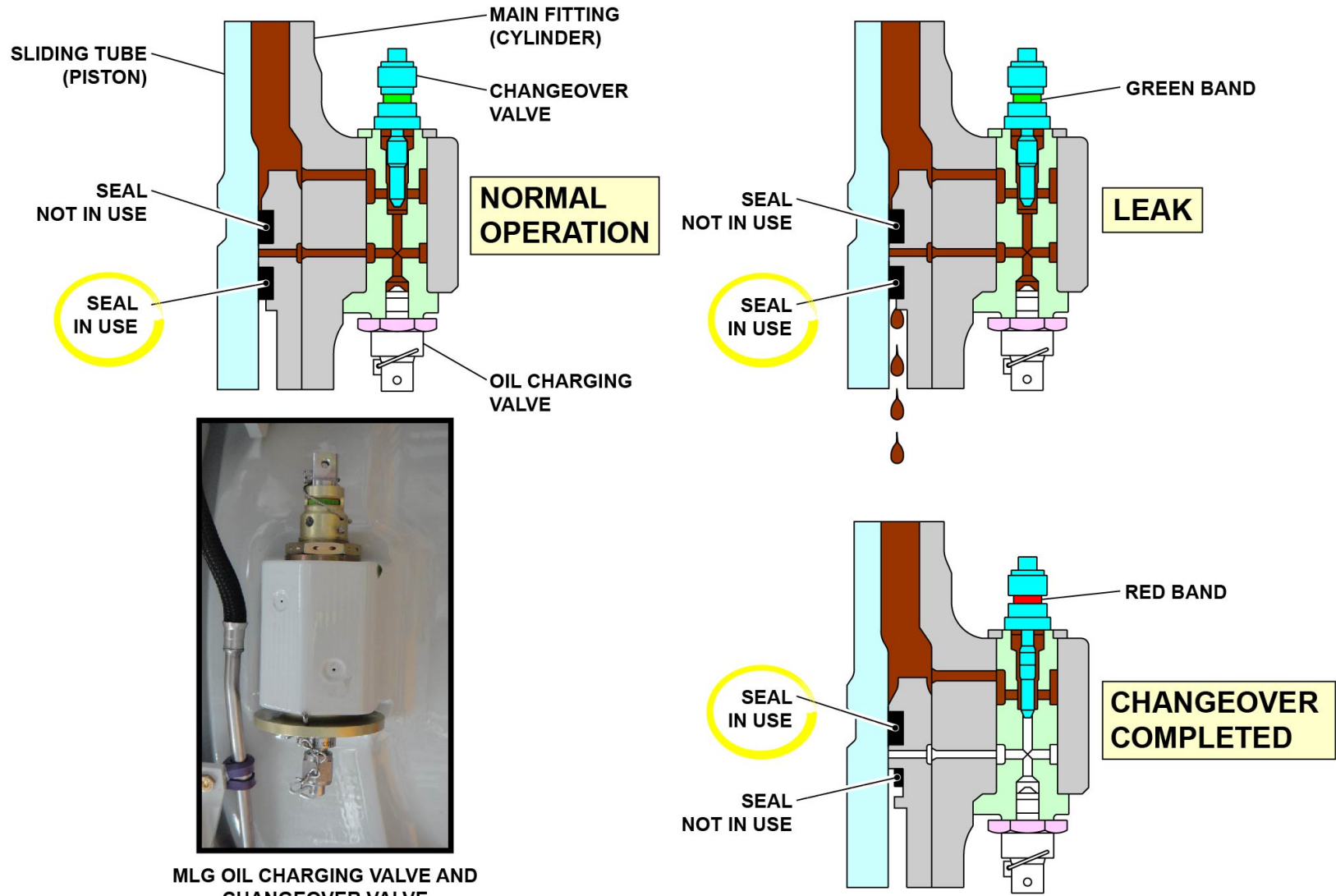

MLG OIL CHARGING VALVE AND CHANGEOVER VALVE

MLG CHANGEOVER VALVE

V1813401 - V01T0M0 - VM32DIGARS3001

LANDING GEARS AND DOORS DESCRIPTION (2/3)

Nose Landing Gear and Doors

The Nose Landing Gear (NLG) bay is closed by four doors in groups of two pairs:

- The forward pair of doors, hydraulically operated with actuators
- The rear pair of doors, mechanically operated by the landing gear movement.

Free-fall ramps help movement during alternate extension.

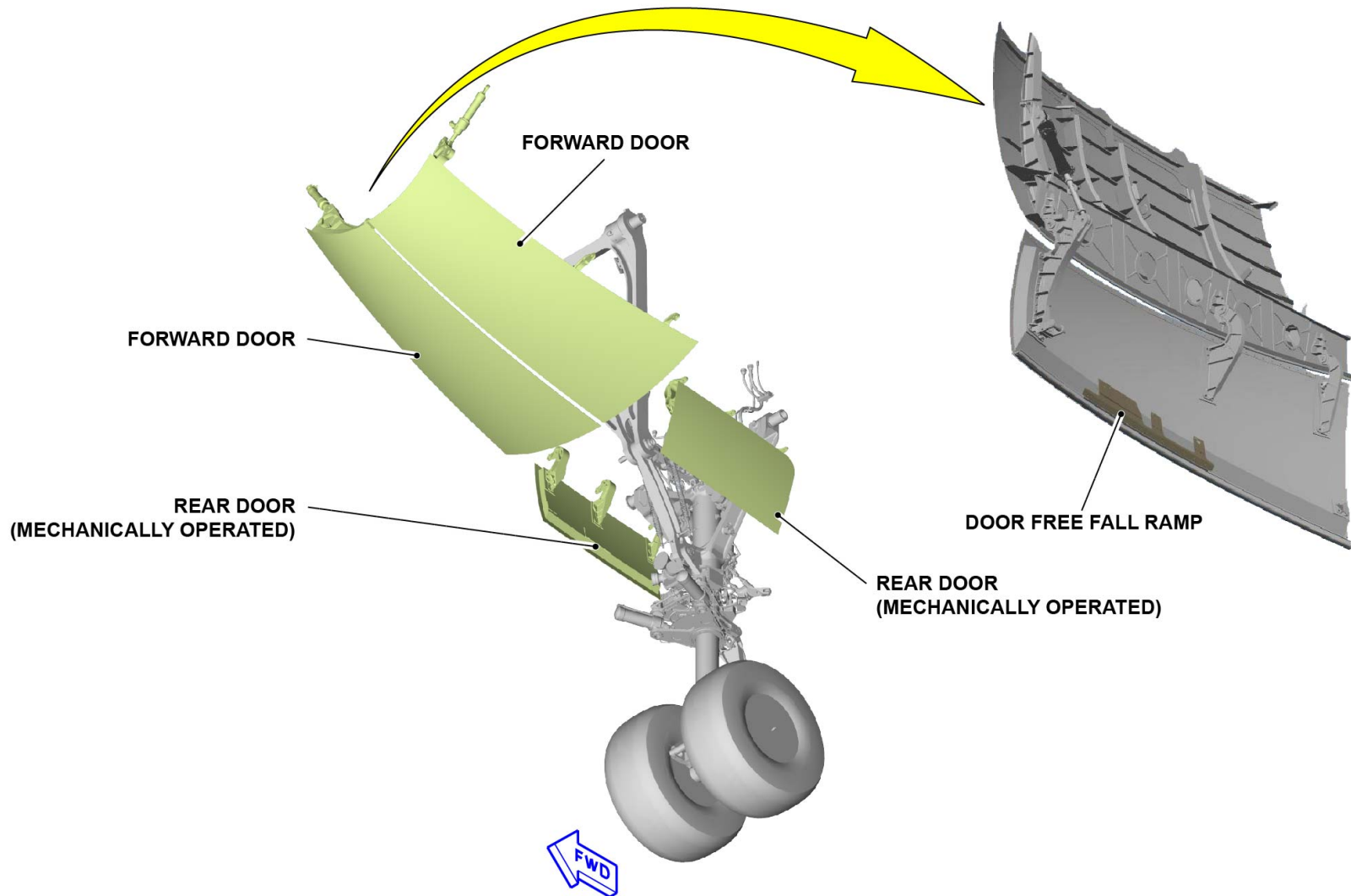

NOSE LANDING GEAR AND DOORS

V1813401 - V01T0M0 - VM32D1GEARS3001

LANDING GEARS AND DOORS DESCRIPTION (2/3)

Nose Landing Gear

The NLG gives support for the aircraft on the ground and absorbs the loads during taxi, take-off and landing.

The NLG has:

- A main fitting and a sliding tube (shock absorber)
- A torque link
- A drag stay
- Lock links
- A lock stay actuator
- Down-lock springs
- A retraction actuator
- Steering actuators.

The shock absorber is an oleo-pneumatic type shock absorber. It has a main fitting (cylinder) and a sliding tube (piston).

The drag stay assembly has two parts: the upper and the lower part. It keeps the NLG leg stable when the NLG is in the extended position.

During extension, the tension in the down-lock springs and the hydraulic pressure in the down-lock actuator put the lock link in its over-center locked position.

During a free fall, the tension in the down-lock springs make sure that the lock links will mechanically go to the over-center locked position. It is possible to install a lock-pin in the center of the lock links when the gear is in the down position.

The nose wheels are steered by twin double-action hydraulic actuators, which are attached to the main fitting.

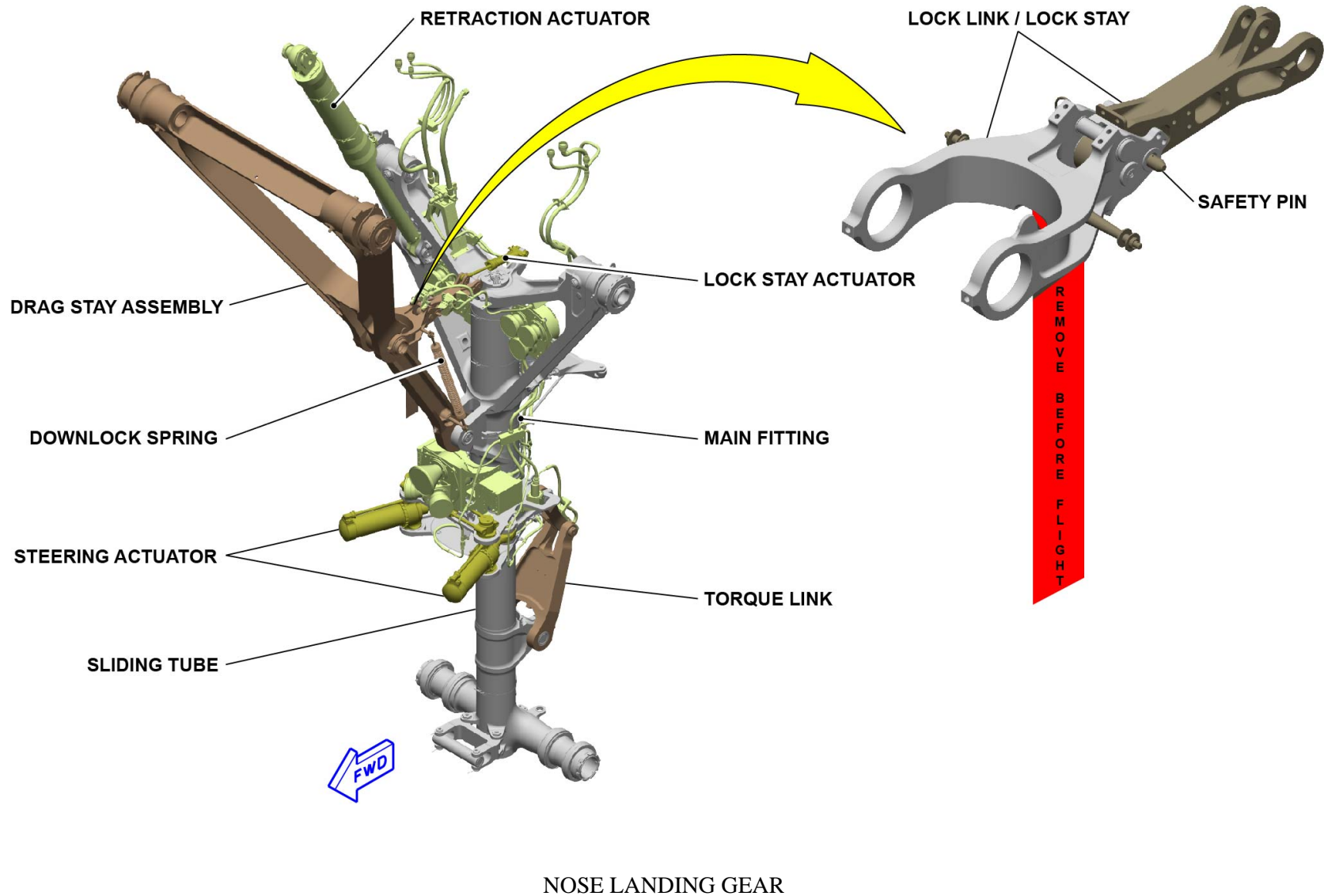

V1813401 - V01T0M0 - VM32D1GEARS3001

LANDING GEARS AND DOORS DESCRIPTION (2/3)

NLG Axle Sleeve and Fittings

The sliding tube has a jacking dome. Two axle sleeves have a wear surface for the wheels. Towing operations can be done with a towbarless tractor or with a tow bar. Because of this, forward and aft tow bar fittings and brackets are installed or not in relation to the operator's selection.

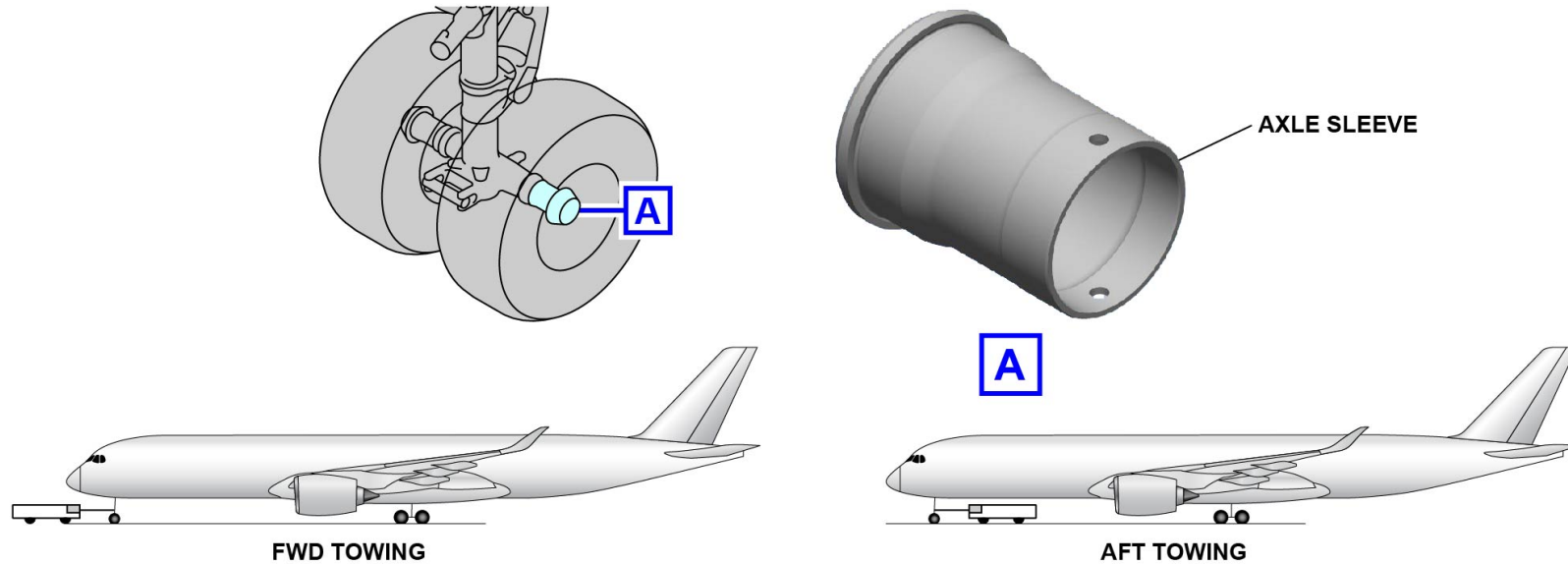

TOWING TRACTOR AND TOW BAR

AFT TOW FITTING AND BRACKET



NLG AXLE SLEEVE AND FITTINGS

V1813401 - V01T0M0 - VM32D1GEARS3001

LANDING GEARS AND DOORS DESCRIPTION (2/3)

NLG Shock Absorber

The shock absorber has an upper outer cylinder (main fitting) and a lower inner piston (sliding tube). It is a single-stage oleo-pneumatic unit in which there is no separation of the gas and oil. There is a gas filling port at the top of the main fitting. There is an oil filling port at the bottom of the main fitting.

A changeover valve is installed on the lower part of the main fitting. The operation and activation of the changeover valve is similar to the MLGs.

NITROGEN
 FLUID

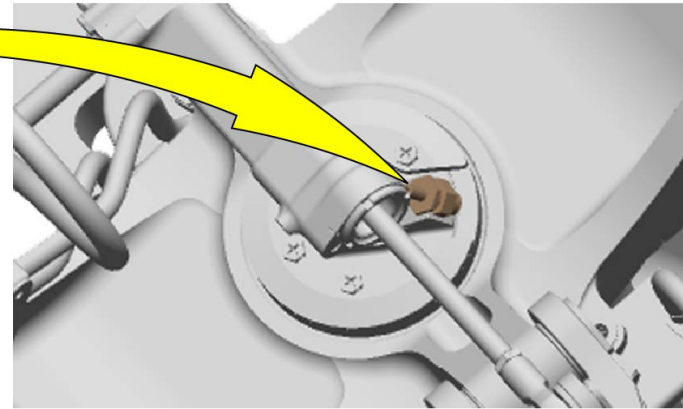
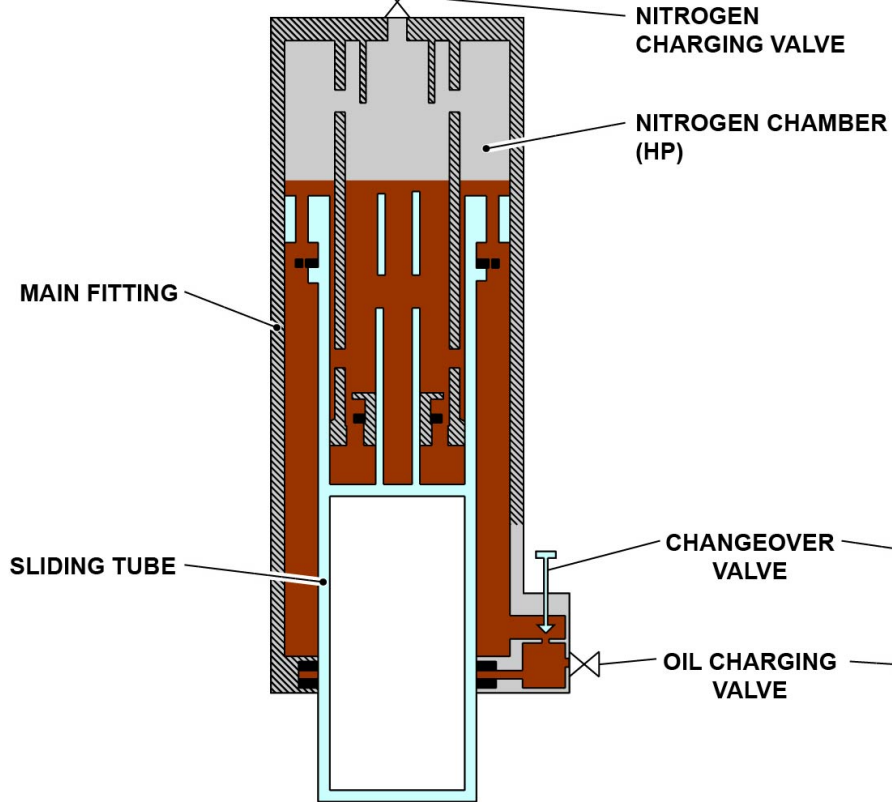

NO BAND = PRIMARY SEAL ACTIVE
RED BAND = SPARE SEAL ACTIVATED

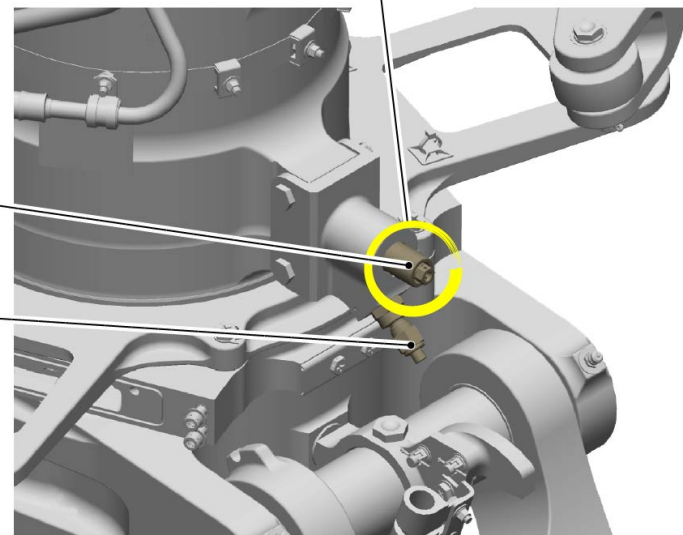

NLG SHOCK ABSORBER

V1813401 - V01T0M0 - VM32DIGEARS3001

LOAD EXCEEDANCE ANALYSIS SYSTEM DESCRIPTION (2)

Exceedance Detection

An exceedance in flight (such as heavy turbulence) or on the ground (such as a hard landing) is recorded in the Aircraft Condition Monitoring System (ACMS) Smart Access Recorder (SAR)/Quick Access Recorder (QAR) files.

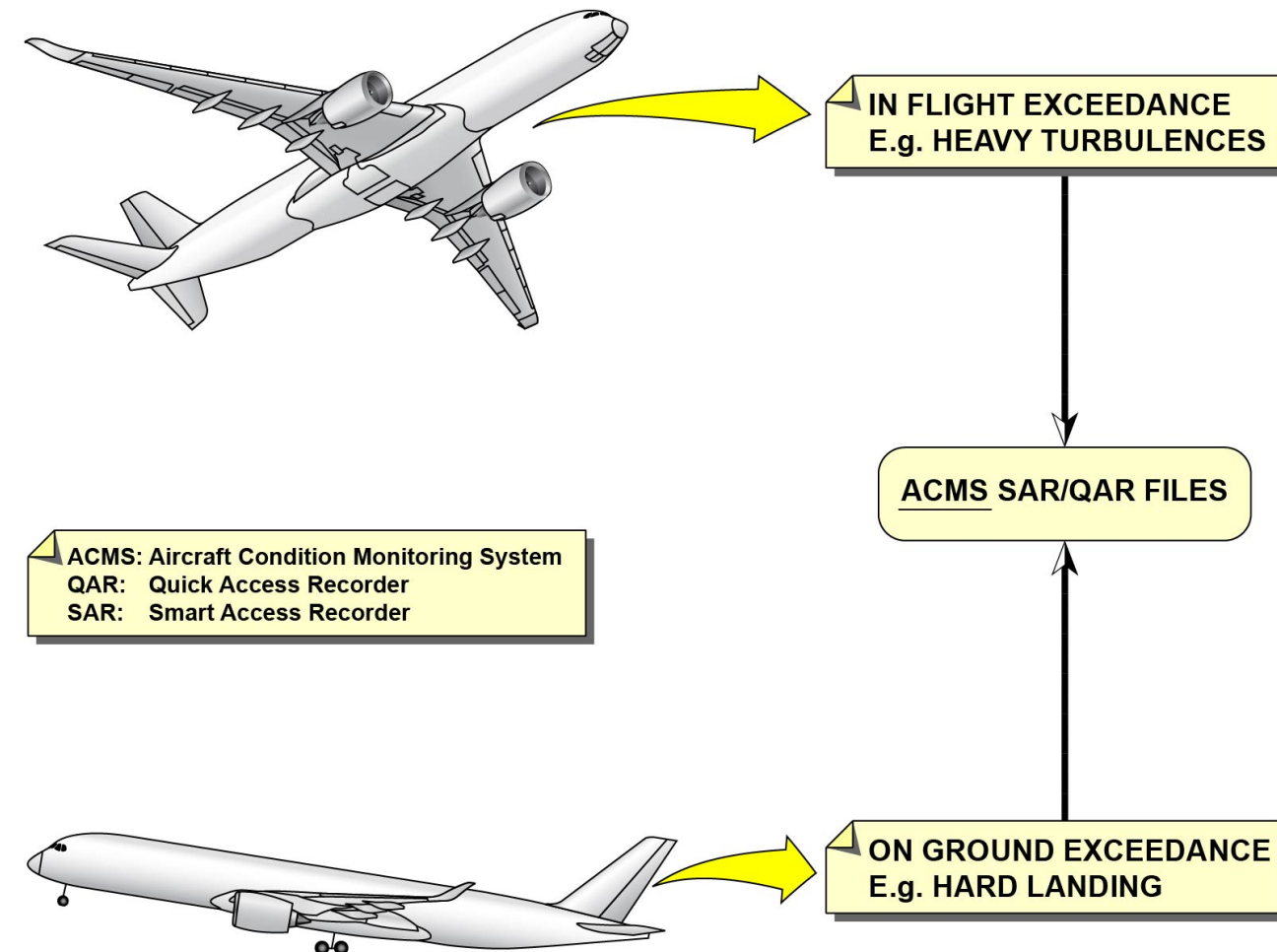
**EXCEEDANCE DETECTION**

LOAD EXCEEDANCE ANALYSIS SYSTEM DESCRIPTION (2)

ACMS SAR/QAR Files

The primary entry point for an exceedance assessment is the pilot report. The maintenance crew must get all the flight crew data to quantify and make an estimate of the conditions (Landing Gear (L/G), drag or side landing, asymmetrical landing).

On the ground, the usual process is to download the ACMS SAR/QAR files. When they are downloaded, the flight data parameters are used as inputs to calculate the different structural loads.

The load analysis tool will then recommend the AMM inspection tasks that are necessary.

If the SAR file or tool is not available, it is necessary to do the "standard" visual inspections (ATA 05-51-00).

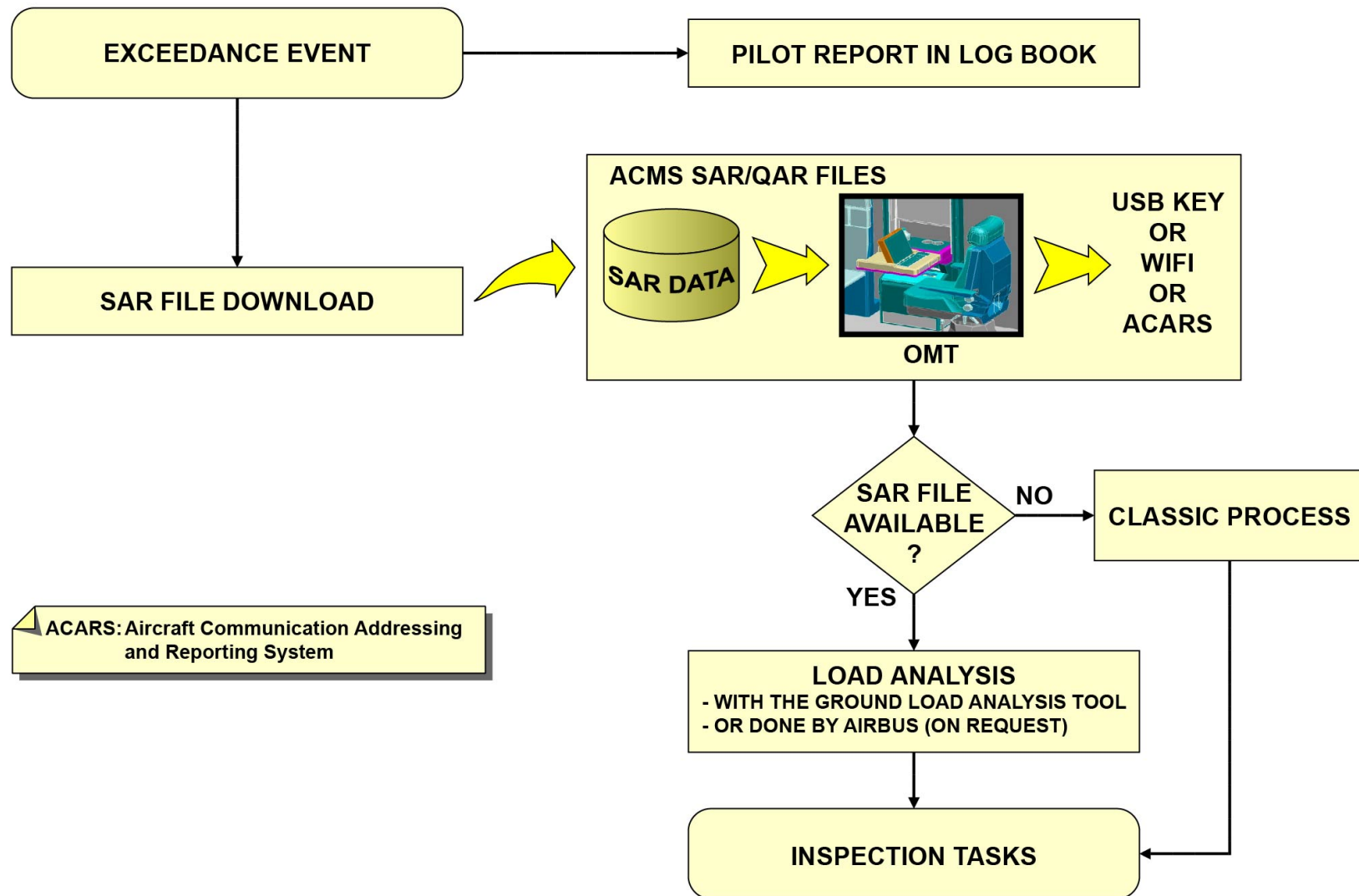

ACARS: Aircraft Communication Addressing and Reporting System

ACMS SAR/QAR FILES

V1813401 - V01T0M0 - VM32D2LEXMS2301

LOAD EXCEEDANCE ANALYSIS SYSTEM DESCRIPTION (2)

Load Analysis Tool

The load analysis tool gives an accurate indication of the inspections that are necessary.

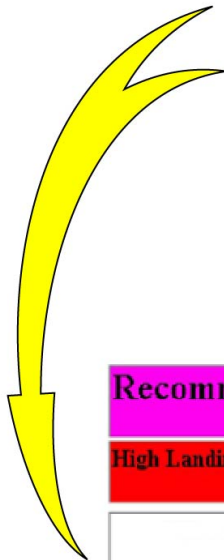
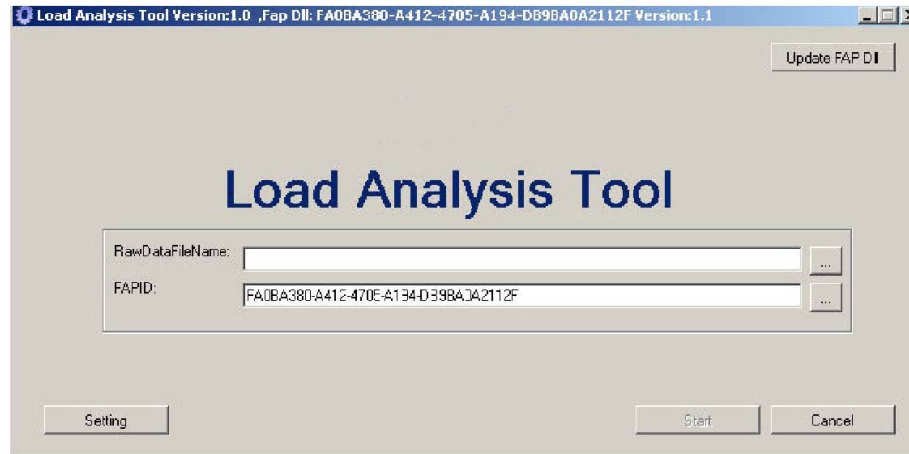

Recommended Inspection	
High Landing Loads: Perform Phase 1 Tasks	
	Chapter 05-51-11-210-00700
	Chapter 05-51-11-210-01700
	Chapter All LGs Inspection

EXAMPLES OF MAINTENANCE PROCEDURE TASKS

LOAD ANALYSIS TOOL

V1813401 - V01T0M0 - VM32D2LEXMS2301

LANDING GEAR NORMAL EXTENSION/RETRACTION SYSTEM DESCRIPTION (2/3)

Description

In normal conditions, the extension and retraction system uses the landing gear lever to extend and retract the landing gears. The system is electrically controlled and hydraulically operated. The sequence of operation is controlled by the Landing Gear Control and Indication System (LGCIS), which is divided into two redundant sides LGCIS 1 and 2, which operate independently.

Each side has two CPIOMs (Landing Gear Extension and Retraction System (LGERS) application), CRDCs and Solid State Power Controllers (SSPCs). Although the two sides are continuously supplied with electrical power, only one side controls the system at a time, while the other side continues the monitoring through the AFDX network.

A LGCIS side "in control" occurs at each time when:

- The landing-gear selector lever is selected to the UP position, or when
- The active side becomes unserviceable.

This decreases the risk of dormant failures.

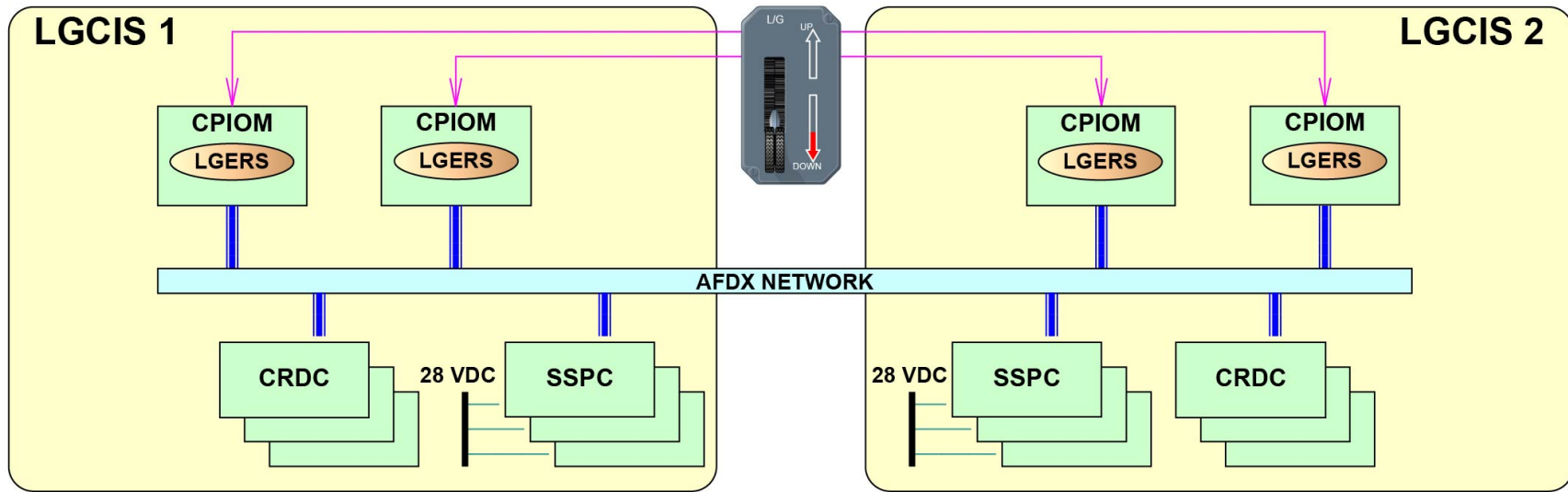

LGCIS: Landing Gear Control Indication System
LGERS: Landing Gear Extension and Retraction System
SSPC: Solid State Power Controller

DESCRIPTION

LANDING GEAR NORMAL EXTENSION/RETRACTION SYSTEM DESCRIPTION (2/3)

Description

The CPIOMs (LGERS application) control the Landing Gear (L/G) and door operations. For this function, solenoid operated valves are used to send the hydraulic supply to the related actuators. The valves are:

- The isolation valve
- The gear uplock valve
- The door uplock valve
- The gear selector valve
- The door selector valve.

The Yellow hydraulic system operates the Nose Landing Gear (NLG) and the Green hydraulic system operates the Main Landing Gear (MLG). The NLG and MLG sequences operate independently because they use different valves and actuators.

The CPIOMs contain the software to control all the valves. The power supply (28 VDC) from the SSPCs and the GROUND signals from the CRDCs are necessary for the valve to move to the commanded position. The SSPCs and CRDCs work in relation to the CPIOM commands orders through the AFDX network.

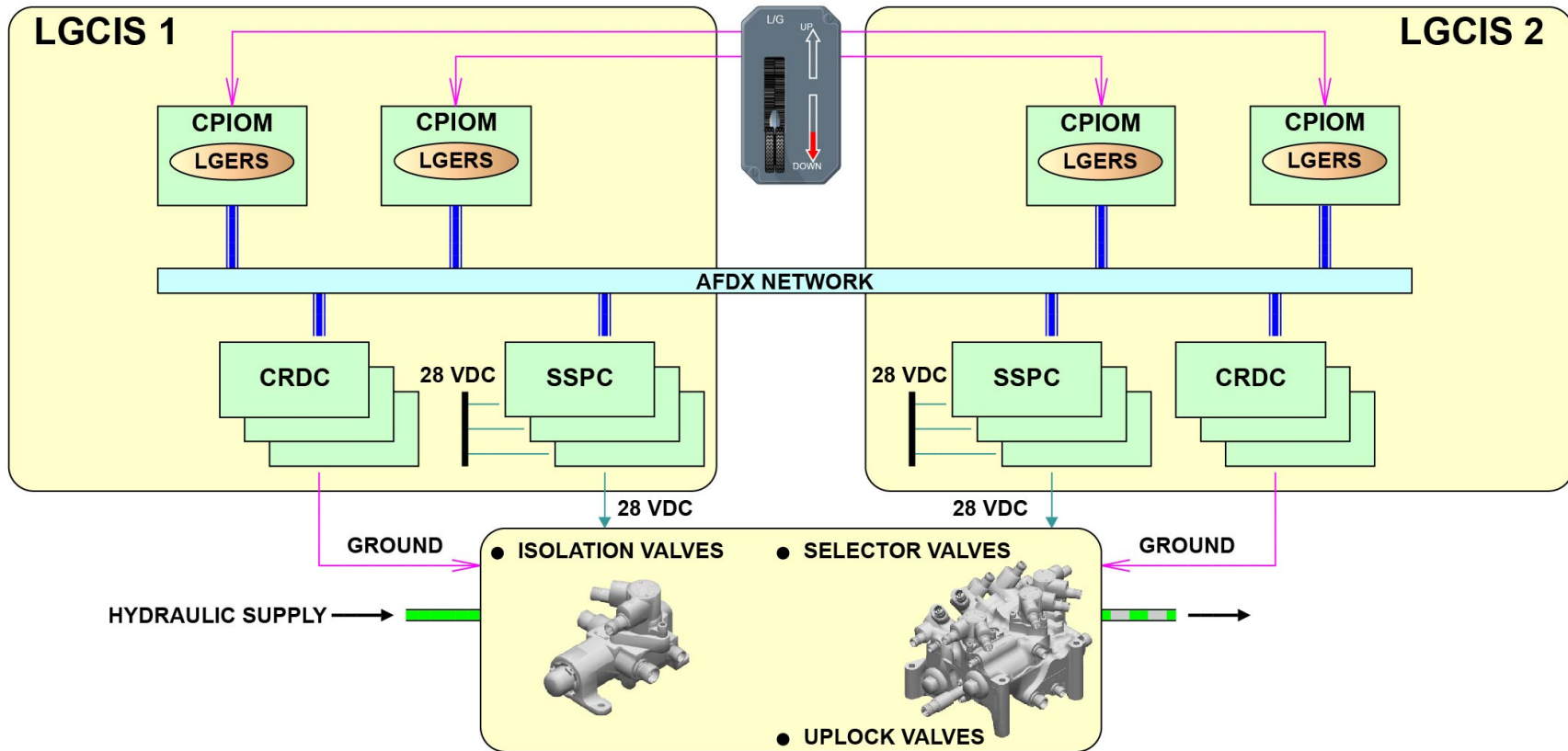

MLG: Main Landing Gear
NLG: Nose Landing Gear

MLG ONLY SHOWN.
SAME PRINCIPLE FOR NLG
WITH YELLOW SYSTEM.

DESCRIPTION

LANDING GEAR NORMAL EXTENSION/RETRACTION SYSTEM DESCRIPTION (2/3)**Description**

All the valves send the hydraulic supply to the related actuators in the correct time sequence.

The position and condition of the landing gears and doors are received and monitored by the CRDCs, from the proximity sensor signals. The signals are then sent to the CPIOMs through the AFDX network.

System 1 and System 2 use their own proximity sensors for redundancy purposes.

The landing-gear control lever has a baulk device that prevents the movement of the lever from the DOWN to the UP position when the aircraft is on the ground. The baulk can be removed by the energization of its operating solenoid through SSPCs controlled by the CPIOMs.

The Air Data/Inertial Reference System (ADIRS) sends aircraft speed signals to the CPIOMs to close the isolation valves at high speed (above 260 kts).

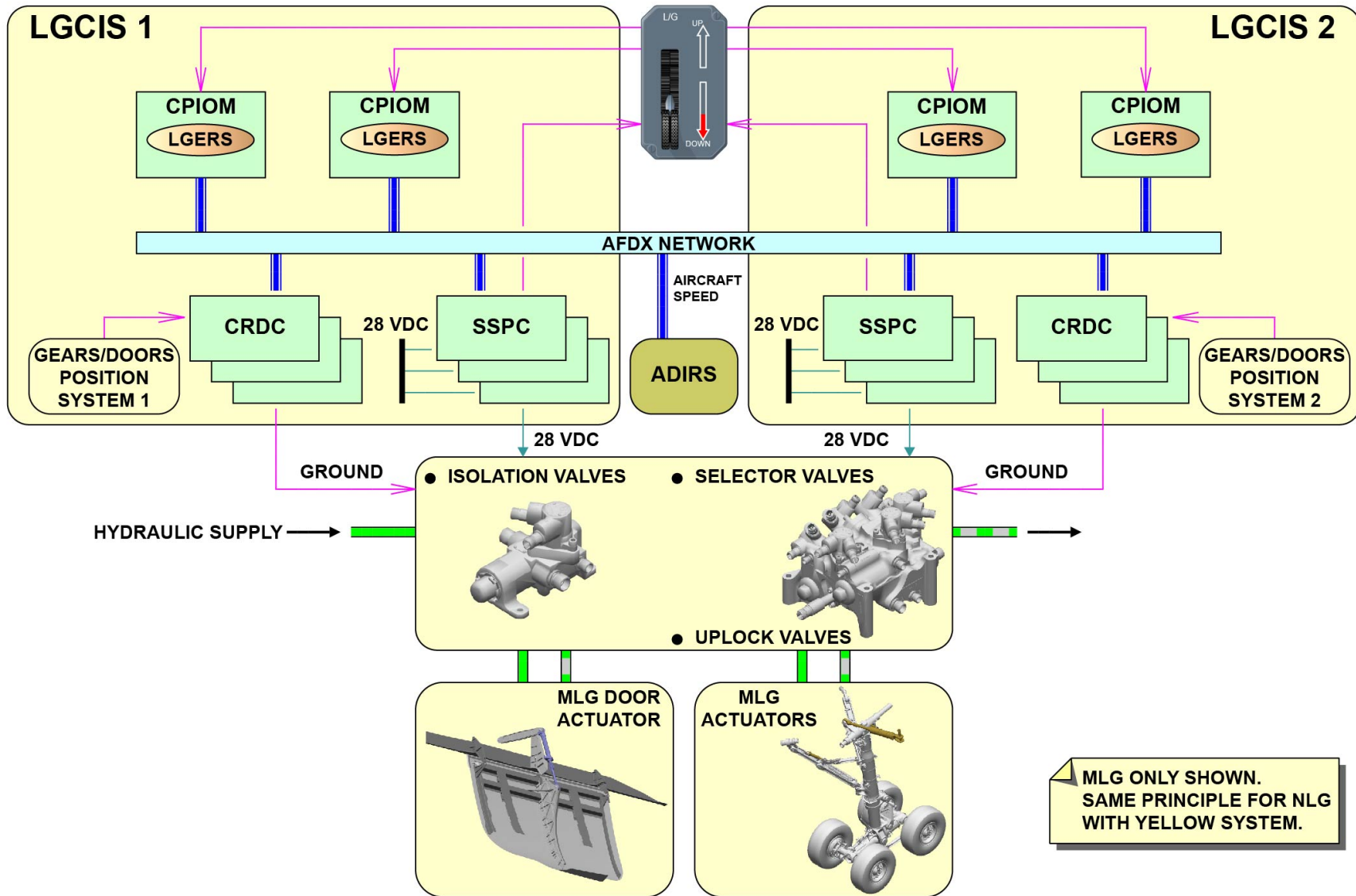

MLG ONLY SHOWN.
SAME PRINCIPLE FOR NLG
WITH YELLOW SYSTEM.

DESCRIPTION

V1813401 - V01T0M0 - VM32D3L GERS3001

LANDING GEAR NORMAL EXTENSION/RETRACTION SYSTEM DESCRIPTION (2/3)

Component Description

Two manifolds are used, one to control the equipment related to the NLG (uses the Yellow hydraulic supply) and the other to control the equipment related to the MLG (uses the Green hydraulic supply). Integrated manifold assemblies and related valves are used to control the normal system operation of the landing gears.

The isolation valves are used to make sure that pressurized hydraulic fluid is available to the normal LGERS. The LGCIS will make sure that the valve cannot be energized when the aircraft is in flight (more than 260 kts) and on the ground during take-off and landing.

The door sequence valves send hydraulic fluid to the open or the close side of the door actuators. Gear sequence valves send hydraulic fluid to the extend or retract side of the gear actuators.

The landing gears and doors have uplock units which lock the landing gears and doors in the retracted and closed position.

Each actuator supplies the mechanical force and displacement necessary to extend and retract the landing gears and doors during normal LGERS operation. All the landing gear actuators are of a double-acting linear hydraulic type.

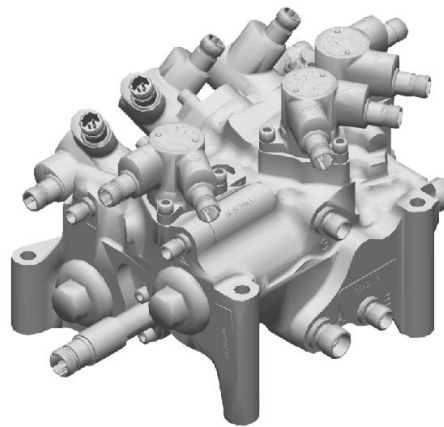
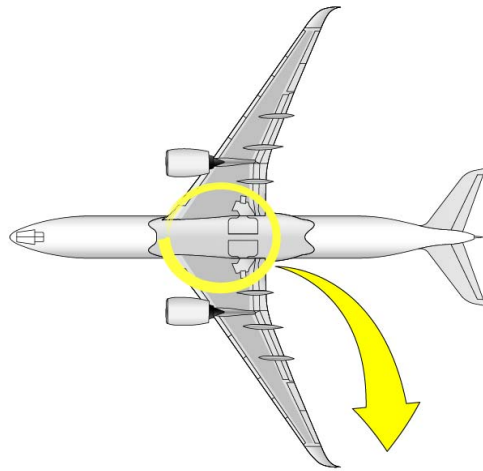

INTEGRATED MANIFOLD

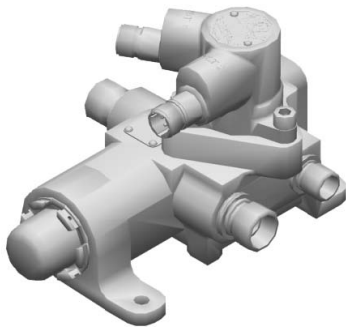
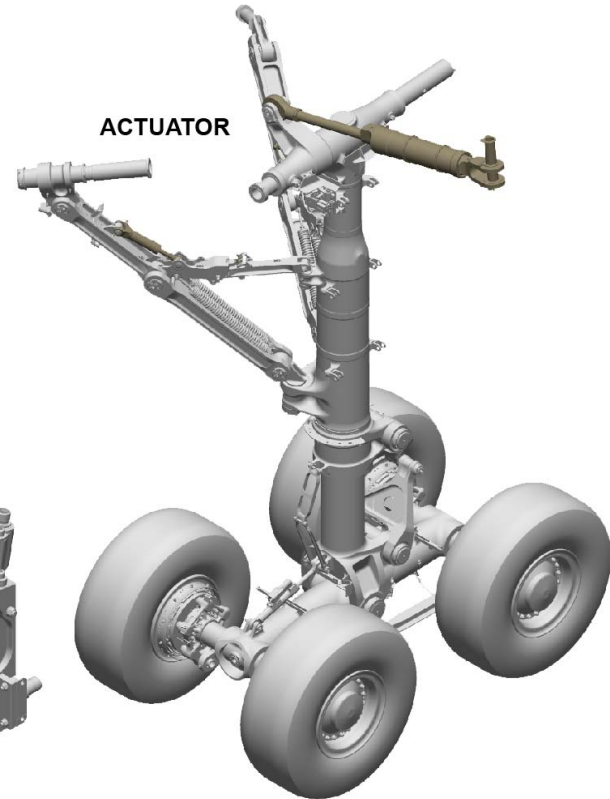

ISOLATION VALVE

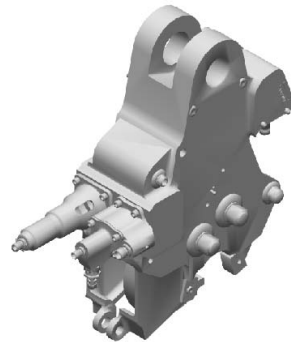

DOOR UPLOCK

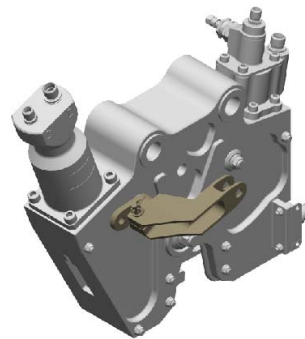

GEAR UPLOCK

ONLY MAIN LANDING GEAR SHOWN.

COMPONENT DESCRIPTION

V1813401 - V01T0M0 - VM32D3L GERS3001

LANDING GEAR NORMAL EXTENSION/RETRACTION SYSTEM DESCRIPTION (2/3)

Landing Gear Extension / Retraction

The example is given for the MLG, for the NLG the principle of operation is identical.

When the flight crew sets the landing gear lever to UP or DOWN, the active LGCIS generates and sends the applicable electrical commands in sequence to either retract and secure the L/G in the retracted and uplocked position or to extend and secure the L/G in the extended and downlocked position.

The initial conditions must be satisfied before the retraction sequence is started:

- The nose wheel steering is centered and the NLG shock absorber is fully extended.
- The left and right MLG shock absorbers are fully extended.
- The left and right MLG bogies are in the dip position.

When the flight crew sets the landing gear lever to UP for landing gear retraction:

- 1 The isolation solenoid valve is energized to open the hydraulic supply. A pressure transducer monitors the hydraulic pressure supply.
- 2 The door uplock solenoid-valve is energized to release the doors.
- 3 The door open selector-valve is energized to open the doors.
- 4 When the doors are fully opened, the gear retract solenoid-valve is energized to retract the landing gears.
- 5 When the landing gears are retracted and uplocked, the door close selector-valve is energized to close the doors.
- 6 When the doors are closed and uplocked, the isolation valve is de-energized and closed and the sequence is completed.

The initial conditions must be satisfied before the extension sequence is started:

- All doors are closed and uplocked.
- All gears are retracted and uplocked.

When the flight crew sets the landing gear lever to DOWN for landing gear extension:

- 1 The isolation solenoid valve is energized to open the hydraulic supply. A pressure transducer monitors the hydraulic pressure supply.
- 2 The door uplock solenoid valve is energized to release the doors.
- 3 The door open selector valve is energized to open the doors.
- 4 When the doors are fully opened, the gear extend solenoid valve is energized to extend the landing gears.
- 5 When the landing gears are fully extended and downlocked, the door close selector-valve is energized to close the doors.
- 6 When the doors are closed and uplocked, the isolation valve is de-energized closed and the sequence is completed.

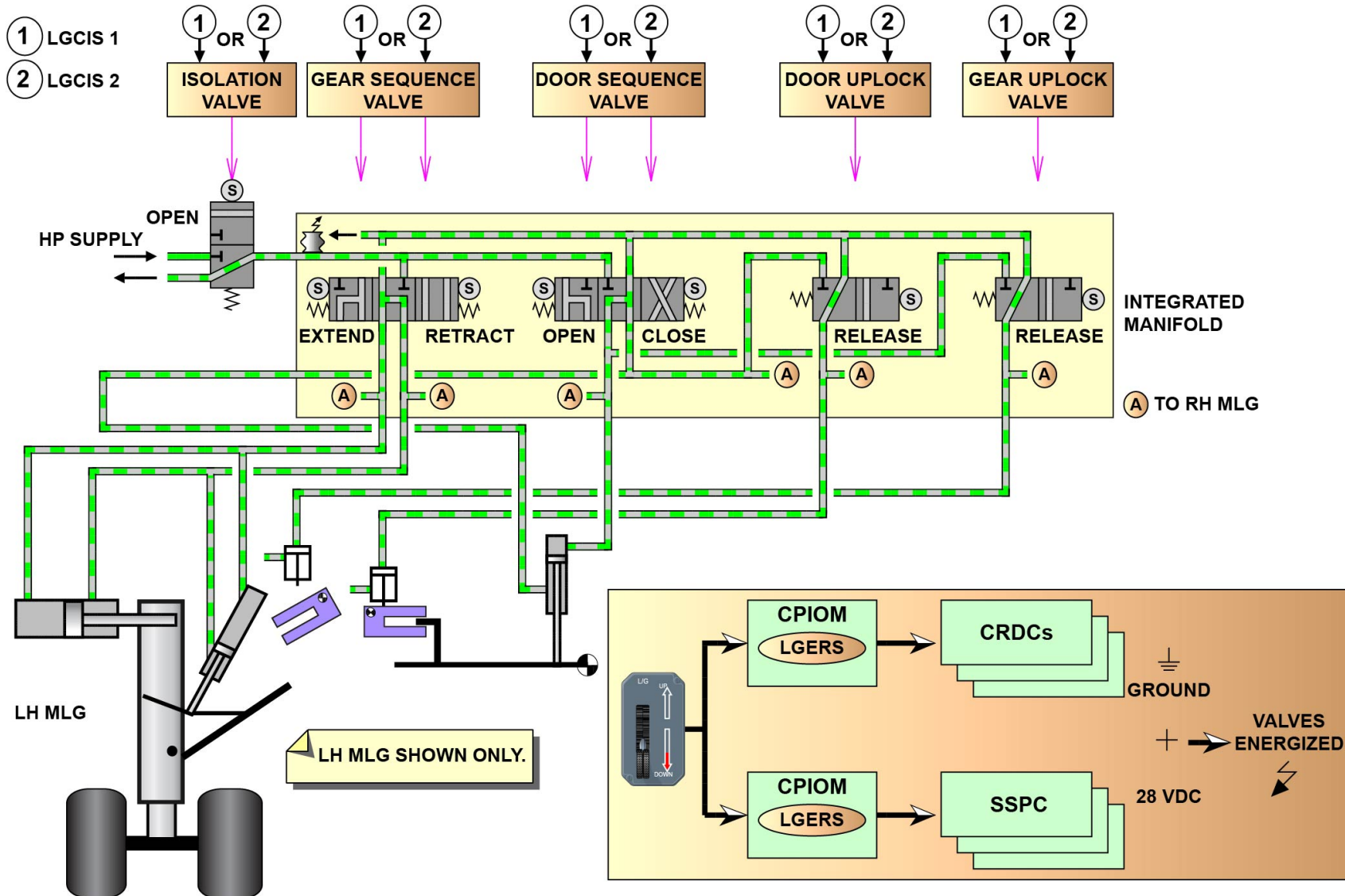

LANDING GEAR EXTENSION / RETRACTION

V1813401 - V01T0M0 - VM32D3L GERS3001

LANDING GEAR MONITORING SYSTEM DESCRIPTION (2/3)

Landing Gear Monitoring

The proximity sensors transmit data about the position of the gears and doors they are on:

- The Main Landing Gear (MLG) and the Nose Landing Gear (NLG) uplock and downlock
- The MLG and the NLG doors uplock and downlock
- The MLG shock absorber (extended)
- The MLG bogie (dip position)
- The NLG shock absorber (extended and centered)
- The MLG and NLG doors fully opened.

There are two sensors at each location, one for the Landing Gear Control Indication System (LGCIS) side 1 and one for the LGCIS side 2. There are two exceptions: the MLG bogie beam position and the down-lock sensors which operate independently. There are four sensors to send the data for the bogie beam position. They measure the movement between the target on the bogie beam and the sensor on the sliding tube. There are two sensors for each channel and each sensor monitors the movement in one direction. The downlock sensors of the NLG and the MLGs operate independently for the LGCIS side 1 and the LGCIS side 2.

NLG DOWNLOCK SENSOR

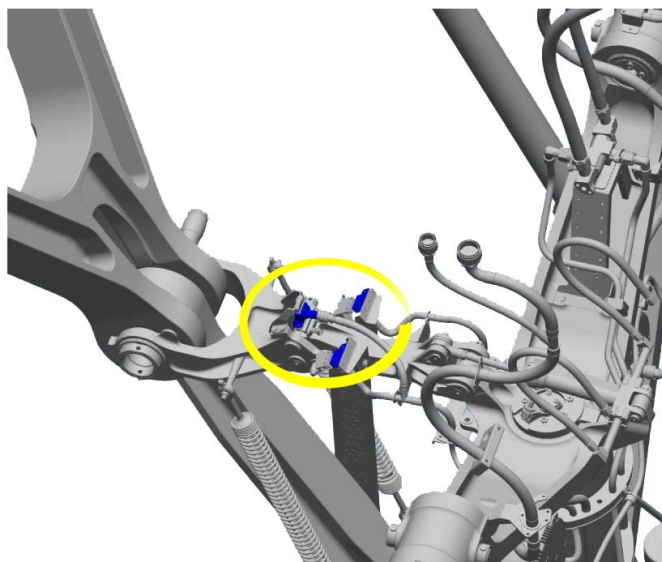

NLG: Nose Landing Gear

NLG EXTENDED AND CENTERED SENSOR

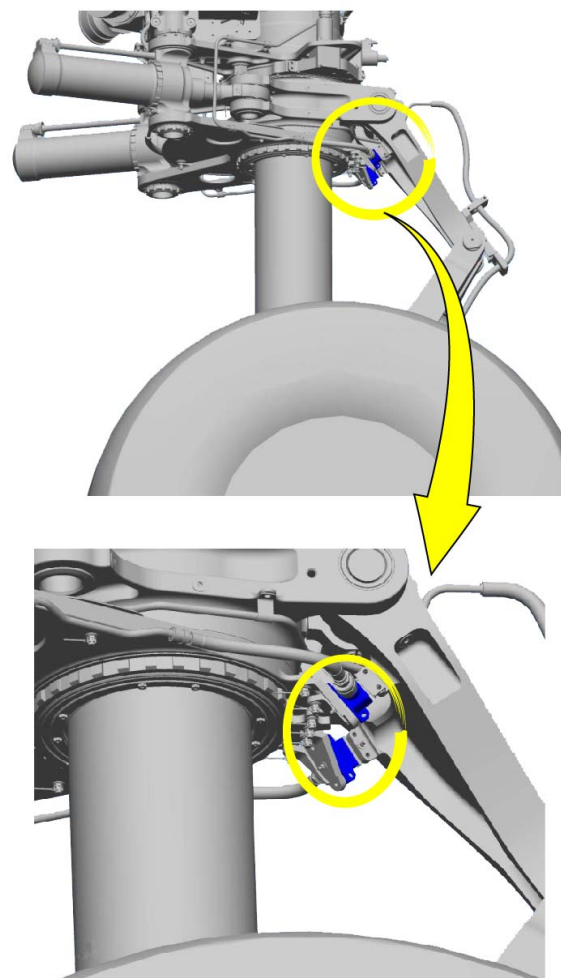

LANDING GEAR MONITORING

MLG DOWNLOCK SENSOR

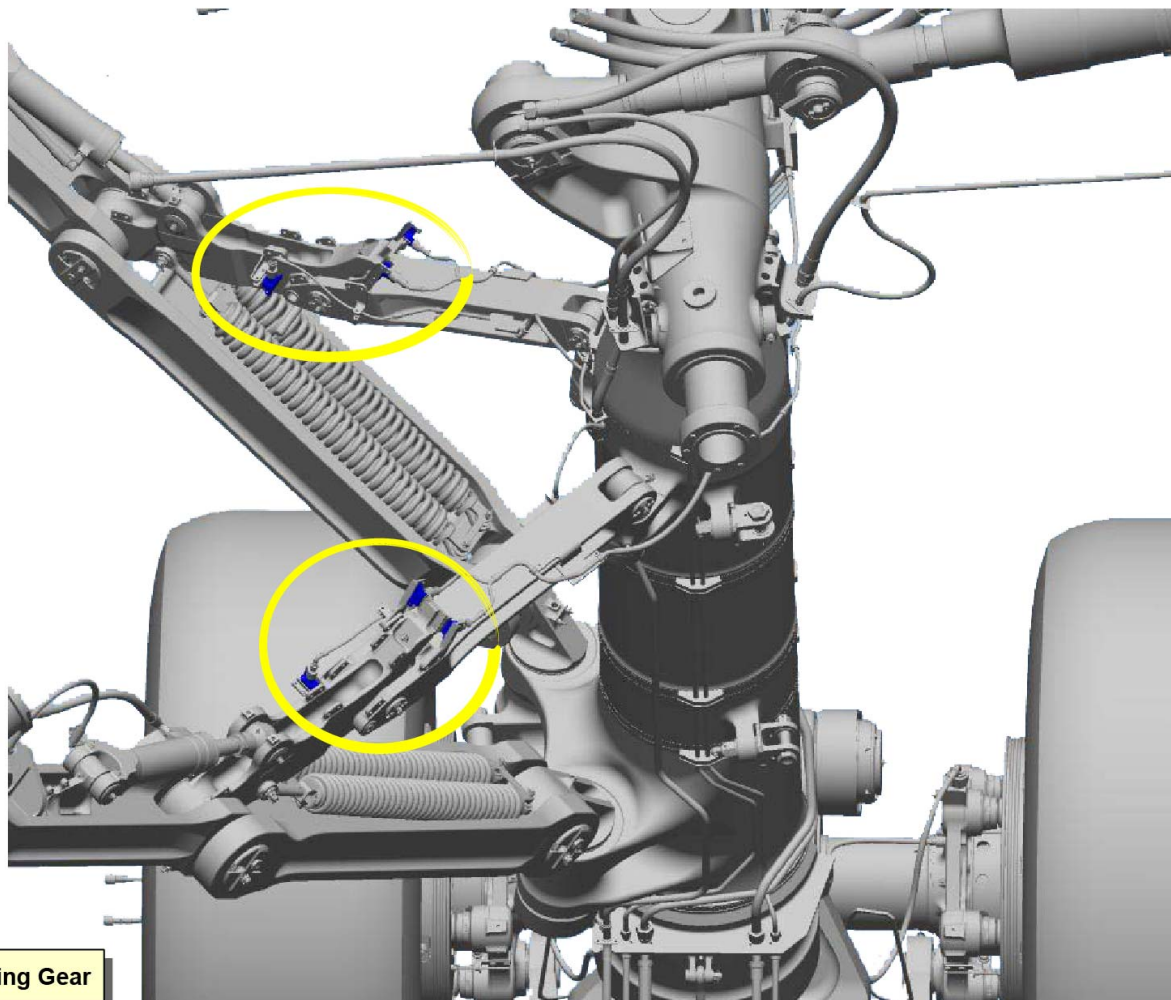

MLG: Main Landing Gear

LANDING GEAR MONITORING

V1813401 - V01T0M0 - VM32D4MONIT3001

BOGIE DIP SENSOR

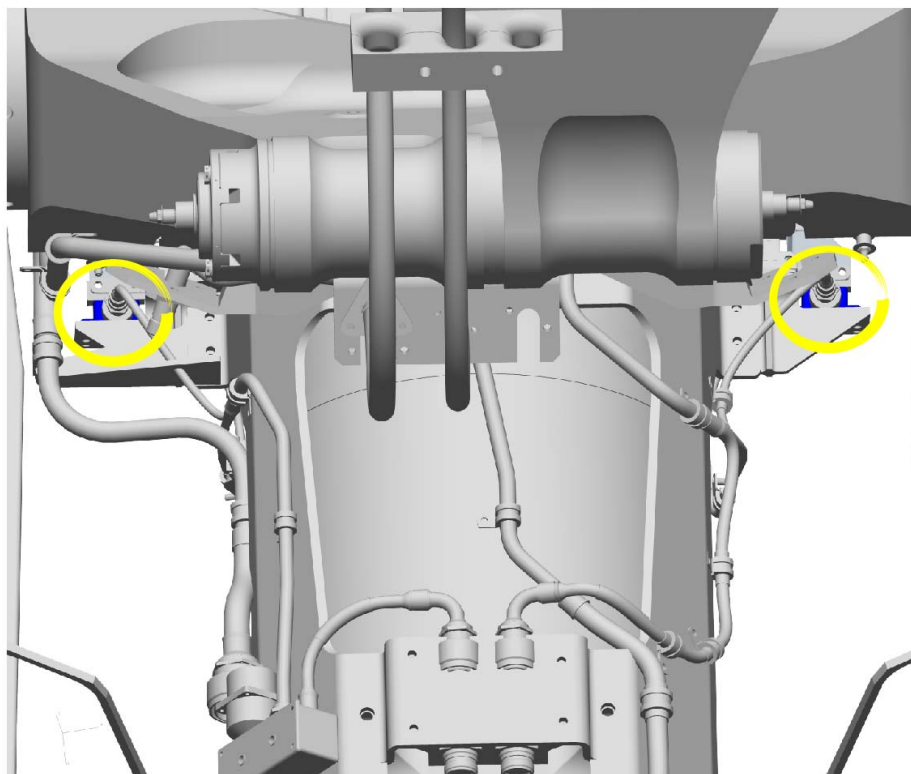

MLG EXTENDED SENSOR

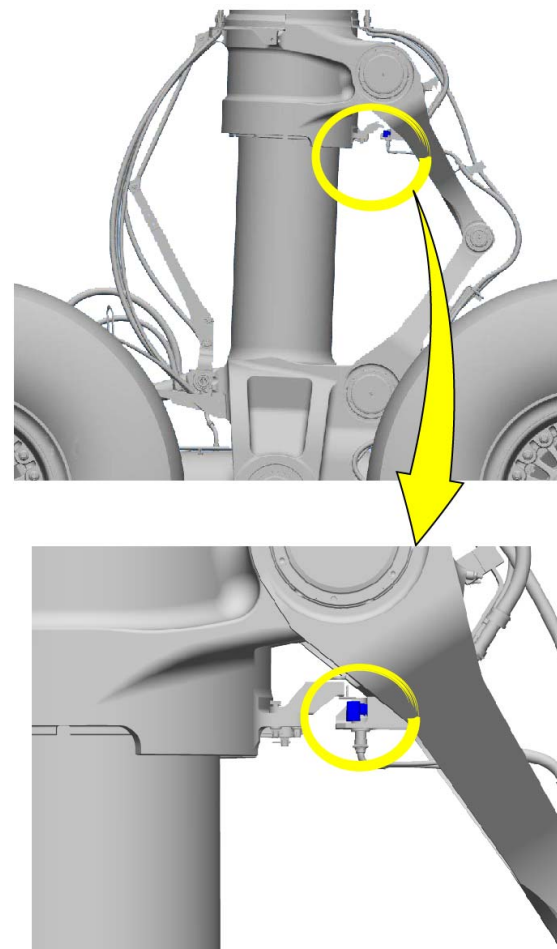

LANDING GEAR MONITORING

V1813401 - V01T0M0 - VM32D4MONIT3001

DOOR PROXIMITY SENSOR

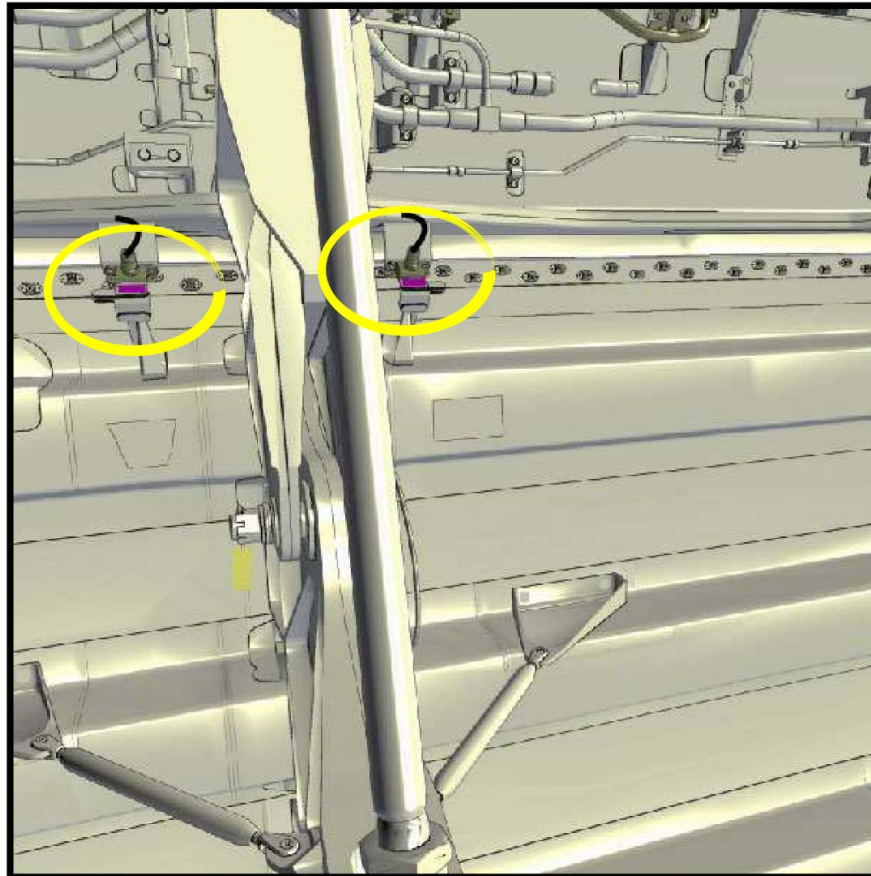

LANDING GEAR MONITORING

V1813401 - V01T0M0 - VM32D4MONIT3001

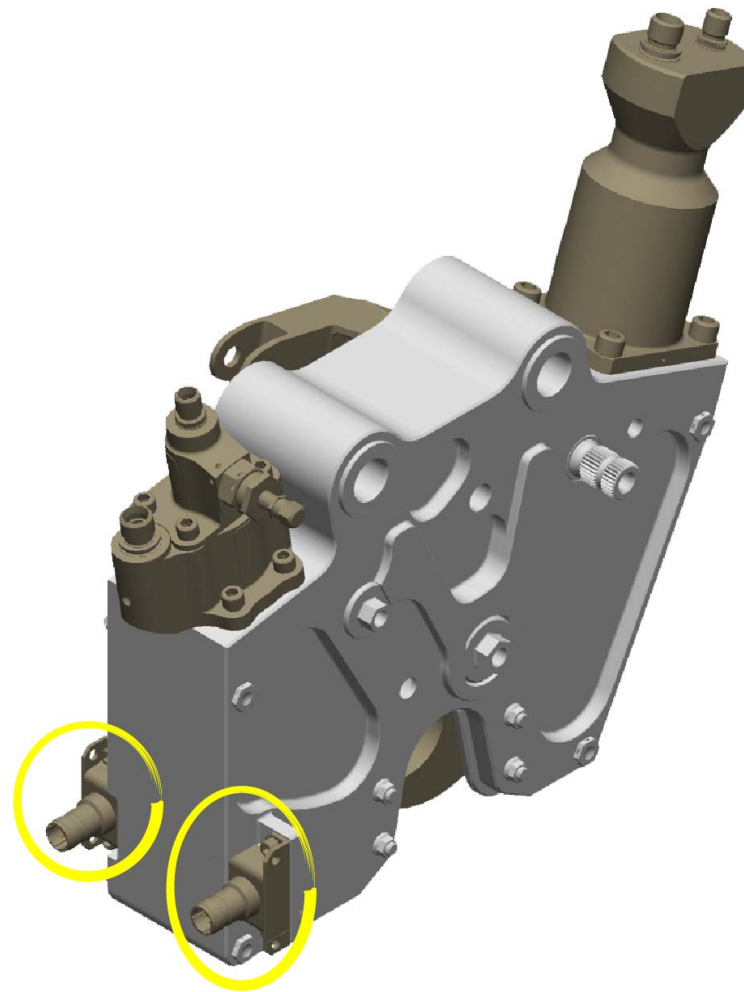

UPLOCK ASSY PROXIMITY SENSOR

LANDING GEAR MONITORING

V1813401 - V01T0M0 - VM32D4MONIT3001

LANDING GEAR MONITORING SYSTEM DESCRIPTION (2/3)

Proximity Sensor

The landing gear system uses two different displays to show the landing-gear system status:

- The system-display wheel page
- Slat-flap limitation memo below the PFD.

Proximity sensors are used to show the landing gear sequences and interface for the other systems. Each proximity sensor sends data to the CRDCs. From the CRDCs, the data are sent to the aircraft systems (mainly for air/ground information) and for the cockpit indication.

The gear downlock-position data shown in the cockpit is calculated by a consolidated "AND" logic from the LGCIS 1, the LGCIS 2 and the independent sensors data. A minimum of two sources are necessary for each gear to confirm a "downlocked" position.

The Landing Gear Extension and Retraction System (LGERS) sends Weight on Wheels (WoW) data to the other aircraft systems to show that the aircraft is in flight or on the ground. To calculate if the weight is on wheels for each gear, the CRDC does an "AND" logic of the output from two proximity sensors: one shows that the gear is downlocked and one shows that the shock strut is not fully extended, As a result, there is a "GEAR ON GROUND" signal from each of the CRDCs.

All the data from the LGCIS 1 and 2 are added together to get a valid OR (one for system 1 and one for system 2) WoW logic.

From the system CRDCs which operate independently, the L/G downlock status is also sent to the CDS (hard-wired and through the Flight Warning System (FWS)).

IND SYSTEM

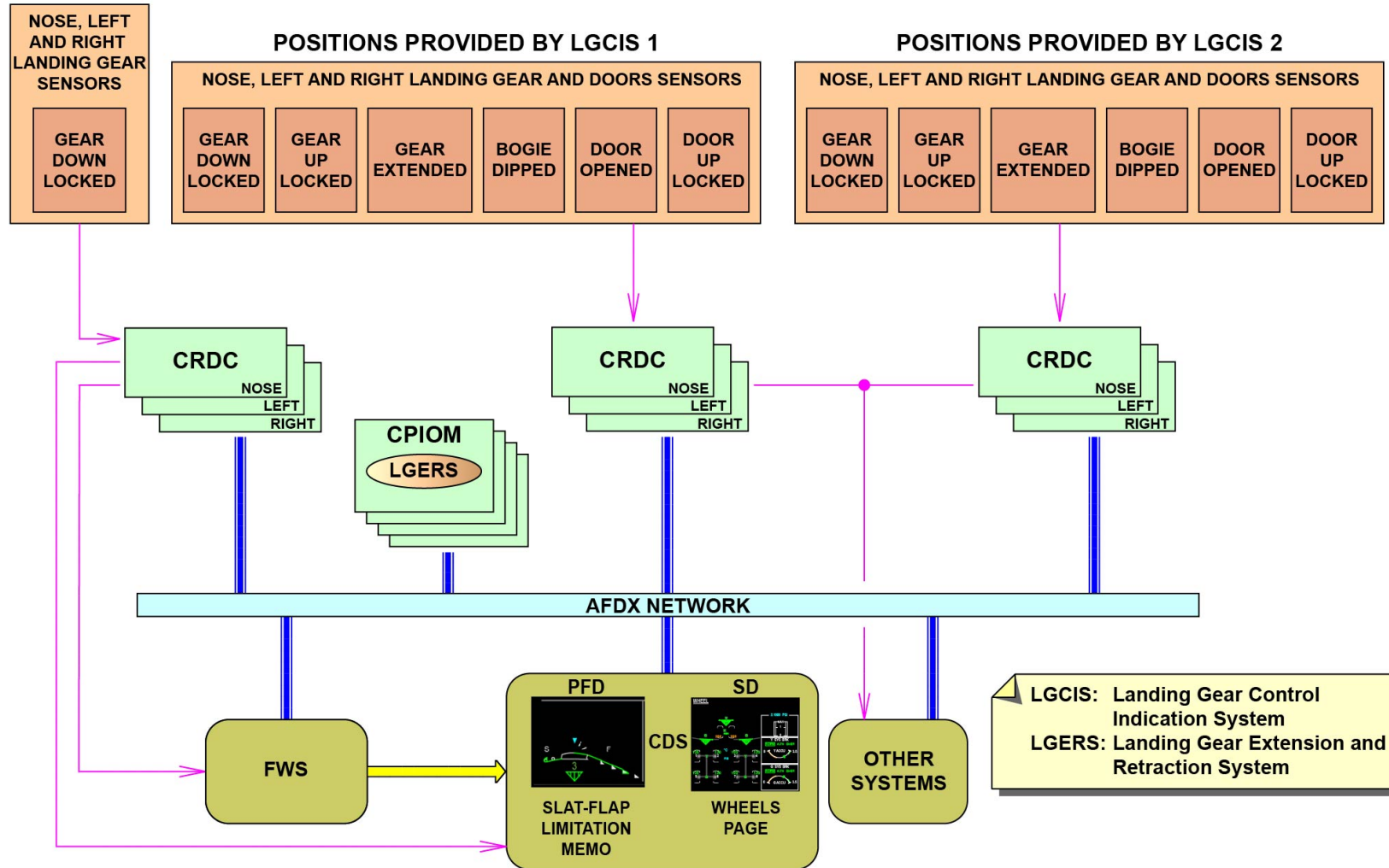

PROXIMITY SENSOR

V1813401 - V01T0M0 - VM32D4MONIT3001

LANDING GEAR MONITORING SYSTEM DESCRIPTION (2/3)

Proximity Sensor Adjustment

For the maintenance procedures, there must be a gap between the sensor and the target. The sensor can be adjusted with bolts and nuts on the target or on the sensor. You can use the shims to get the necessary gap. You can use the shims, calipers or the OMT specific menu to measure the gap.

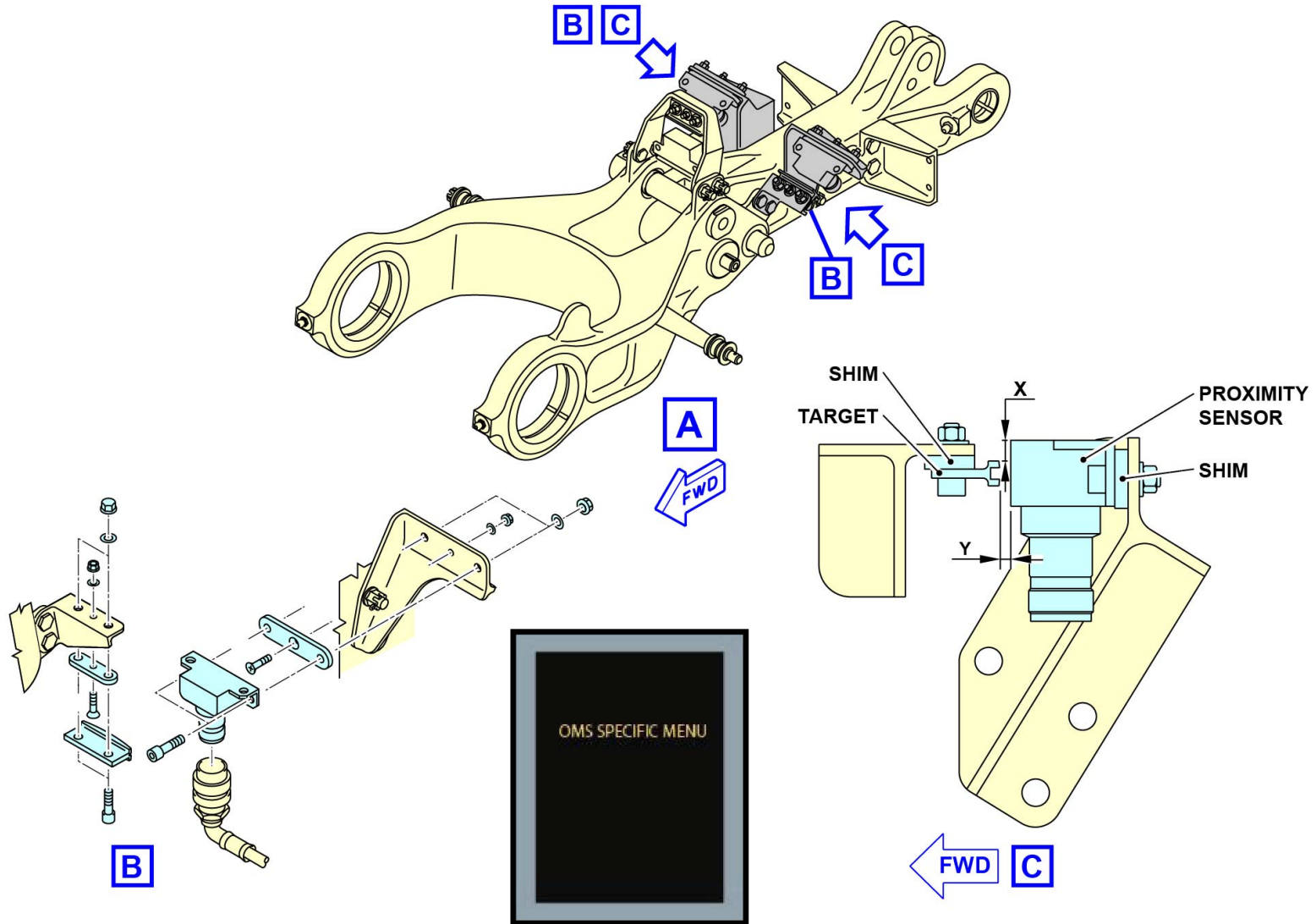

PROXIMITY SENSOR ADJUSTMENT

V1813401 - V01T0M0 - VM32D4MONIT3001

GROUND DOOR OPENING SYSTEM DESCRIPTION (2)

Landing Gear Ground Door Opening

The Ground Door Opening (GDO) system can be operated on the ground from outside the aircraft to get access to the landing gear bays for maintenance. There is a system for the Nose Landing Gear (NLG), the left Main Landing Gear (MLG) and the right MLG. The GDO handles have two stable positions: open or closed. For safety purposes, the position of the GDO handles is such that the operator is not in the range of travel of the landing gear doors. A safety pin on the MLG GDO handles locks the lever in the open or closed position. In the MLG GDO, two steps are necessary to release the handle with latch release device. In the NLG GDO, two steps are necessary to release the handle with release buttons.

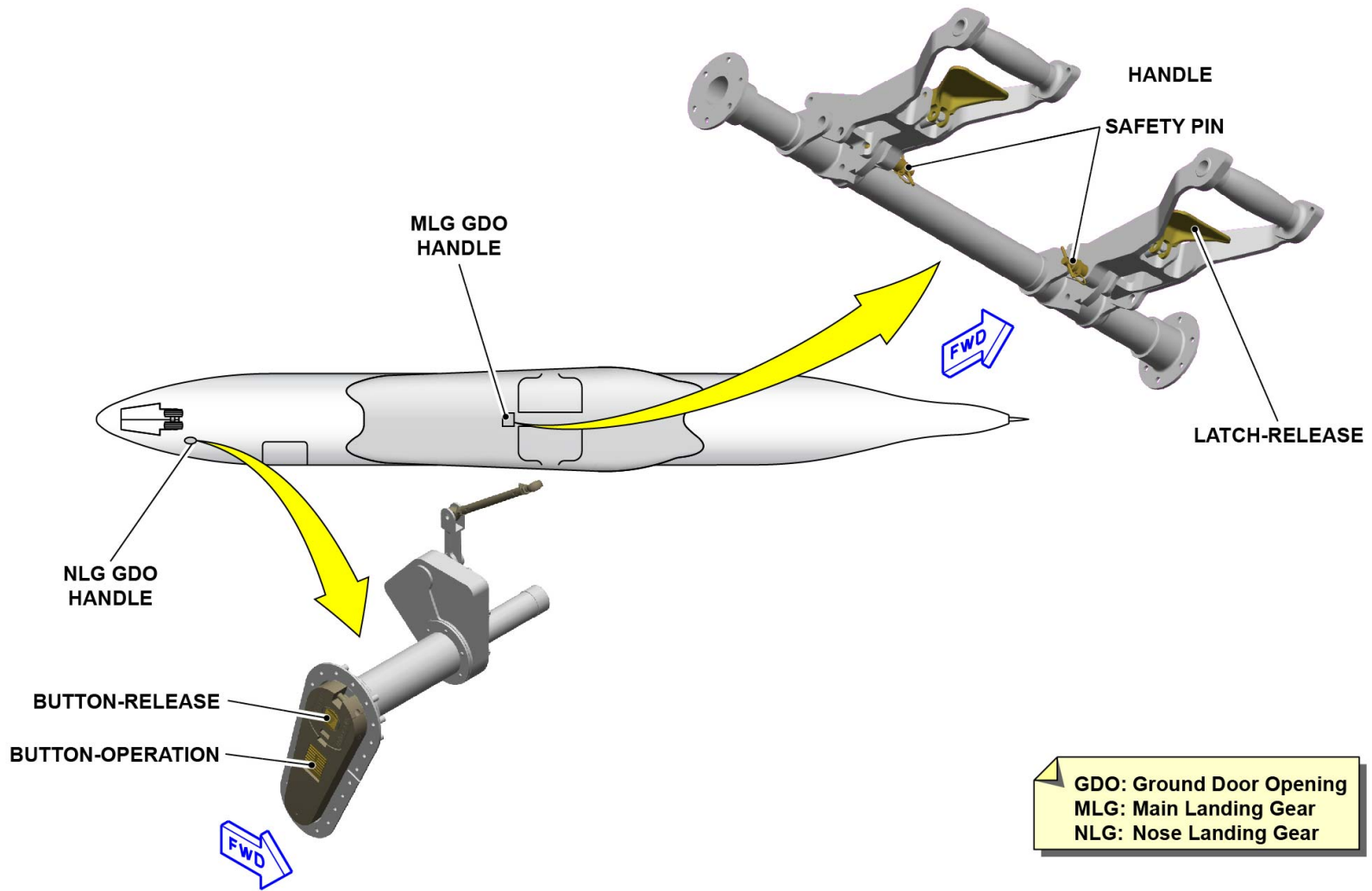

GDO: Ground Door Opening
 MLG: Main Landing Gear
 NLG: Nose Landing Gear

LANDING GEAR GROUND DOOR OPENING

V1813401 - V01T0M0 - VM32D5GDONM2301

GROUND DOOR OPENING SYSTEM DESCRIPTION (2)

Ground Door Opening Hydraulic System

Each ground door-opening handle operates a bypass valve and a door uplock.

Each handle is connected by a mechanical linkage to a door bypass valve, which moves to a bypass position. The function of the valve is to isolate the door actuators from the hydraulic supply line and to connect the two actuator chambers, to let the free fluid circulation. The handle is also connected to the door uplock assembly which rotates the hook to release the door. The door will open freely by gravity.

A mechanical fuse pin gives the GDO system protection from damage, if a mechanic applies too much force to one of the GDO handles.

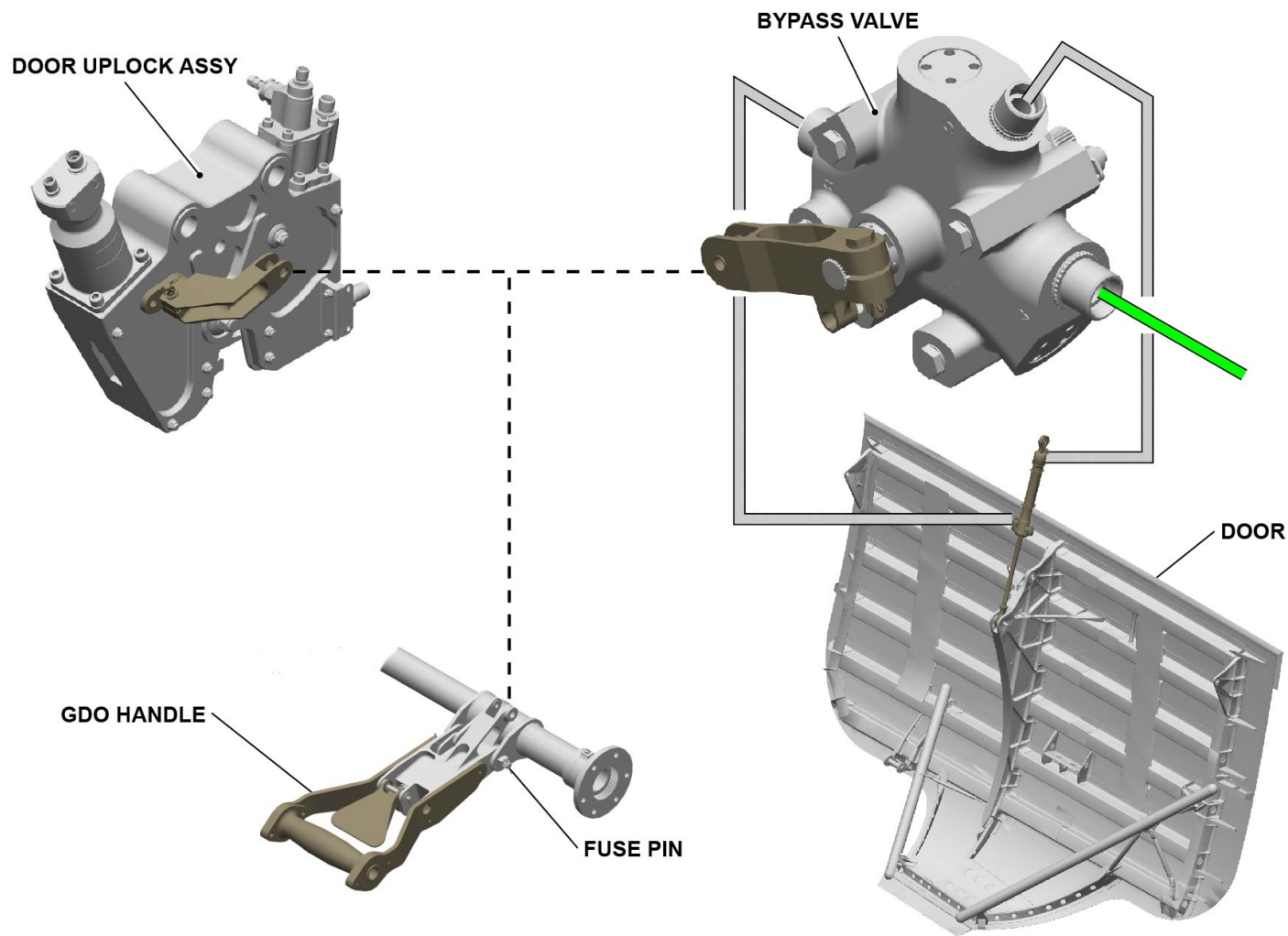

GROUND DOOR OPENING HYDRAULIC SYSTEM

V1813401 - V01T0M0 - VM32D5GDONM2301

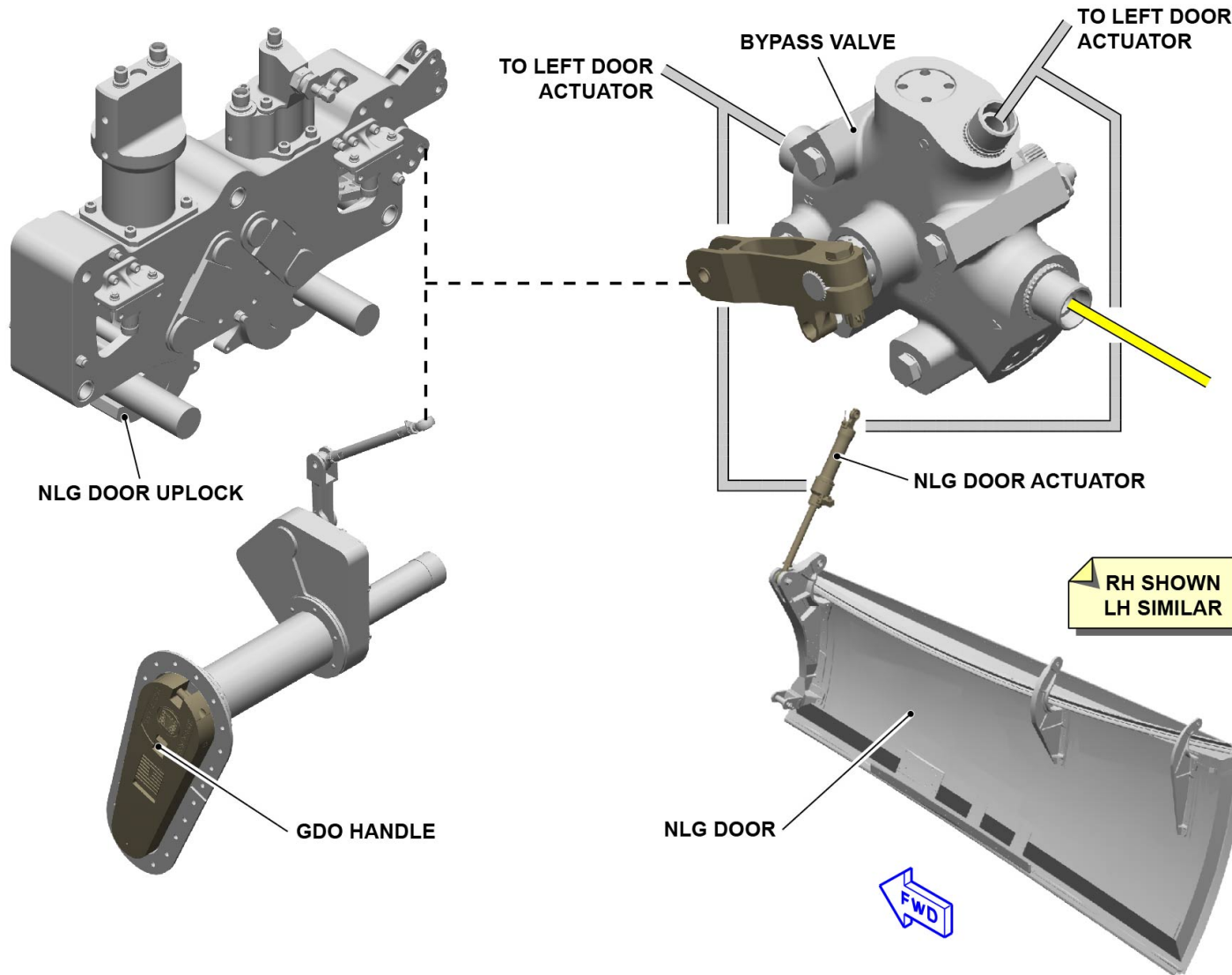

GROUND DOOR OPENING HYDRAULIC SYSTEM

V1813401 - V01T0M0 - VM32D5GDONM2301

This Page Intentionally Left Blank

GROUND DOOR OPENING SYSTEM DESCRIPTION (2)

Ground Door Opening Hydraulic System

When the aircraft is on the ground, the usual configuration is:

- Landing-gear selector lever in the down position
- All gears downlocked, with the hydraulically-controlled doors closed and uplocked
- Bypass valve open with no effect L/G door system operation.

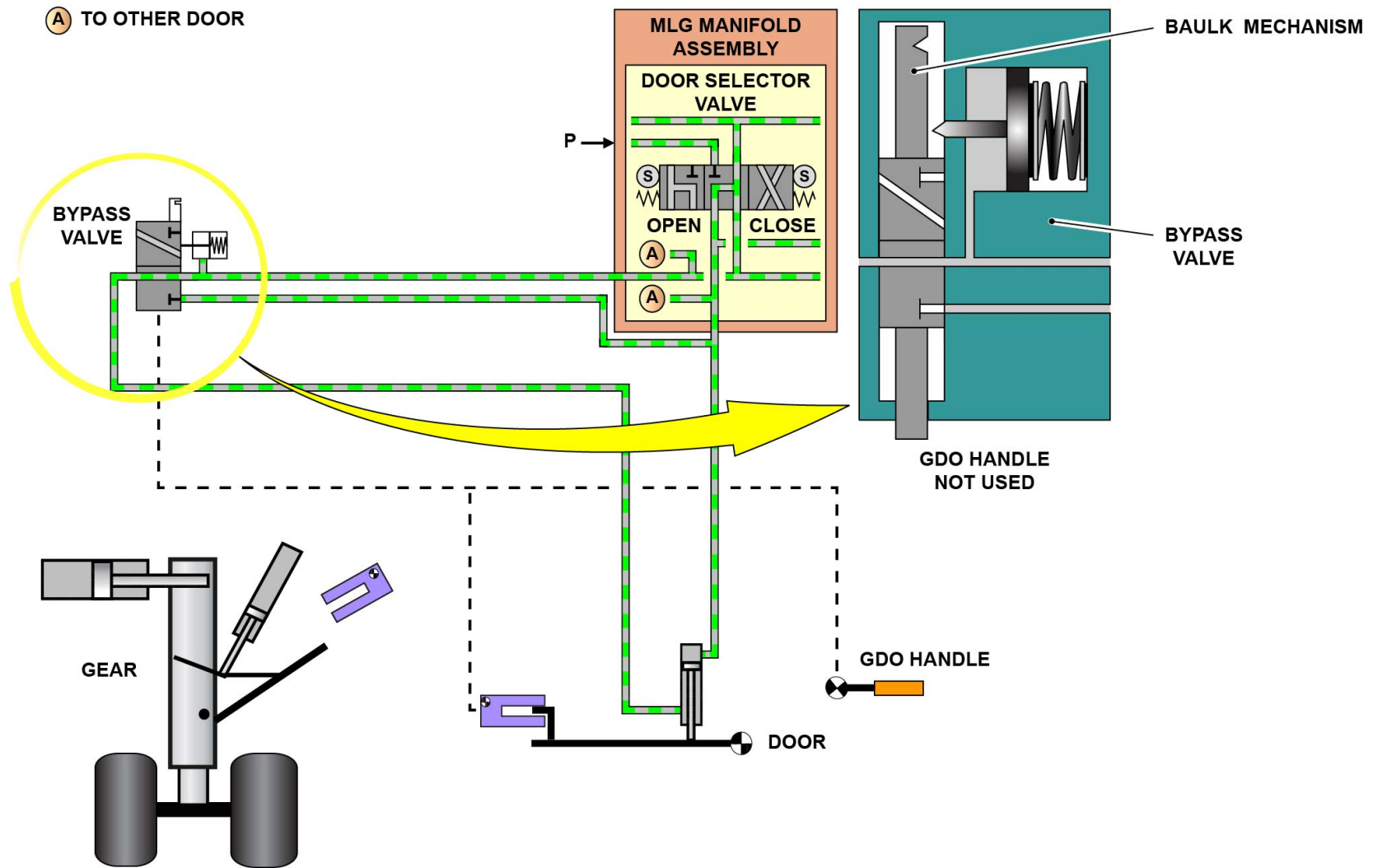

GROUND DOOR OPENING HYDRAULIC SYSTEM

V1813401 - V01T0M0 - VM32D5GDONM2301

GROUND DOOR OPENING SYSTEM DESCRIPTION (2)

Ground Door Opening Hydraulic System

When the GDO handle is moved to the open position, it isolates the door close line from the hydraulic supply and the door selector valve. It is thus not possible for the normal system to close the door.

NOTE: It is necessary to install door actuator collars each time the doors are open.

To give protection from accidental operation of the GDO system, the bypass valve includes a baulk mechanism. This will not let the GDO handle move to the closed position unless the electrical and hydraulic power are on.

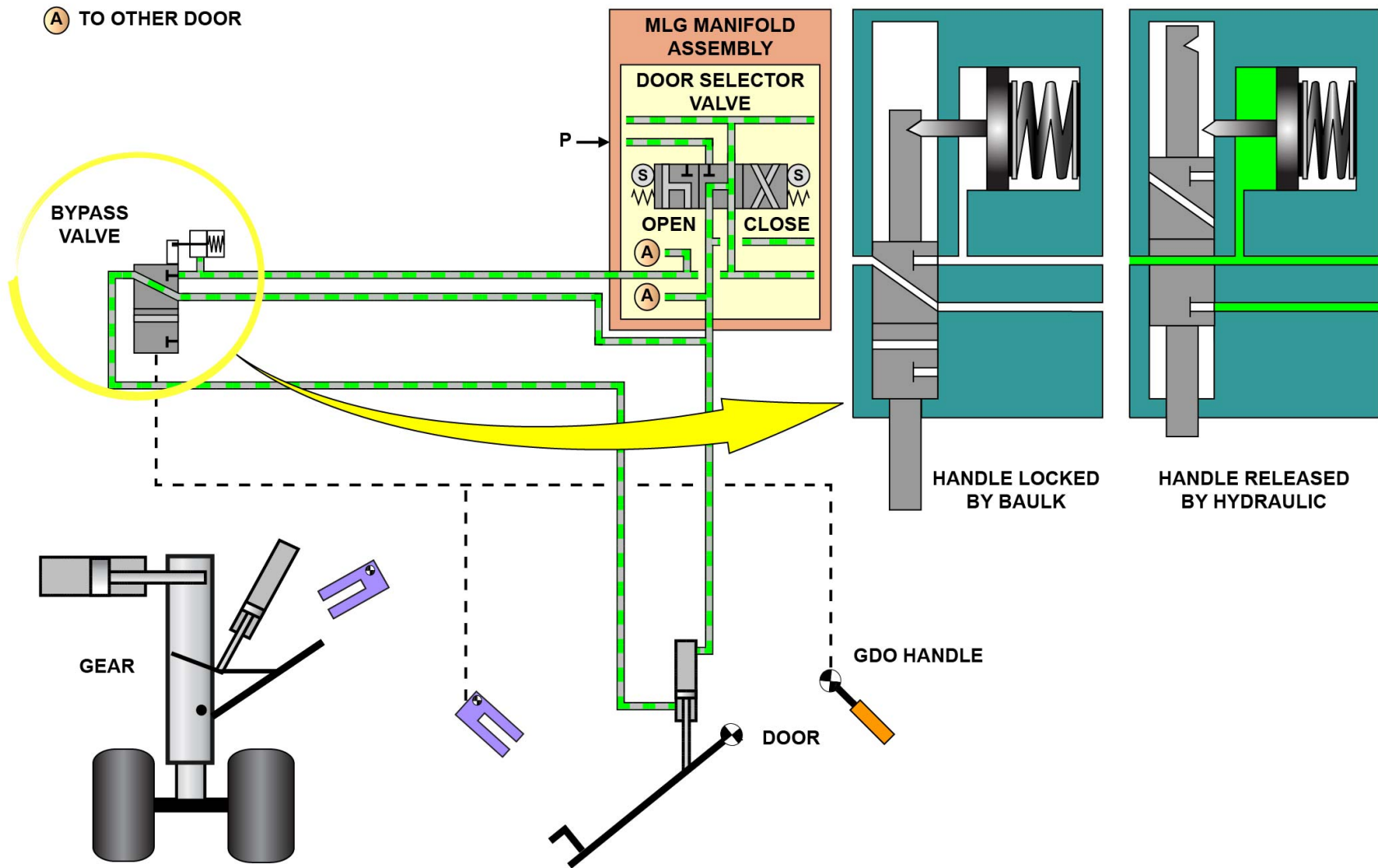

GROUND DOOR OPENING HYDRAULIC SYSTEM

V1813401 - V01T0M0 - VM32D5GDONM2301

LANDING GEAR ALTERNATE EXTENSION SYSTEM DESCRIPTION (3)

Alternate Extension Principle

If an electrical or hydraulic failure of the normal extension system occurs, the alternate extension system releases the gear and door uplocks as an alternative and independent method of extension.

The alternate extension system operates independently of the AFDX network. Because of this, failures in normal control mode have no effect on the alternate mode.

The alternate extension system operates independently after it receives a down command signal from the L/G GRAVITY EXTENSION control panel.

Two Alternate Extension Control Modules (AECM), A and B, are used to control and energize the electrical power to the alternate power pack for extension and reset sequences. There is one alternate power pack for the Nose Landing Gear (NLG) and one for the two Main Landing Gears (MLGs).

The alternate extension system isolates the Landing Gear Extension and Retraction System (LGERS) hydraulic circuit from the normal hydraulic supply. It also uses vent valves to reconfigure the circuit. To prevent hydraulic locks, the vent valves let hydraulic fluid circulation inside the actuators and connect all the actuator chambers to a return.

The hydraulic system has:

- Two alternate power packs which supply the hydraulic pressure to operate the vent valves and then release the door and gear uplocks
- Two vent valves (one for the MLG, one for the NLG), which connect all the actuator chambers together and to the return circuit
- Gears and doors uplock assembly.

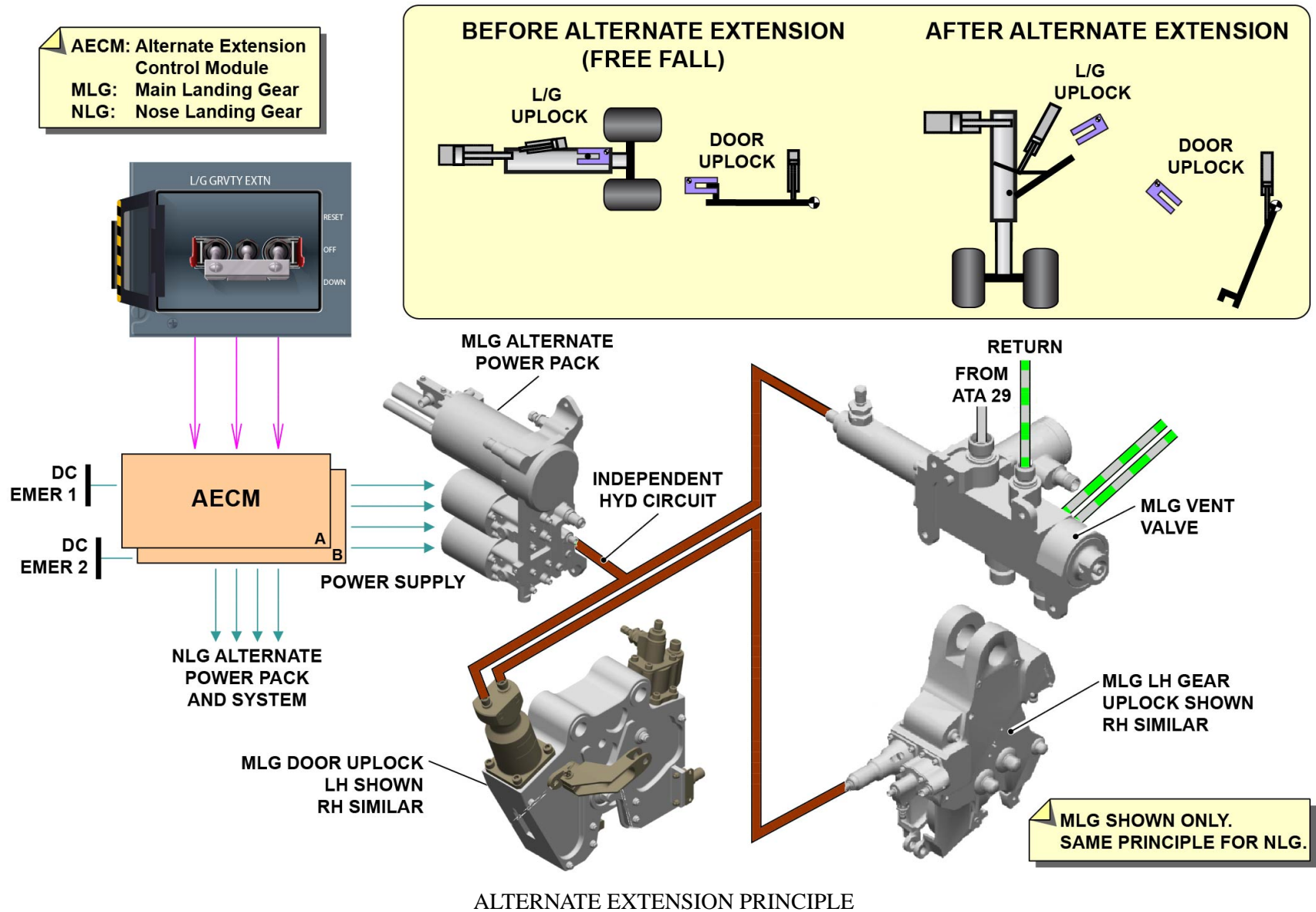

V1813401 - V01T0M0 - VM32D6FFALL.3001

LANDING GEAR ALTERNATE EXTENSION SYSTEM DESCRIPTION (3)

Hydraulic Components Description

The alternate power packs are used to change electrical input power into hydraulic output power to operate the alternate system (vent valve operation and door and gear uplock release). There are two alternate power packs, one for the NLG alternate extension equipment and one for the MLG alternate extension equipment.

A visual quantity indicator is used to monitor the alternate power pack reservoir periodically.

A fill and bleed valve is installed on the alternate power pack for circuit refilling.

The vent valves are used to make sure that the door actuators and gear actuators are connected in a hydraulic bypass and to the return circuit. This is to make sure that no hydraulic locks can occur and prevent extension. Two vent valves are used in the system, one to vent the NLG related actuators and one to vent the MLG related actuators. When operated by the alternate extension system, the vent valves are internally held in the vent position through a spring-loaded detent mechanism. This mechanism is released through an unlock solenoid which is energized during the alternate system reset.

A visual pop-out indicator is only out in the "venting" position.

A fill/bleed valve is installed on the vent valve for circuit refilling.

The gear and doors uplock assembly contains a latching/hook mechanism to uplock the gears and doors in the closed position. When the hydraulic circuit is pressurized, the hook turns and the uplock assembly is in the released position. Each gear and door uplock assembly has dedicated ports connected to the hydraulic circuits (one for the normal HP and one for the alternate extension).

A fill/bleed valve is installed on the uplock assembly for circuit refilling.

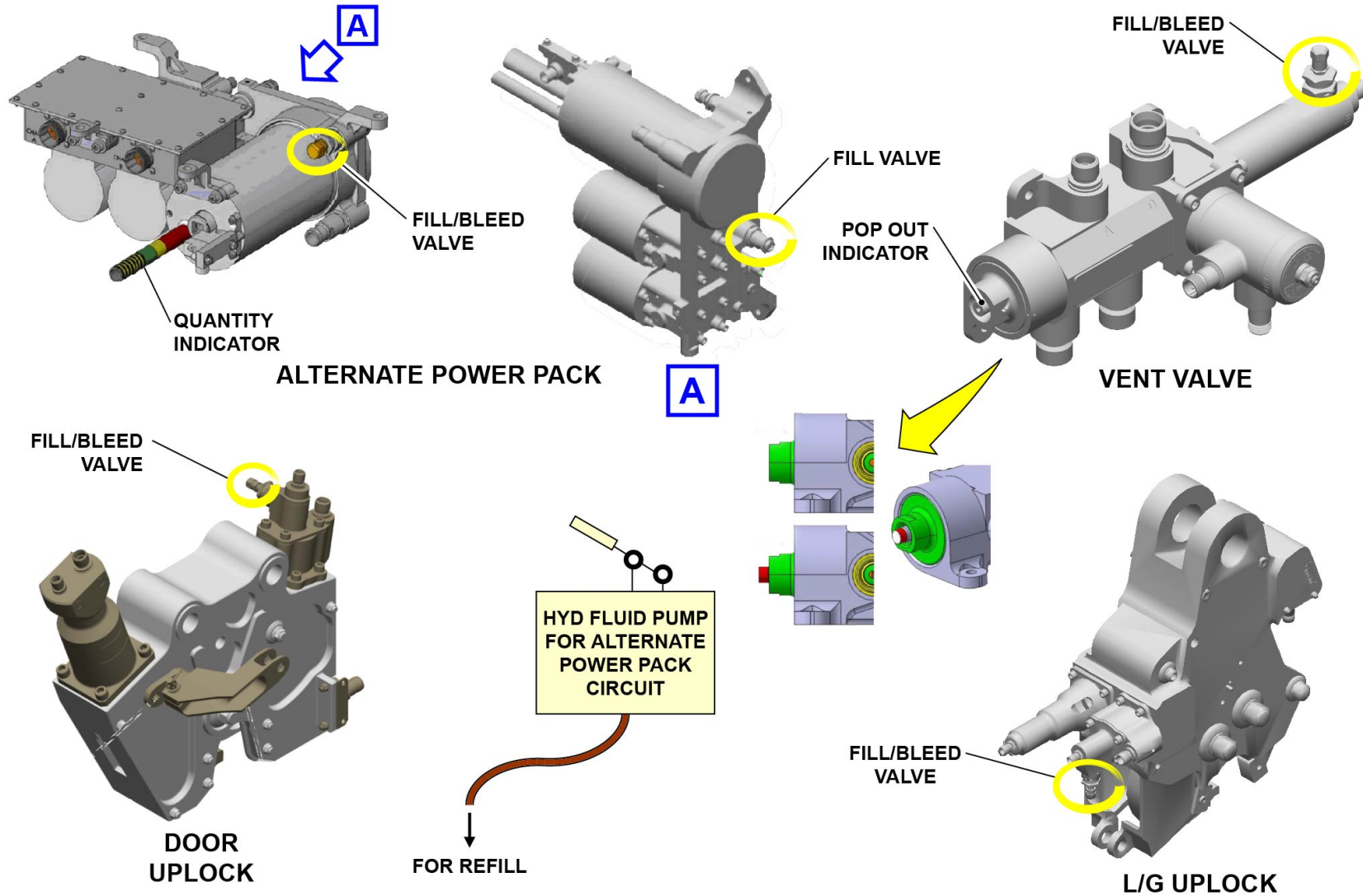

HYDRAULIC COMPONENTS DESCRIPTION

V1813401 - V01T0M0 - VM32D6FFALL.3001

LANDING GEAR ALTERNATE EXTENSION SYSTEM DESCRIPTION (3)

Alternate Extension Principle

In flight, in normal configuration, the landing gears and doors are closed and unlocked.

The alternate extension system is used only if the normal system is unserviceable to do the extension.

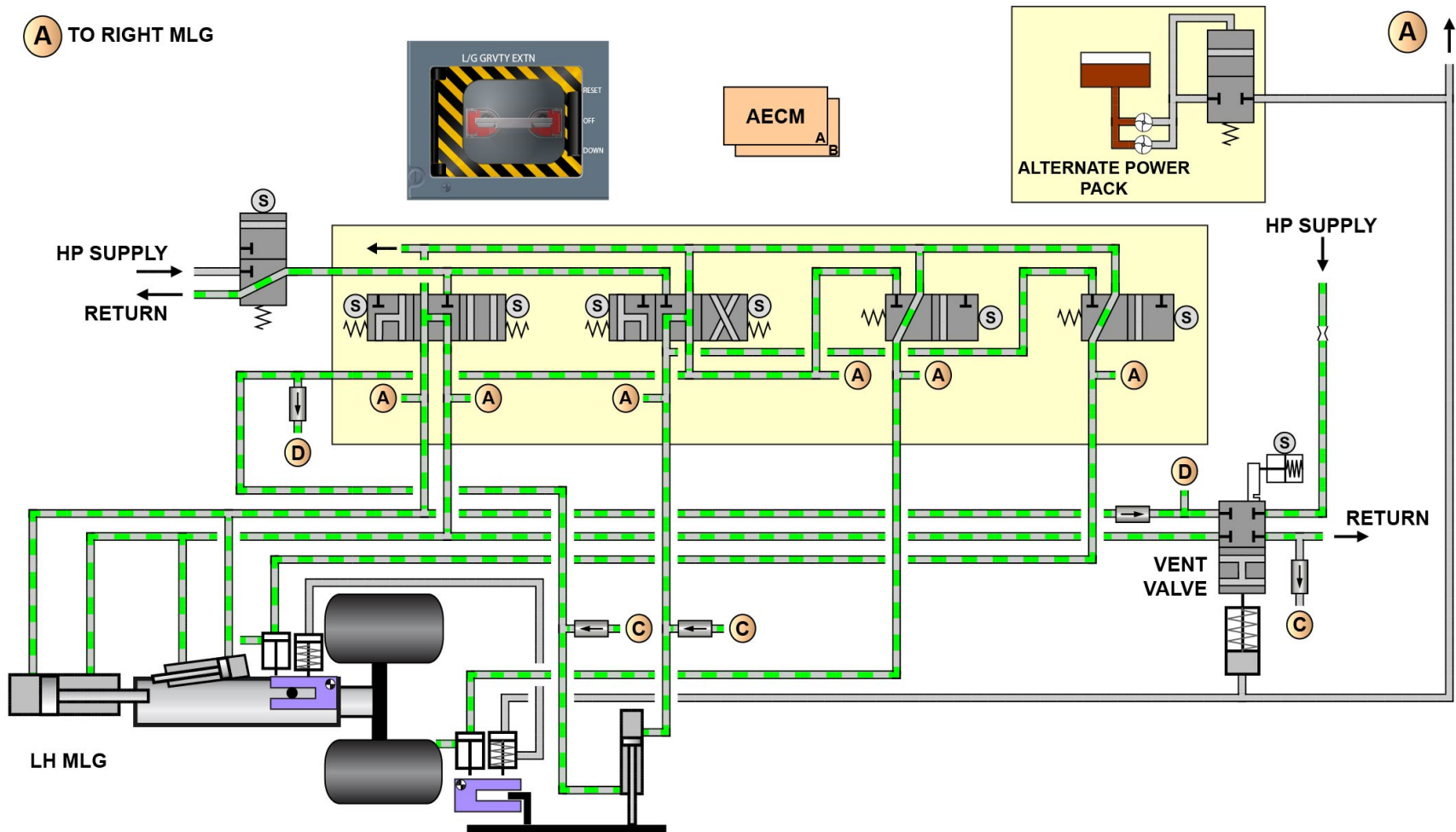

ALTERNATE EXTENSION PRINCIPLE

V1813401 - V01T0M0 - VM32D6FFALL.3001

LANDING GEAR ALTERNATE EXTENSION SYSTEM DESCRIPTION (3)

Alternate Extension Principle

The gravity extension switches give the down position signal to the AECMs to start the alternate extension sequence.

The AECMs:

- Electrically isolate the NLG and MLG isolation valves and thus make sure that the normal hydraulic system is connected to the return circuit
- Supply electrical power to the alternate power packs pumps.

While the pressure increases in the alternate hydraulic system:

- The vent valves are pushed to the vent position. A mechanical lock latches the valve in the vent position.
- The door uplock alternate actuators unlock the door uplocks and thus release the doors.
- After the doors are released, the gear alternate actuators unlock, thus release the gears.
- The doors are opened by gravity and the gears by gravity and downlock springs (see Landing Gear (L/G) and doors module).

The pressure decreases in the motor pump, but:

- The vent valves stay open because of the mechanical latch
- The AECM keeps the isolation valves electrically isolated, thus the LGERS normal hydraulic circuit is connected to the return pressure until the gravity extension switches are set to reset.

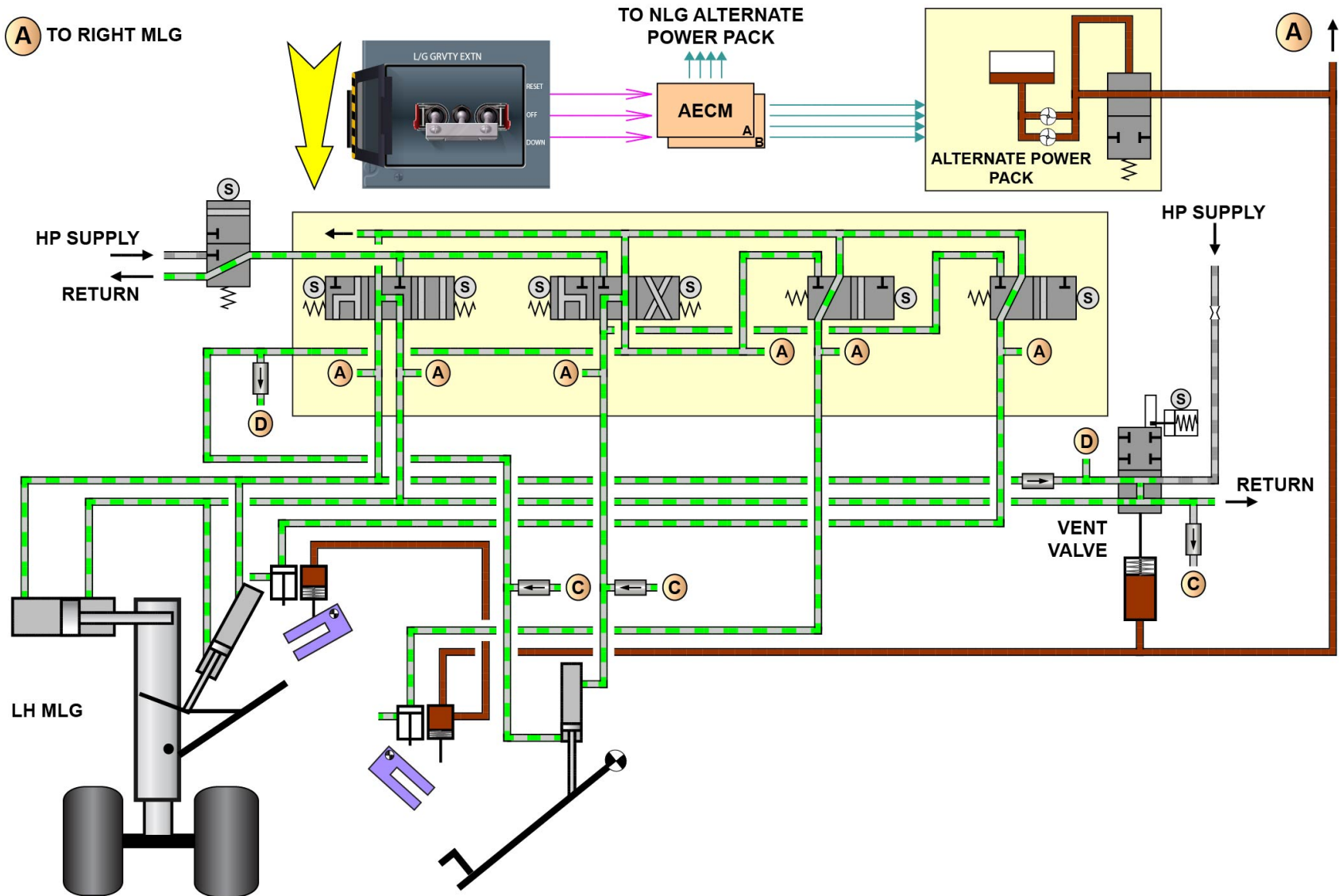

ALTERNATE EXTENSION PRINCIPLE

V1813401 - V01T0M0 - VM32D6FFALL.3001

LANDING GEAR ALTERNATE EXTENSION SYSTEM DESCRIPTION (3)

Alternate Extension Principle

All the L/G doors stay open after L/G alternate extension. This configuration can be dangerous for people working around the A/C. It is necessary to obey the safety precautions that follow before to do a system reset or other activity near the L/G areas:

- Install the L/G safety pins.
- Move the Ground Door Opening (GDO) control handles to the open position to hydraulically isolate the doors.
- Put all the safety collars in the L/G door actuators.

The flight crew or maintenance staff may start the alternate extension reset, depending on the situation. This is done by moving the switches to the RESET position.

The hydraulic high pressure supply must be "ON" to fill all the actuator chambers through the vent valve, to prevent actuator cavitations.

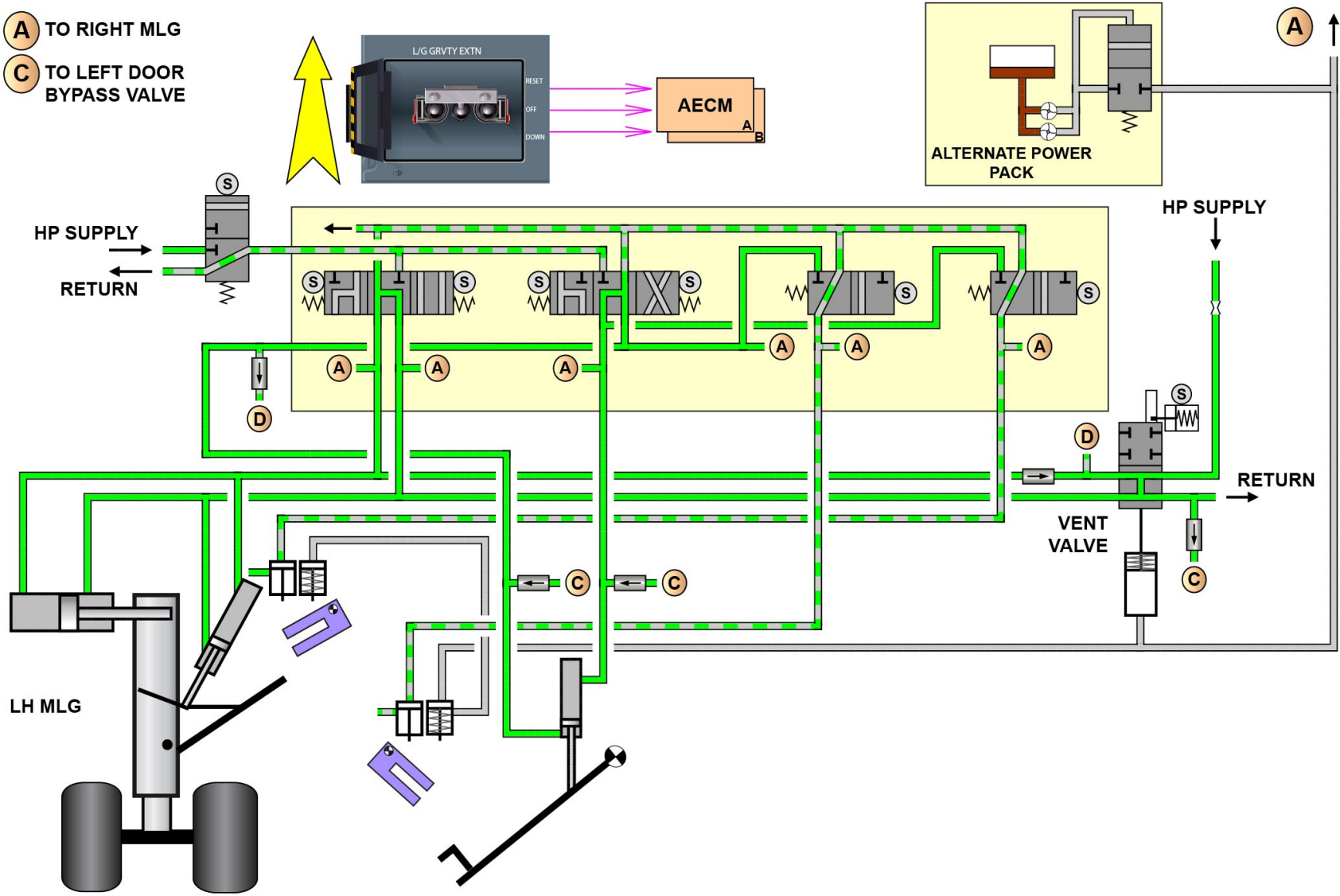

A TO RIGHT MLG
C TO LEFT DOOR BYPASS VALVE

ALTERNATE EXTENSION PRINCIPLE

V1813401 - V01T0M0 - VM32D6FFALL.3001

LANDING GEAR ALTERNATE EXTENSION SYSTEM DESCRIPTION (3)**Alternate Extension Principle**

After an interval of 5 minutes (to keep the gear and door actuator filled), the AECMs energize the baulk solenoid of the vent valves. This releases the latch and lets the vent valve go back to its normal (closed) position. The electrical supply is then connected again (if necessary) to the isolation valves and thus the normal hydraulic supply is connected again.

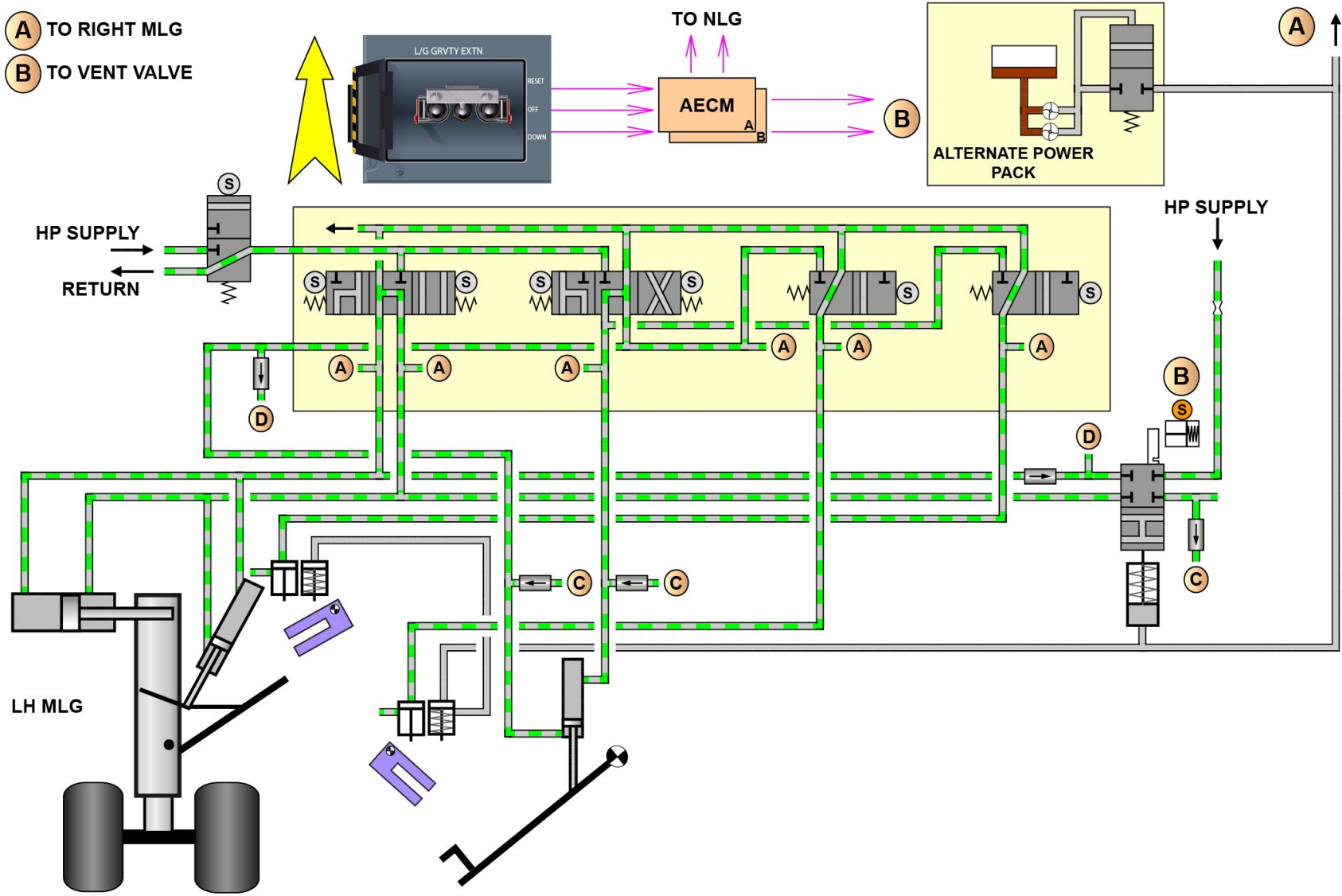

ALTERNATE EXTENSION PRINCIPLE

V1813401 - V01T0M0 - VM32D6FFALL.3001

LANDING GEARS CONTROL AND INDICATING (2/3)

Landing Gear System - General (2)

The controls used to operate the L/G are:

- L/G Control lever,
- Free Fall switches.

The indications for the L/G system are:

- On the ECAM Wheel page,
- On the lower part of the PFD.

Ground Door Opening Handles for NLG and MLGs.

L/G Normal Operation (3)

The L/G control lever, installed in the cockpit, controls the normal L/G extension and retraction. It has two positions:

- UP to retract the L/G and doors,
- DOWN to extend the L/G and doors.

A red arrow close to the L/G control lever flashes if one or more L/Gs are not downlocked with the A/C in landing configuration (and below 750 ft).

The ECAM wheel page shows the L/G and doors positions and the related hydraulic system status.

To indicate each gear position there is one triangle per gear. It is green with vertical bars when the gear is downlock and red when the gear is not downlocked.

The triangles disappear when the gears are uplocked.

The gear position indication for each gear is based on a voting logic of the LGCIS 1 and 2 and independent circuits.

To indicate the door status there is one symbol per MLG door and two for the NLG doors. The indication is green when the door is up, down or in transit and operates normally.

On the lower part of the PFD a green triangle is visible when all the gears are down and locked based on a voting logic of the LGCIS 1 and 2 and independent circuits.

When the flight crew sets the landing gear lever to UP for landing gear retraction:

1. The isolation solenoid valve is open to supply the hydraulic fluid.
2. The door uplock solenoid-valve is energized to release the doors.
3. The door open selector-valve is energized to open the doors.
4. When the doors are fully opened, the gear retract solenoid-valve is energized to retract the landing gears.
5. When the landing gears are retracted and uplocked, the door close selector-valve is energized to close the doors.
6. When the doors are closed and uplocked, the isolation valve is de-energized and closed.

When the flight crew sets the landing gear lever to DOWN for landing gear extension:

1. The isolation solenoid valve is open to supply the hydraulic fluid.
2. The door uplock solenoid valve is energized to release the doors.
3. The door open selector valve is energized to open the doors.
4. When the doors are fully opened, the gear extend solenoid valve is energized to extend the landing gears.
5. When the landing gears are fully extended and downlocked, the door close selector-valve is energized to close the doors.
6. When the doors are closed and uplocked, the isolation valve is de-energized closed.

L/G NOT LOCKED DOWN & L/G DOOR NOT CLOSED (3)

L/G GEAR NOT LOCKED DOWN warning is provided whenever the landing gear position is not consistent with the landing gear selector lever position (after a certain time). Sequence is monitored by the CPIOMs (LGERS application).

The L/H MLG downlock symbol is displayed in red.

In this case, a free fall will be initiated through the L/G gravity switch to set all the L/Gs to the downlock position.

There are three L/G GRaViTY SWs located on the L/G GRVTY control panel. These SWs are connected together with a removable link and have three positions:

- RESET,
- OFF,
- DOWN

A minimum of two switches is necessary to start the alternate (free fall) extension.

The specific indications on the ECAM Wheel page during the free fall extension sequence are:

- L/G GRVTY EXTN IN PROGRESS stays visible and it disappears once the extension sequence is finished.

On the lower part of the PFD a triangle is displayed and corresponds to the 3 L/Gs downlock status based on a voting logic of the LGCIS 1 and 2 and independent circuits.

A "L/G DOORS NOT CLOSED" ECAM warning is provided if any gear door is not detected up and locked (closed) after completion of a gear extend or retract cycle. Sequence is monitored by the CPIOMs (LGERs application). The L/H MLG door symbol is displayed in amber.

L/H MLG UPLOCK FAULT (3)

If an Uplock assembly is detected in the UP position with the corresponding L/G in the DOWN position, a "L/G GEAR UPLOCK FAULT" message is displayed.

On the ECAM wheel page, the corresponding uplock assembly is displayed in amber.

L/G CTL 1+2 FAULT (3)

A warning "L/G CTL 1+2 FAULT" is provided to indicate the total loss of the Normal Extension / Retraction systems (LGCIS 1 and 2).

This message corresponds to a dual system failure or combination of components failure in both systems.

In this situation, L/G retraction is impossible. Extension is only possible with the alternate extension system.

Alternate Extension (Free Fall) (2)

The alternate extension (free fall) sequence is initiated through the L/G control panel.

There are three L/G GRaViTY switches located on the L/G GRVTY control panel. They operate the free fall system. These SWs are connected together with a removable link and have three positions:

- RESET,
- OFF,
- DOWN

At least two switches are necessary to start the extension sequence

The specific indications on the ECAM Wheel page during the free fall extension sequence are:

- L/G GRVTY EXTN IN PROGRESS stays visible and it disappears once the extension sequence is finished.

On the lower part of the PFD a green triangle is visible when all the gears are down and locked.

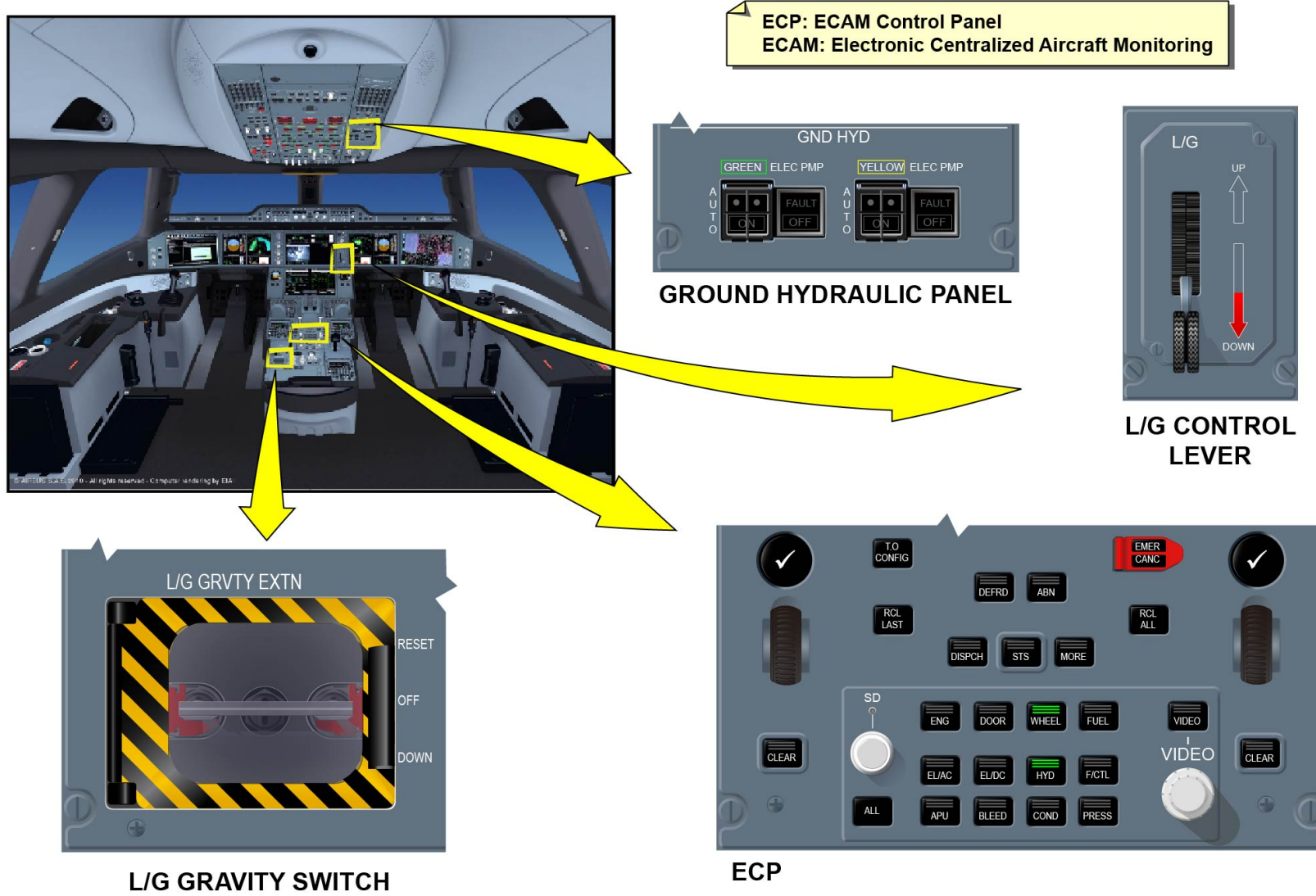

LANDING GEAR SYSTEM - GENERAL (2) ... ALTERNATE EXTENSION (FREE FALL) (2)

V1813401 - V01T0M0 - VM321IEXTEN3001

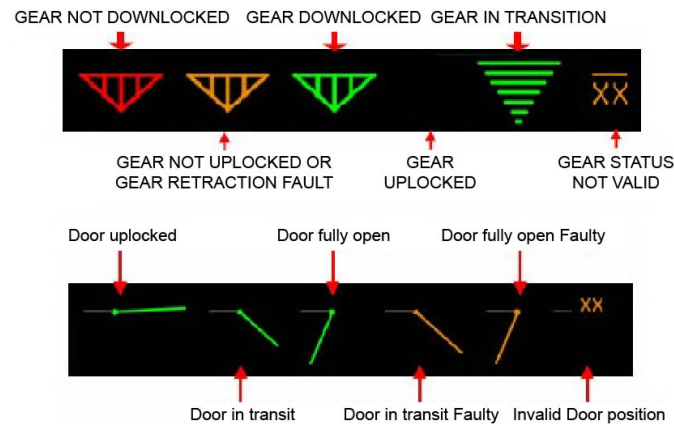
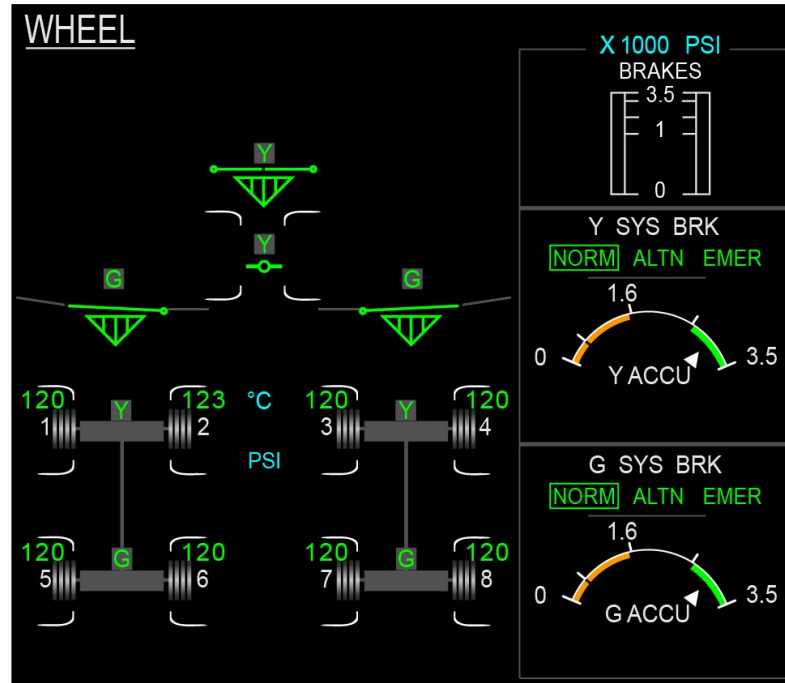

LANDING GEAR SYSTEM - GENERAL (2) ... ALTERNATE EXTENSION (FREE FALL) (2)

V1813401 - V01T0M0 - VM321HEXTEN3001

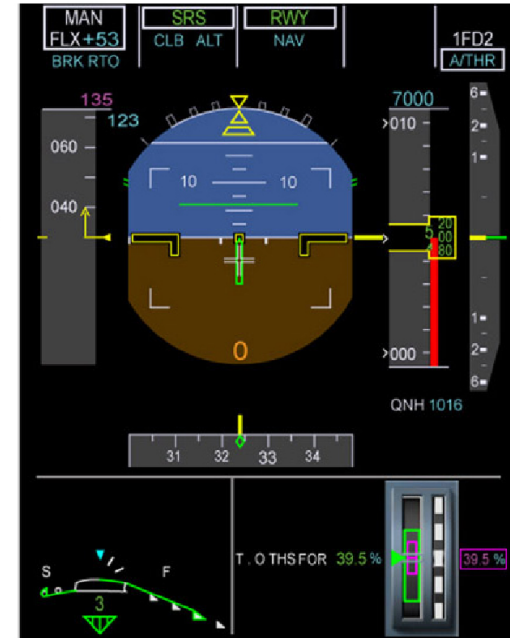

PFD

PFD: Primary Flight Display

	PFD	CONDITIONS
NOMINAL		
LANDING GEAR DOWNLOCKED		ALL THE THREE L/G GEARS ARE DOWNLOCKED
LANDING GEAR UPLOCKED		ALL THE THREE L/G GEARS ARE UPLOCKED
LANDING GEAR EXTENSION		AS SOON AS L/G LEVER IS UP UNTIL ALL L/G GEARS STATUS DATA ARE KNOWN
LANDING GEAR RETRACTION		AS SOON AS L/G LEVER IS UP UNTIL ALL L/G GEARS STATUS DATA ARE KNOWN

	PFD	CONDITIONS
DEGRADED		
LANDING GEAR NOT UPLOCKED		AT LEAST ONE L/G GEAR IS NOT UPLOCKED AFTER RETRACTION SEQUENCE
LANDING GEAR NOT DOWNLOCKED		AT LEAST ONE L/G GEAR IS NOT DOWNLOCKED AFTER EXTENSION SEQUENCE
DOORS NOT CLOSED		AT LEAST ONE L/G DOOR IS NOT CLOSED AFTER RETRACTION OR EXTENSION SEQUENCE. THE AMBER 'GEAR DOORS NOT CLOSED' ECAM ALERT IS RAISED

LANDING GEAR SYSTEM - GENERAL (2) ... ALTERNATE EXTENSION (FREE FALL) (2)

V1813401 - V01T0M0 - VM321IEXTEN3001

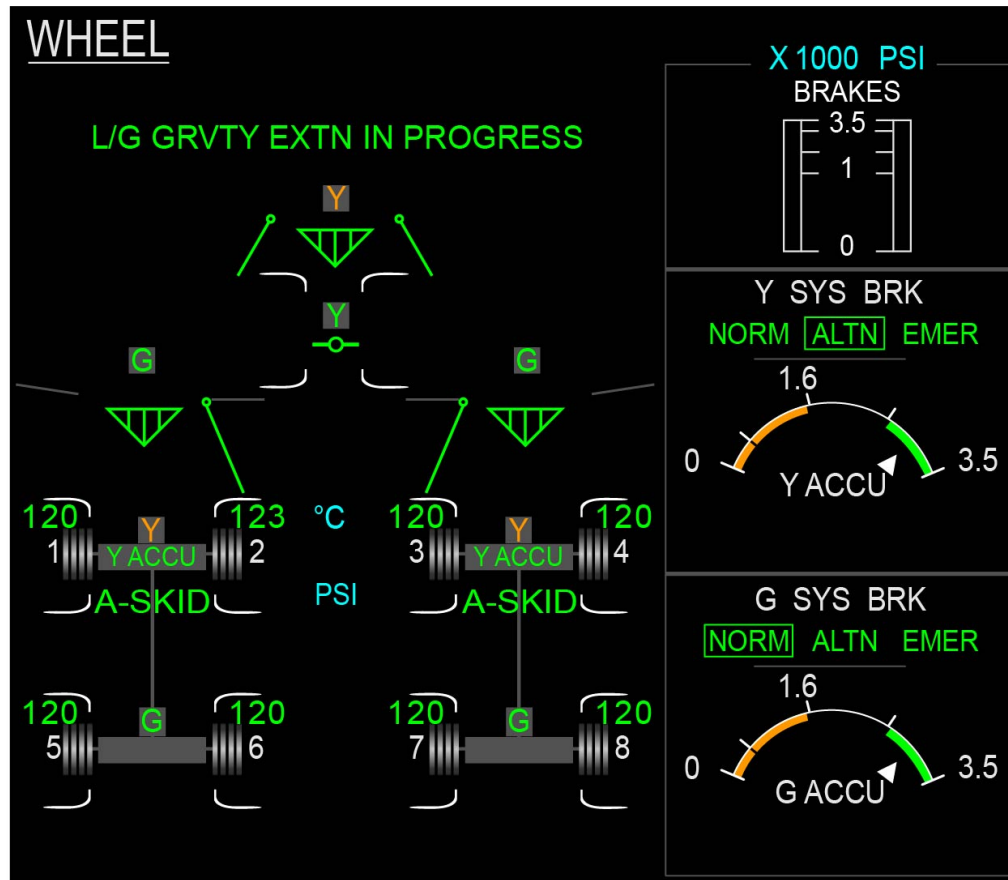

LANDING GEAR SYSTEM - GENERAL (2) ... ALTERNATE EXTENSION (FREE FALL) (2)

V1813401 - V01T0M0 - VM321IEXTEN3001

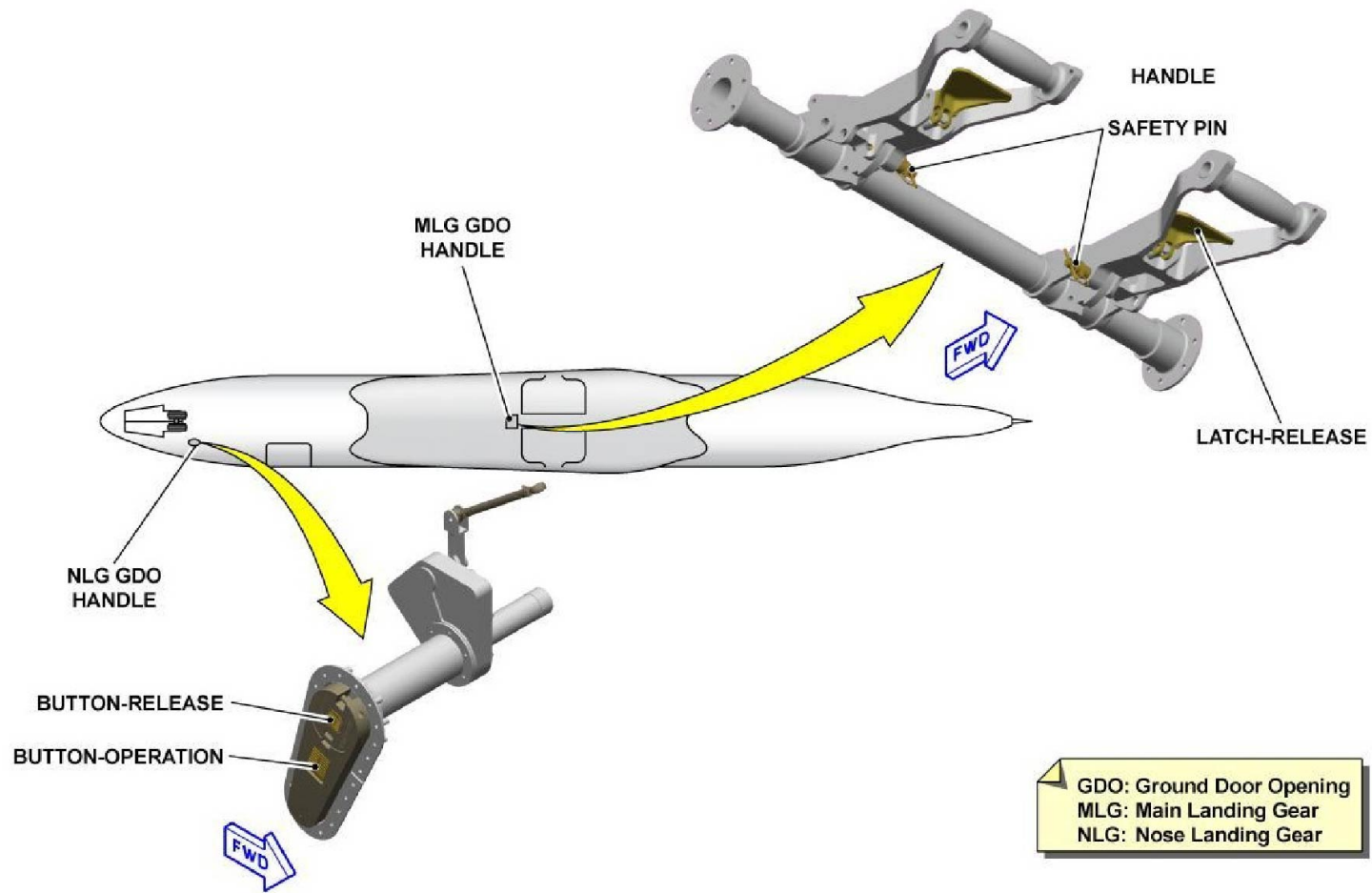

LANDING GEAR SYSTEM - GENERAL (2) ... ALTERNATE EXTENSION (FREE FALL) (2)

V1813401 - V01T0M0 - VM321IEXTEN3001

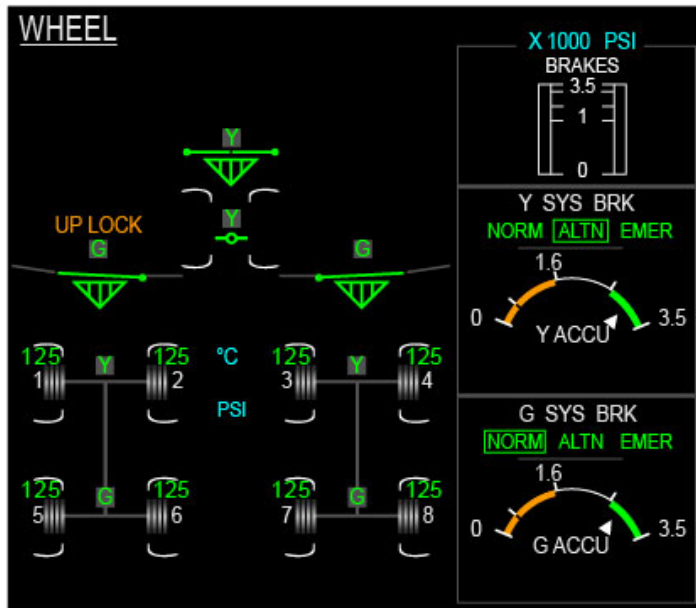

L/G NOT LOCKED DOWN LEFT MLG

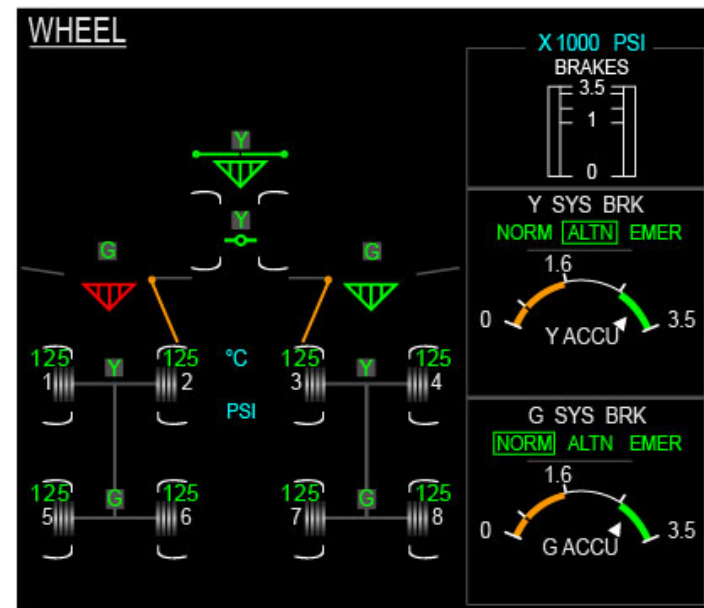

L/G DOORS NOT CLOSED MLG
L/G NOT LOCKED DOWN LEFT MLG

LANDING GEAR SYSTEM - GENERAL (2) ... ALTERNATE EXTENSION (FREE FALL) (2)

V1813401 - V01T0M0 - VM321IEXTEN3001

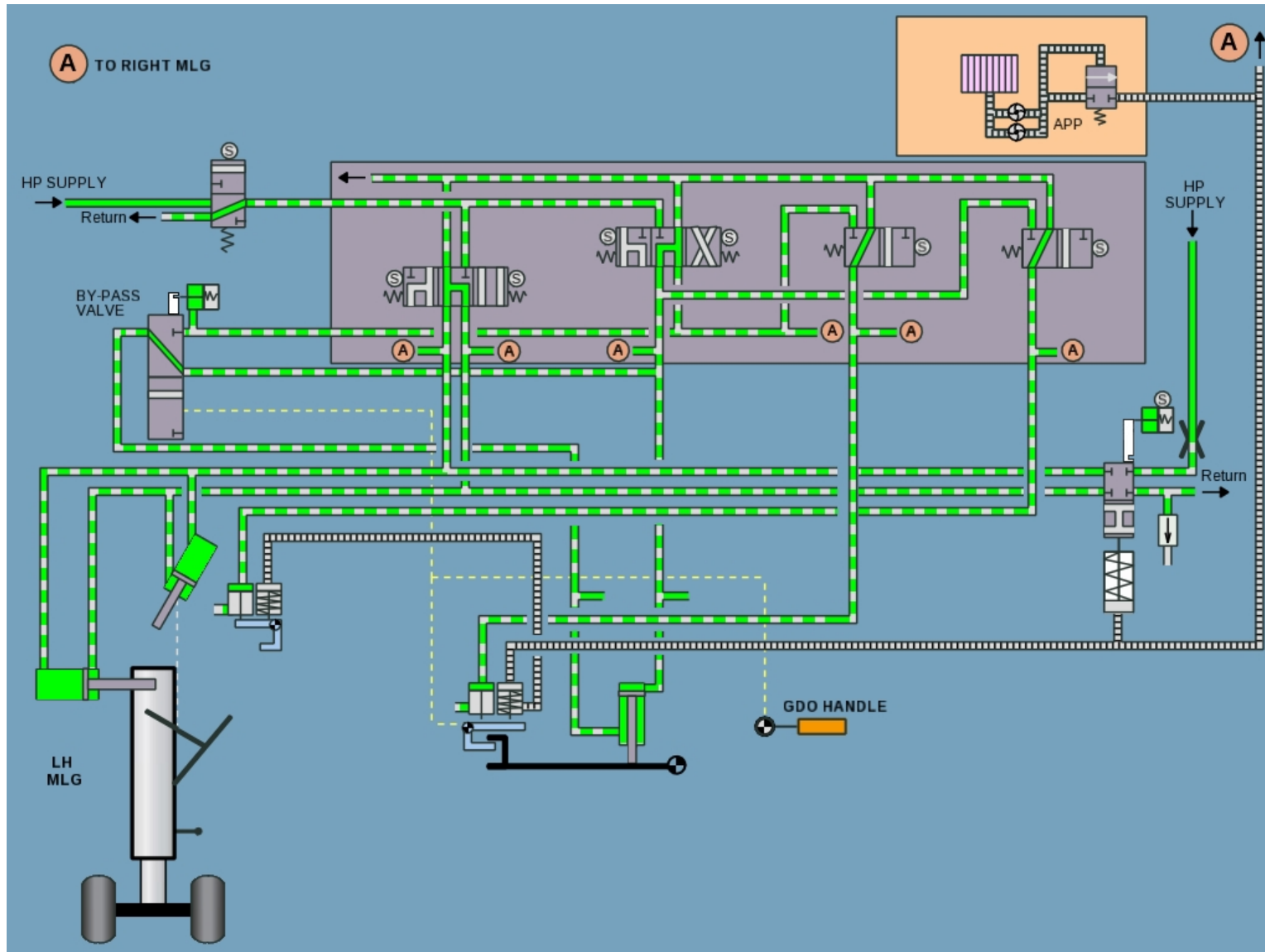

LANDING GEAR SYSTEM - GENERAL (2) ... ALTERNATE EXTENSION (FREE FALL) (2)

V1813401 - V01T0M0 - VM321IEXTEN3001

This Page Intentionally Left Blank

WHEELS AND BRAKING SYSTEMS DESCRIPTION (2)

Wheels and Brakes

The A350 Landing Gears have:

- 2 wheels for the Nose Landing Gear (NLG).
- 8 wheels for the Main Landing Gear (MLG).

The wheel assembly is made of two halves which are held together by tie bolts. Each wheel has an inflation valve for servicing and an over-pressure relief valve for over-inflation. If this is open, the tire will deflate to 0 psi.

A fusible plug prevents a main wheel or tire burst if the brake gets to a high temperature. If the temperature of the wheel increases to a specified limit, the core of the fusible plug melts and lets the tire deflate.

NOTE: After a rejected take-off, do not go near the area around the wheel for approximately one hour. When you go near, go from the front or from the rear and not from the side of the wheel.

Of the ten wheels, only the MLG wheels have brakes. The wheel brakes are of the multi-disc carbon type. The piston housing is a single cavity which is supplied with hydraulic pressure. The piston housing also includes a quick-release half coupling and a bleed valve. Two brake wear indicator-pins are installed on each wheel brake. Brake rods connect the bottom of the sliding tube to each brake. They send the torque loads from the brakes to the sliding tube.

There are two wheel groups. The forward group (brakes 1 to 4) is supplied by the Yellow hydraulic system. The rear group (brakes 5 to 8) is supplied by the Green hydraulic system.

WHEEL NUMBERING

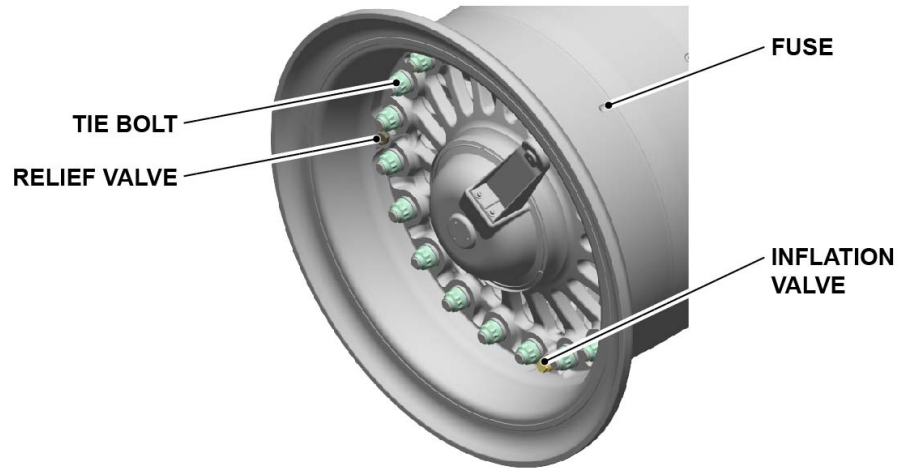
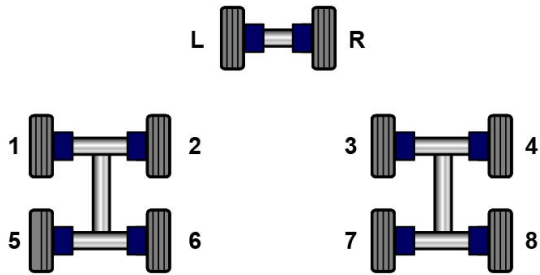

WHEEL GROUP

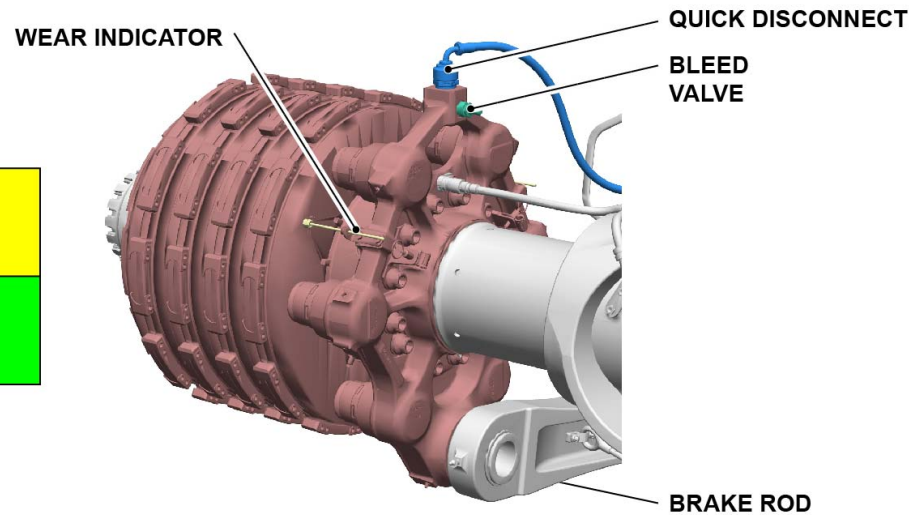
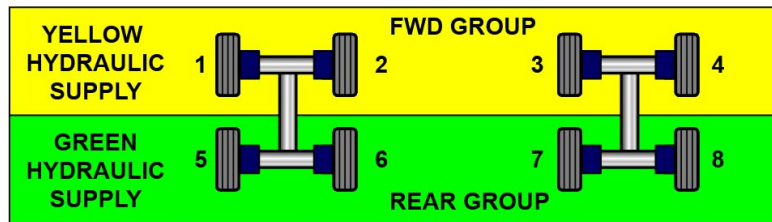

WHEELS AND BRAKES

V1813401 - V01T0M0 - VM32D7BRAKE2301

WHEELS AND BRAKING SYSTEMS DESCRIPTION (2)

Braking Control and Monitoring

The Braking Control System (BCS) has four modes of operation:

- Normal
- Alternate, with or without anti-skid
- Emergency
- Parking/Ultimate.

Each wheel group can operate independently in normal, alternate or emergency modes (for example, brakes 1 to 4 can operate in normal braking mode and brakes 5 to 8 in emergency mode).

The normal braking mode uses hydraulic power from the HP hydraulic systems. The hydraulic power for the alternate, emergency, parking/ultimate modes is supplied by two accumulators.

The CPIOMs BCS application and the Remote Braking Control Units (RBCUs) control and monitor the braking modes. If a failure occurs on the AFDX network or the CPIOMs, the RBCUs are capable to provide all braking modes control and monitoring.

The normal braking circuit has the architecture that follows:

- One pressure limiter valve for each wheel group, that decreases the hydraulic pressure (3400 psi)
- Two Normal Brake Selector Valves (NBSELVs) for each wheel group. They open to connect the main HP hydraulic supply to the Normal Servo Valve (NSV) when braking is commanded. They also isolate the braking circuit from the aircraft hydraulic supply when braking is not used.
- Four NSVs for each wheel group, which control and adjust the pressure to the brake units. They also give anti-skid protection.
- Fuses (safety valves), which isolate the brake supply from a possible external leakage downstream of the fuse
- Pressure transducers, which send the pressure feedback signals.

The alternate and emergency modes have the same architecture. The alternate braking circuit has the components that follow:

- Two accumulators, one for the Yellow hydraulic system (wheels 1, 2, 3, 4) and one for the Green hydraulic system (wheels 5, 6, 7, 8). They supply the necessary fluid flow for the system.
 - One Alternate Brake Selector Valve (ABSELV) for each wheel group. They open to connect the hydraulic supply from the accumulators to the Alternate Servo Valves (ASVs) and isolate the alternate braking circuit from the accumulators when alternate braking is not used.
 - Two ASVs for each wheel group, which control and adjust the pressure to the brake units. They also give anti-skid protection.
 - Two shuttle valves for each wheel group, which select the highest pressure supplied by the normal or alternate circuit to the single cavity brakes.
 - One Alternate Refilling Valve (ARV) for each wheel group, which opens to recharge the accumulator.
- The hydro-mechanical architecture of the parking brake system has some valves and equipment shared with the alternate/emergency braking circuit. The parking brake pressure can be applied with or without an electrical power supply. There are two Park Brake Selector Valves (PBSELVs) in the system, one on each wheel group, which are connected to the accumulators, and two ASVs for each wheel group.

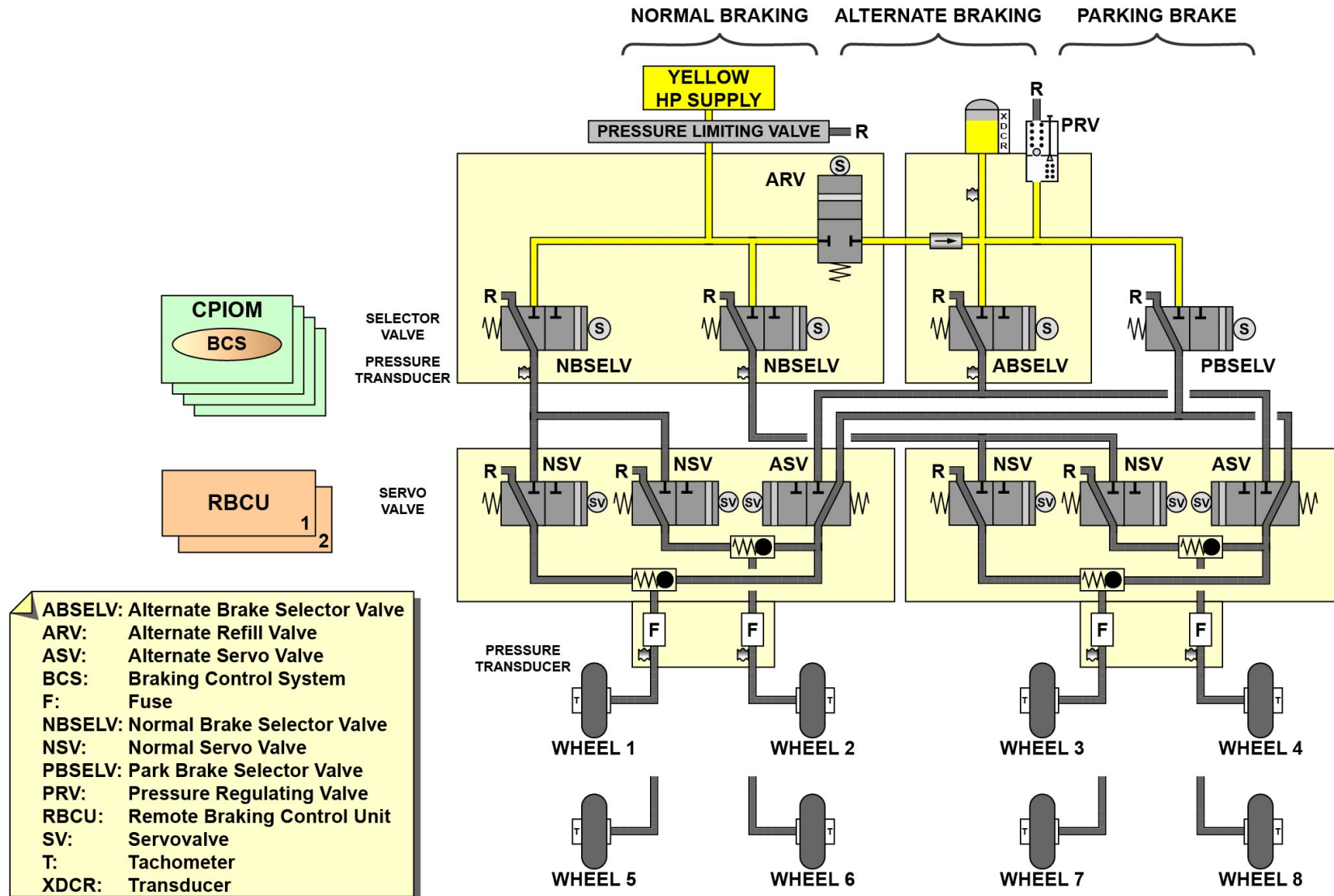

BRAKING CONTROL AND MONITORING

V1813401 - V01T0M0 - VM32D7BRAKE2301

WHEELS AND BRAKING SYSTEMS DESCRIPTION (2)

Normal Braking Mode Operation

There are two possibilities for control of the brake system:

- The primary possibility uses the CPIOMs and the RBCUs.
- The secondary possibility uses only the RBCUs.

The normal braking mode includes the functions that follow:

- Pedal braking
- Auto braking
- Retraction braking.

For redundancy purposes, the normal braking uses the CPIOMs and the RBCUs. In this mode, a braking request is sent by the pedals, the auto brake system or the retraction braking.

Electrical signals are sent to open the NBSELVs and to control the pressure to the brakes by the NSVs.

In relation to the difference between the wheel tachometers (wheel speed data) and the Air Data/Inertial Reference System (ADIRS) ground speed data received by the RBCUs, pressure is regulated by the NSVs for the anti-skid protection.

Normal braking is also possible without the CPIOM/AFDX network. The RBCUs then perform the CPIOMs functions.

NOTE: The CAPT and F/O left pedals are mechanically connected together and the CAPT and F/O right pedals are mechanically connected together.

Retraction braking does not give the anti-skid function.

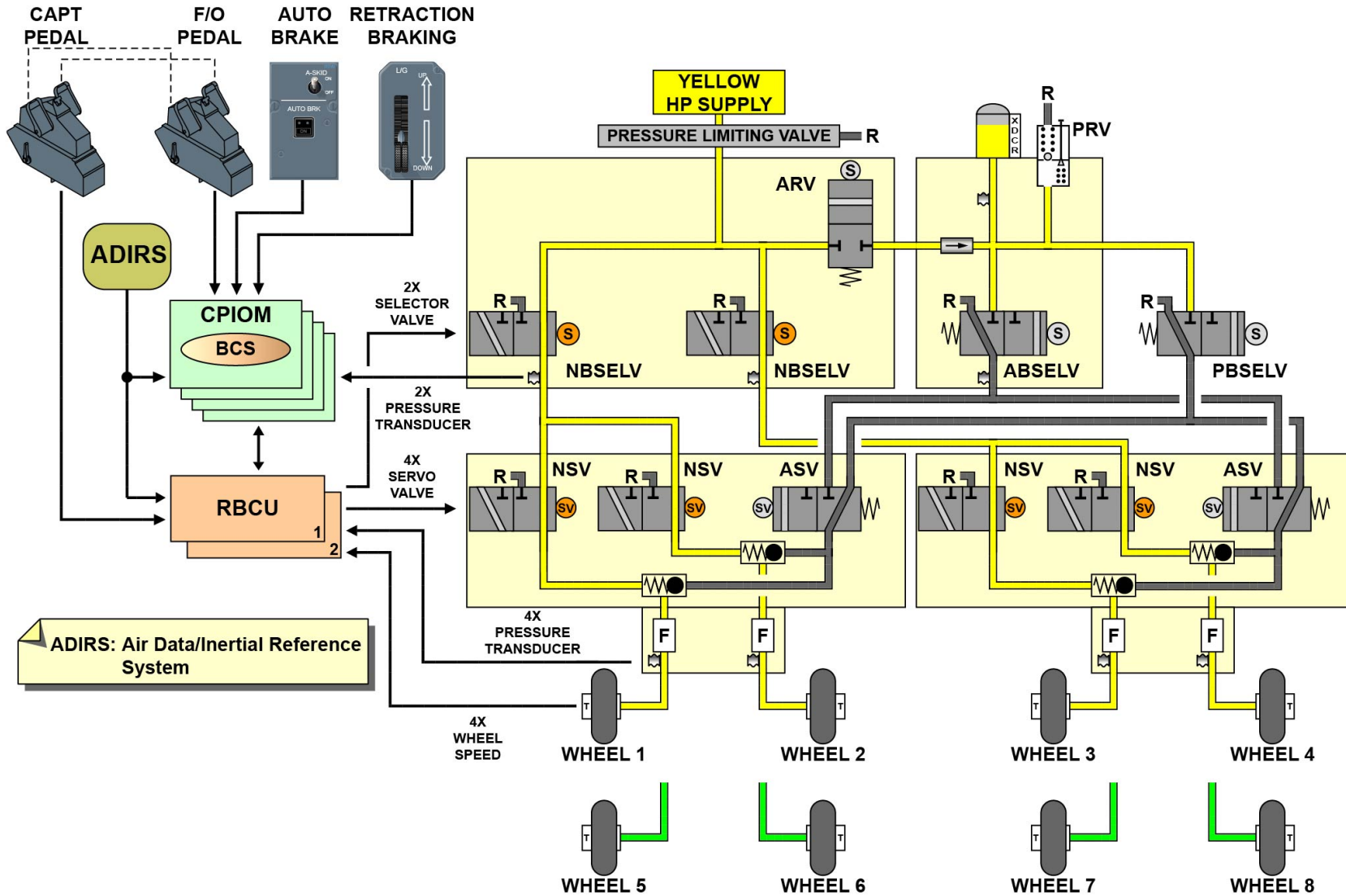

NORMAL BRAKING MODE OPERATION

V1813401 - V01T0M0 - VM32D7BRAKE2301

WHEELS AND BRAKING SYSTEMS DESCRIPTION (2)

Alternate Braking Mode Operation

If a failure occurs in normal braking mode, alternate braking with anti-skid takes over. Alternate braking with the anti-skid mode includes the functions that follow:

- Pedal braking
- Auto braking.

The CPIOMs and RBCUs give alternate braking with anti-skid. In this mode, the braking command is sent by the pedals or auto brake selection. Electrical signals are sent to open the ABSELVs and to control the pressure sent to the brakes by the ASV. Pressure is regulated by the ASVs for the anti-skid protection. As in normal braking mode, the wheel tachometers and the ADIRS send data to the RBCUs for the anti-skid function. Alternate braking is also possible without the CPIOM/AFDX network. The RBCUs then do the CPIOMS functions.

For alternate braking with anti-skid failure or an accumulator pressure of less than 1000 psi, alternate braking without anti-skid mode takes over. This mode is equivalent to alternate braking with anti-skid, but the output pressure is limited to a maximum of 1000 psi without anti-skid protection. In this mode, only pedal braking is possible.

The CPIOMs and RBCUs provide alternate braking without anti-skid mode. Alternate braking without anti-skid is also possible without the CPIOM/AFDX network. The RBCUs then perform the CPIOMS functions. The brake pressure applied and the accumulator pressure are shown on the CDS by the RBCUs and CPIOMs.

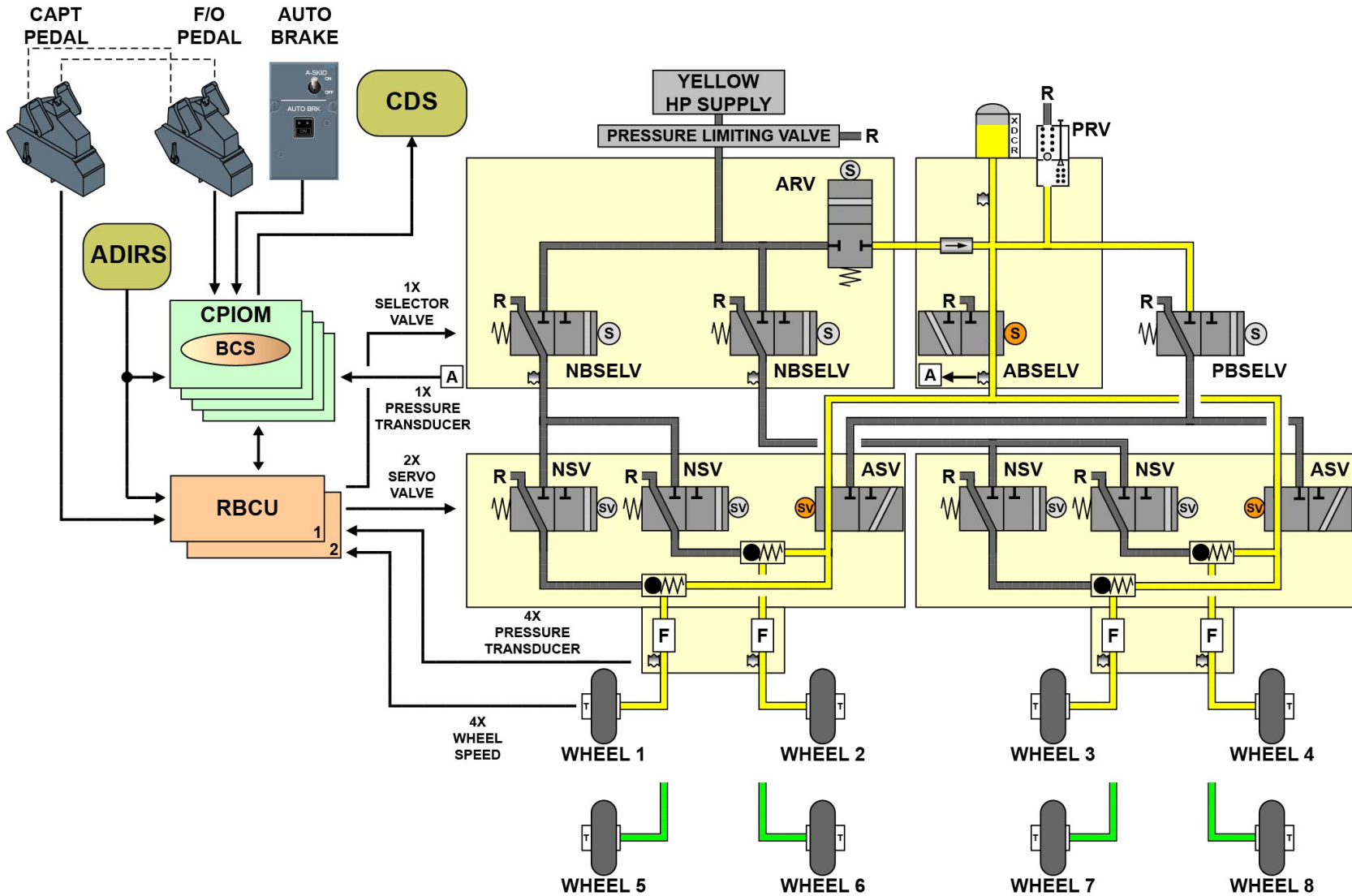

ALTERNATE BRAKING MODE OPERATION

V1813401 - V01T0M0 - VM32D7BRAKE2301

WHEELS AND BRAKING SYSTEMS DESCRIPTION (2)

Emergency Braking Mode Operation

If the anti-skid switch is set to OFF, all brakes change to the emergency mode. Emergency mode is similar to alternate braking without anti-skid, but only pedal braking is available and the maximum pressure is 1000 psi without anti-skid protection.

The emergency mode is supplied through the CPIOMs and the RBCUs. The emergency mode is also possible without the CPIOM/AFDX network. The RBCUs then perform the CPIOM functions.

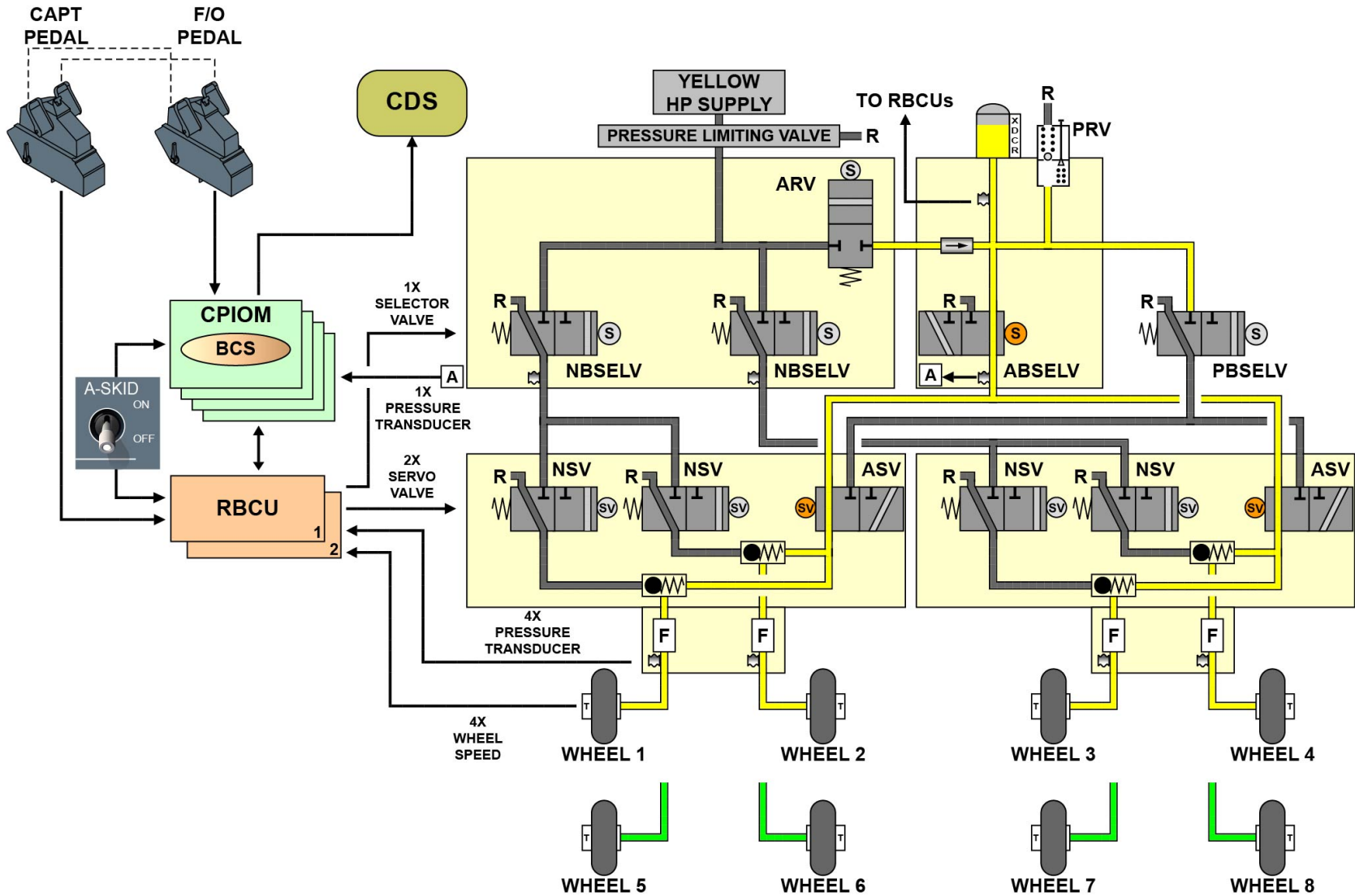

EMERGENCY BRAKING MODE OPERATION

V1813401 - V01T0M0 - VM32D7BRAKE2301

WHEELS AND BRAKING SYSTEMS DESCRIPTION (2)

Alternate Braking Mode Operation

When the "TOWING ON BAT" pushbutton switch is set to ON, the RBCU 1 is supplied from the BAT 1.

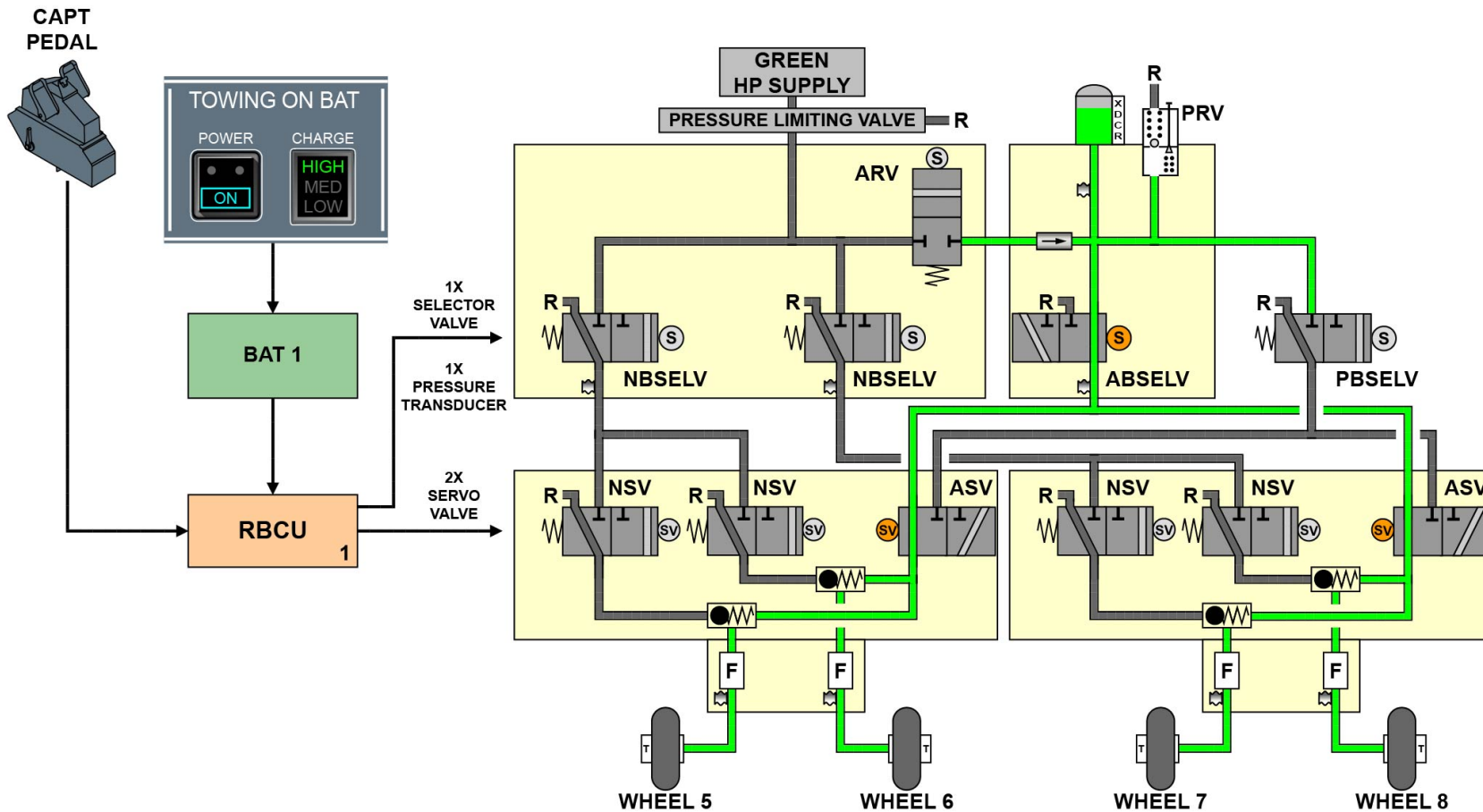

ALTERNATE BRAKING MODE OPERATION

V1813401 - V01T0M0 - VM32D7BRAKE2301

WHEELS AND BRAKING SYSTEMS DESCRIPTION (2)

Accumulator and circuit pressurization / depressurization

The ARVs are used to refill the accumulators from the aircraft hydraulic HP systems. They are manually controlled to open from an (ACCU REFILL) pushbutton in the cockpit. They are also automatically controlled to open after the engine start (Engine Master Lever to ON) and before landing (L/G lever set to DOWN). Engine Driven Pumps (EDPs) or Electric Motor Pumps (EMPs) are used to pressurize the HP systems to refill the accumulators

A pressure relief valve automatically opens if there is accumulator overpressure. A manual lever enables circuit depressurization for maintenance purposes.

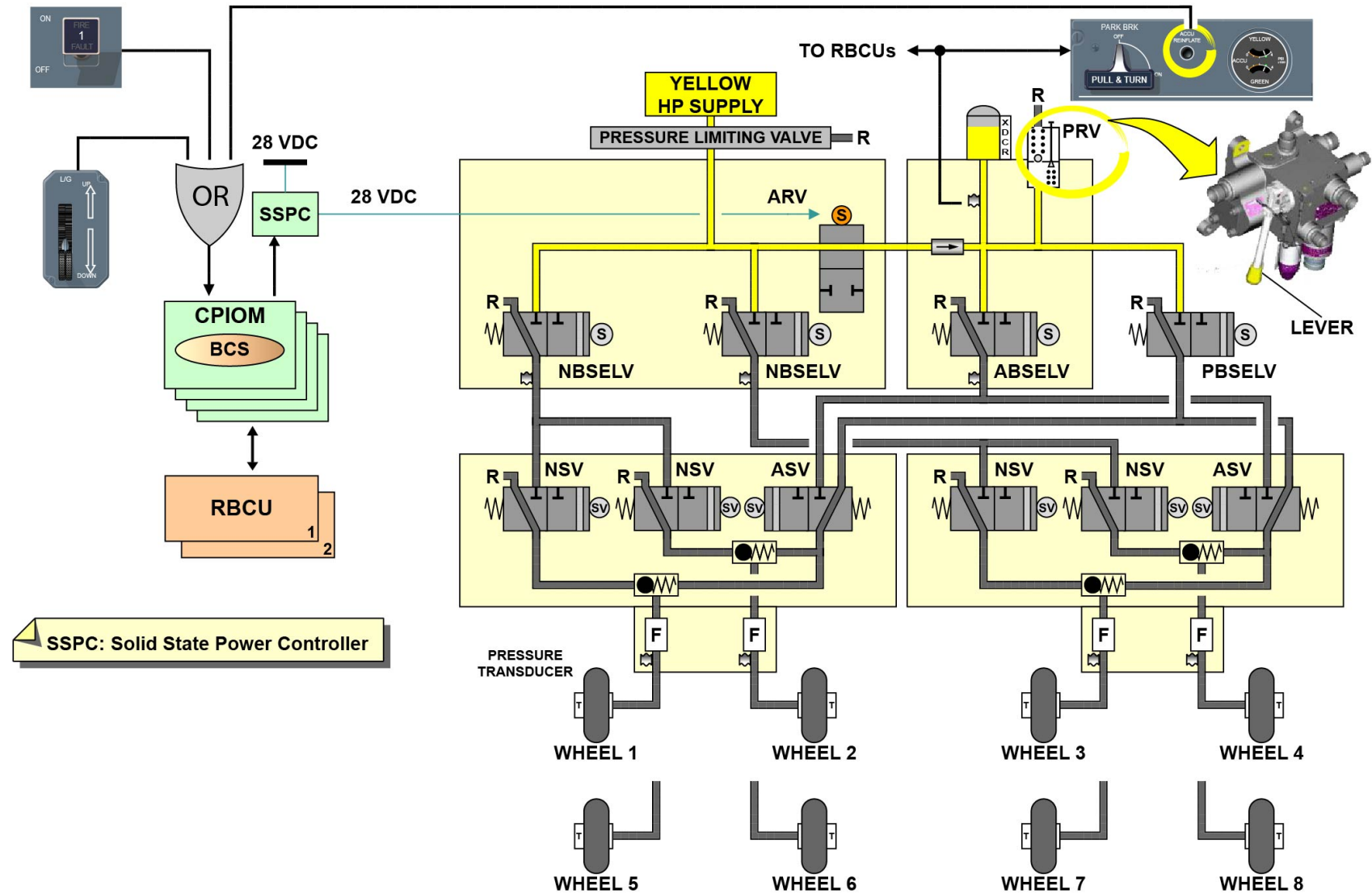

ACCUMULATOR AND CIRCUIT PRESSURIZATION / DEPRESSURIZATION

V1813401 - V01T0M0 - VM32D7BRAKE2301

WHEELS AND BRAKING SYSTEMS DESCRIPTION (2)

Parking Brake / Ultimate Braking Mode Operation

Parking brake starts when the parking brake handle is operated. The parking brake handle operates the parking brake circuit and, at the same time, supplies parking brake pressure to all the brakes.

In parking brake mode, the parking brake handle will directly control the PBSELVs to supply a maximum of 3400 psi from the accumulators to the brakes. These accumulators can supply hydraulic power for 12 hours. The CPIOMs and the RBCUs receive the parking brake selection from the position of the parking brake handle position.

If the parking brake mode is in low pressure condition, the normal braking mode can be recovered if the pedals are depressed and the related hydraulic HP system is pressurized.

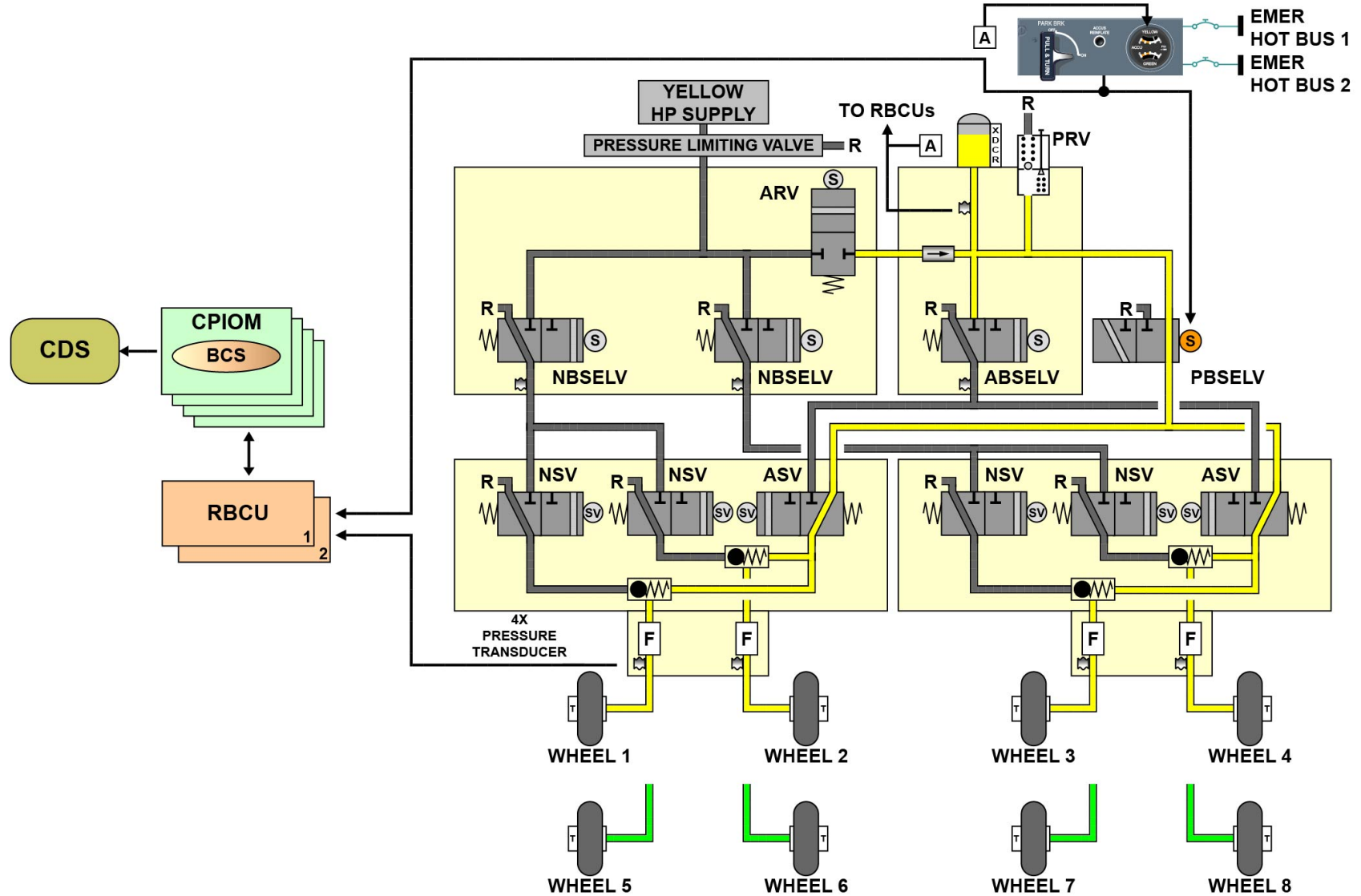

PARKING BRAKE / ULTIMATE BRAKING MODE OPERATION

V1813401 - V01T0M0 - VM32D7BRAKE2301

NORMAL BRAKING SYSTEM DESCRIPTION (3)

Normal Mode Description

For redundant control, the normal braking mode is operated independently by two sides (1 and 2). Each side has 2 CPIOMs. The Brake Control System (BCS) application is installed in the four CPIOMs. Each side has Computing (COM) and Monitoring (MON) CPIOMs. Only one side operates at a time and the other is in stand-by mode. A switchover is done at each landing gear lever DOWN selection or if a failure occurs.

There are two brake pedal assemblies: one at the CAPT position and the other at the F/O position. The mechanical inputs are sent to the Brake Pedal Transmitter Units (BPTUs) from the pedals. Manual symmetrical or differential braking is available through the brake pedals. There is no limit to the number of brake applications. The wheels are controlled independently.

When the pedals are operated (manual operation), the BPTU receives a mechanical input in proportion to the pedal deflection. The BPTU then sends the electrical signals to the CPIOMs and RBCUs in proportion to the pedal deflection.

The BCS application receives signals from:

- The BPTU
- The auto brake selection
- The Landing Gear Extension and Retraction System (LGERS) (L/G UP selection).

The BCS application calculates the command signals. The CPIOMs send these signals to the RBCUs. The RBCUs supply 28 VDC and the CPIOMs supply a ground signal to open the Normal Brake Selector Valves (NBSELVs). The RBCUs also send signals to control and adjust the Normal Servo Valves (NSVs). The NSV supplies pressure to each brake (max of 3000 psi).

The RBCUs control and monitor the system with full authority if there is a dual braking side failure or an AFDX network failure. Only pedal braking is then available (inputs from Captain's BPTU). Anti-skid protection is also available.

The RBCUs supply 28 VDC power and the F/O's BPTU supplies a ground signal to open the NBSELV. The RBCUs also send signals to control and adjust the NSVs.

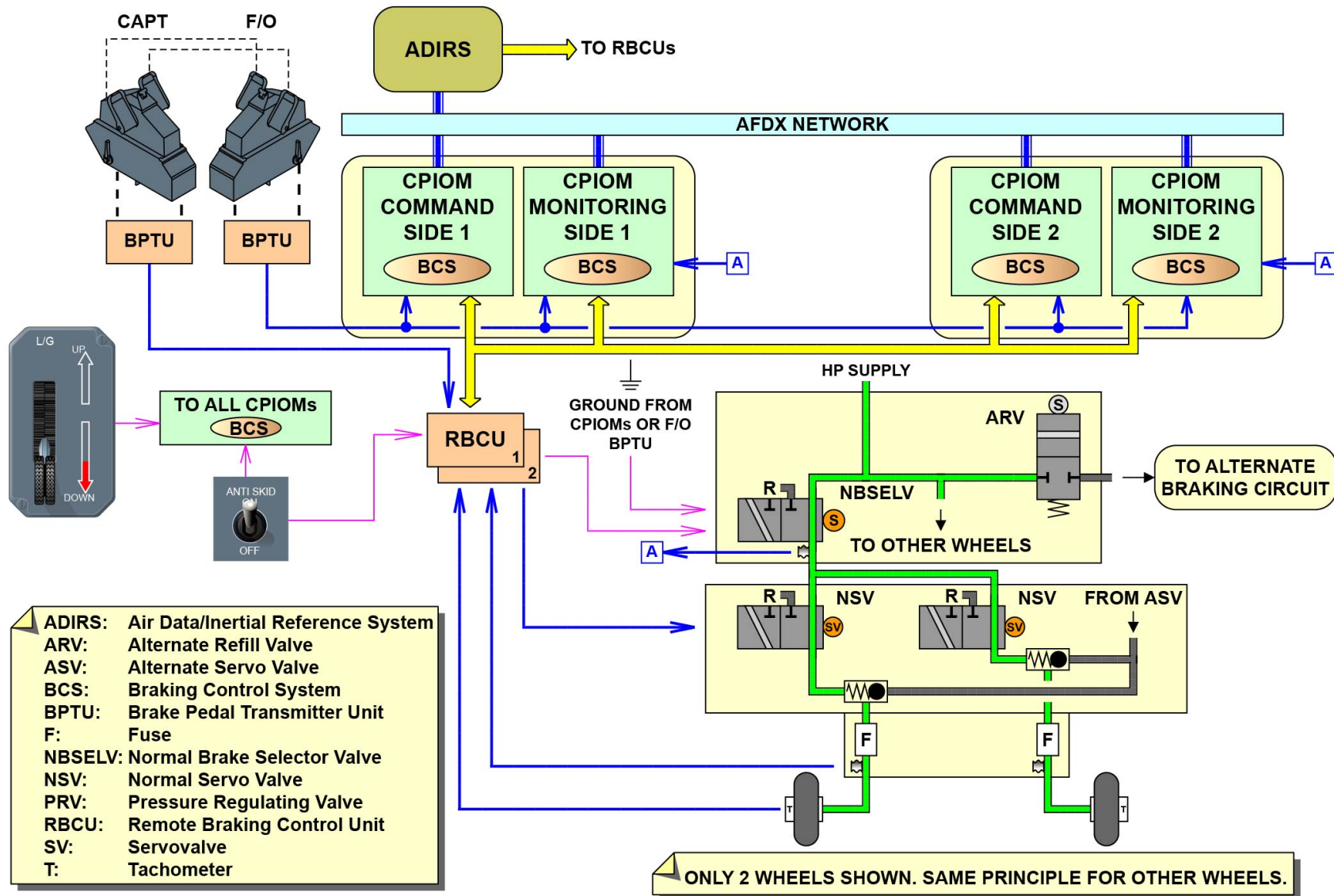

- ADIRS:** Air Data/Inertial Reference System
- ARV:** Alternate Refill Valve
- ASV:** Alternate Servo Valve
- BCS:** Braking Control System
- BPTU:** Brake Pedal Transmitter Unit
- F:** Fuse
- NBSELV:** Normal Brake Selector Valve
- NSV:** Normal Servo Valve
- PRV:** Pressure Regulating Valve
- RBCU:** Remote Braking Control Unit
- SV:** Servo valve
- T:** Tachometer

NORMAL MODE DESCRIPTION

V1813401 - V01T0M0 - VM32DDNORMB3001

NORMAL BRAKING SYSTEM DESCRIPTION (3)

Auto-Brake

The automatic braking function is used to automatically decrease the aircraft speed on the ground. It has two modes, Rejected TakeOff (RTO) and landing and each one gives a specific deceleration rate in relation to the aircraft in-flight/on-ground state.

The landing mode has two braking modes:

- Classic Auto brake
- Brake to Vacate (BTV).

The BTV uses data from the Airport Navigation Function (ANF). The PRIMARY Computers (PRIMs) manage the function. The Auto-brake system is armed/engaged with the auto-brake control panel: classic or BTV. Automatic braking is disarmed/disengaged if the brake pedals are used.

The braking system receives data through the AFDX from:

- Flight Control PRIMARY (PRIM) (and SECONdary Computers (SECs)) which receive data about the autopilot, spoilers deployment order, and tachometers.
- BTV selection
- Antiskid switch position
- Air Data/Inertial Reference System (ADIRS) which receives data about deceleration, ground and air speed.

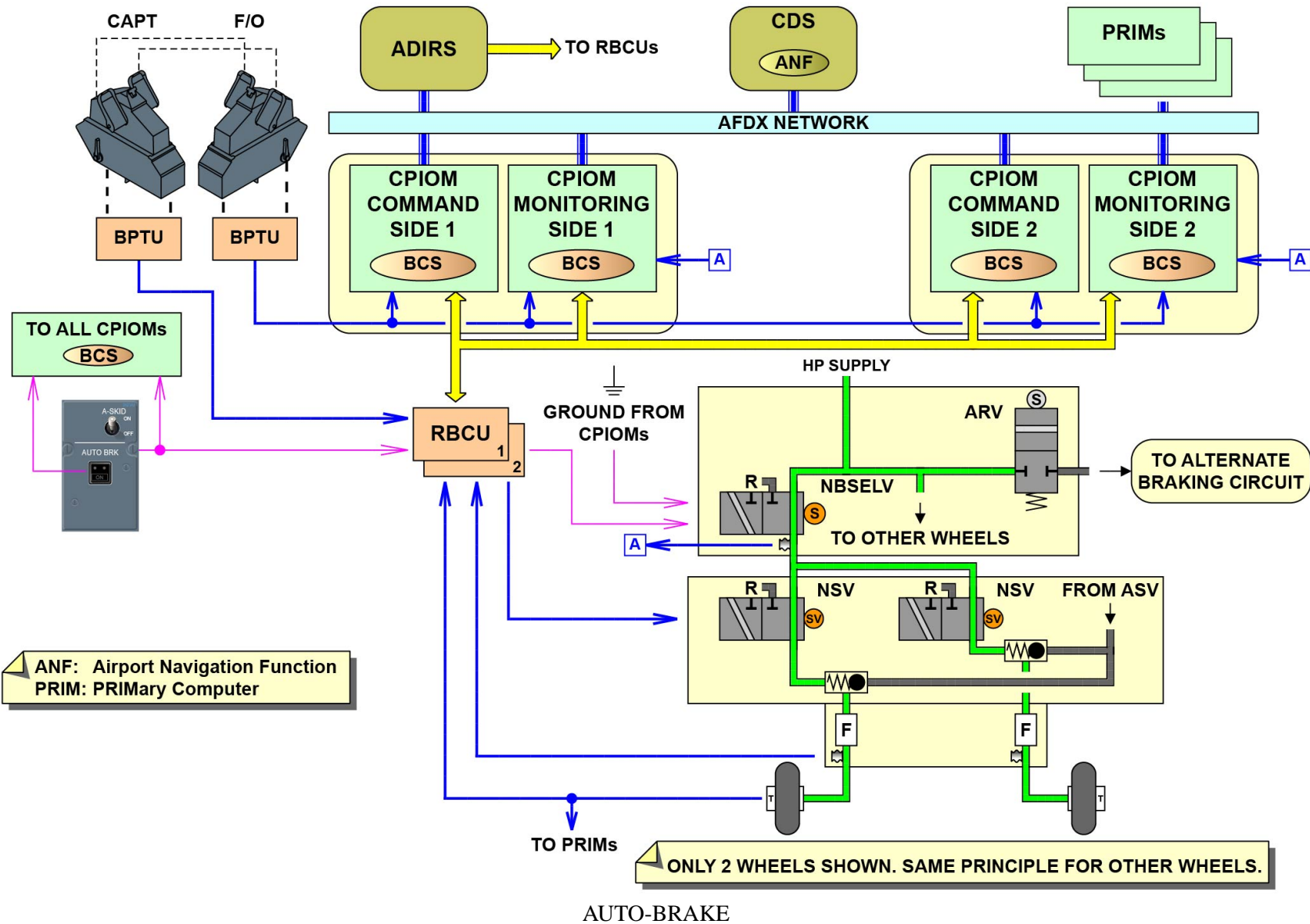

V1813401 - V01T0M0 - VM32DDNORMB3001

NORMAL BRAKING SYSTEM DESCRIPTION (3)

Braking, Auto-Brake and Anti-skid Conditions and Logics

Normal braking conditions logic is:

- The Main Landing Gears (MLGs) weight on wheels
- Normal hydraulic system available
- The anti-skid switch set to ON.

The auto-brake RTO mode operates when:

- All the arming conditions are satisfied.
- The ground spoilers extend.
- The aircraft ground speed is more than a given threshold 40 kts.

The auto-brake classic landing mode operates when:

- All the arming conditions are satisfied.
- The ground spoilers are extended.
- The NLG is on the ground.

The auto-brake landing mode is disarmed or stopped when:

- An arming condition for the auto-brake classic landing mode is lost.
- The ground spoilers retract.
- The flight crew applies sufficient pedal deflection on one or the two brake pedals.
- The flight crew pushes one of the Autothrust (A/THR) instinctive disconnect pushbuttons.

The anti-skid system provides maximum braking efficiency, minimum tire wear and decreases the risk of tire burst. The anti-skid system also prevents braking before wheel spin-up. The RBCU uses the wheel speed and aircraft ground-speed differences to control the anti-skid operation. The wheel speed is sent by tachometers installed on each braked wheel. The ADIRS gives the aircraft speed.

LOGICS

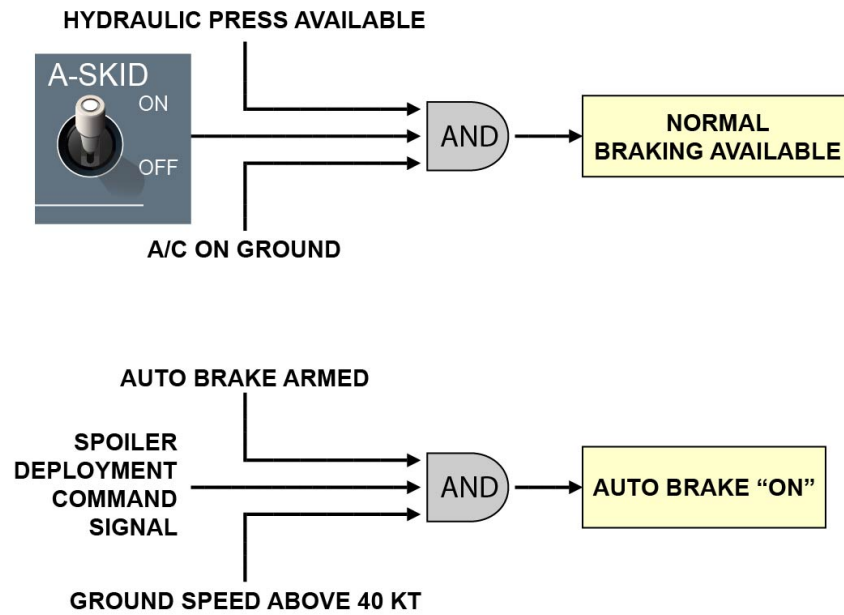

ANTI SKID PROTECTION

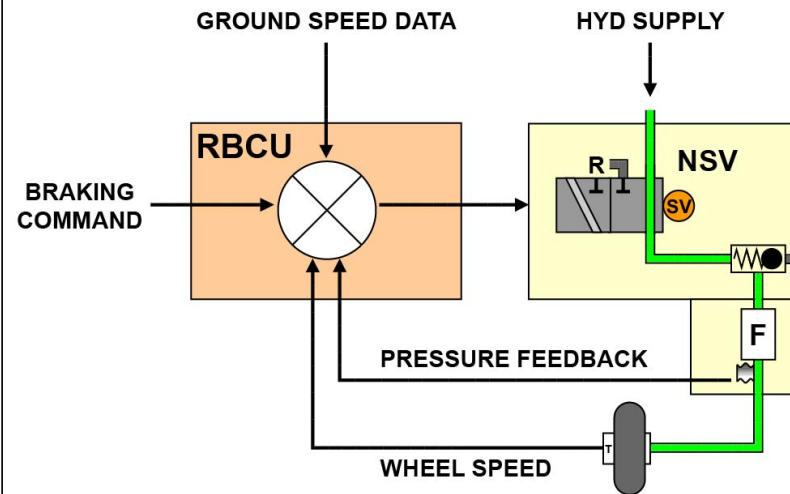

BRAKING, AUTO-BRAKE AND ANTI-SKID CONDITIONS AND LOGICS

V1813401 - V01T0M0 - VM32DDNORMB3001

NORMAL BRAKING SYSTEM DESCRIPTION (3)

Brake to Vacate

The BTV is used to decelerate the aircraft automatically, and to leave the runway on to the runway exit selected by the pilot. The BTV calculates a deceleration sequence to:

- Get the most satisfactory aircraft braking and a minimum runway occupation time
- Make sure the aircraft gets to the selected exit at the good runway exit speed.

The runway overrun prevention system gives data on the runway overrun risk during landing. This system has a Runway Overrun Warning (ROW) and a Runway Overrun protection (ROP). "RWY TOO SHRT" visual feedback comes into view for the crew on the ND page if the selected runway is too short. ROP gives reversible aural and visual indications if the current aircraft braking performances are not sufficient to stop on the runway.

FMS: Flight Management System
KCCU: Keyboard and Cursor Control Unit

BRAKE TO VACATE DATA

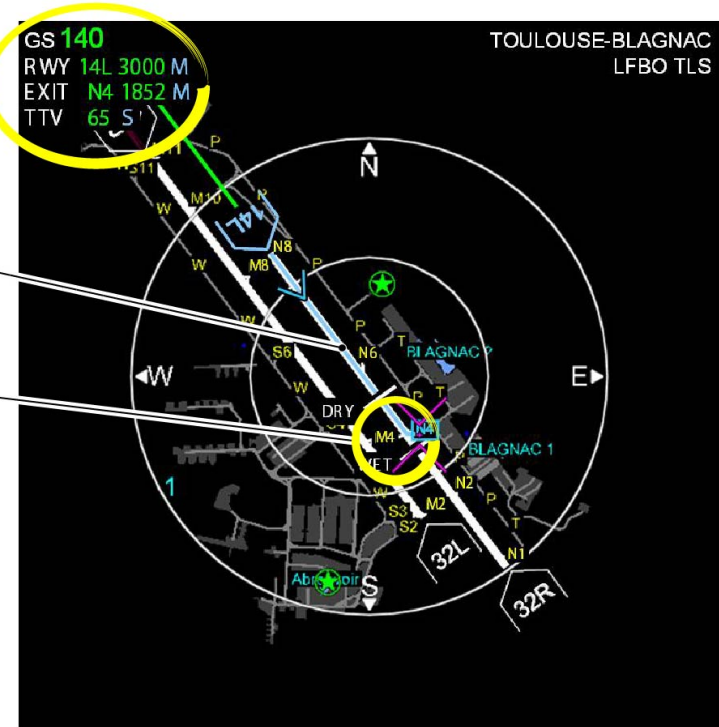

BLUE LINE INDICATING AIRCRAFT PATH TO SELECTED EXIT

RUNWAY EXIT SELECTION

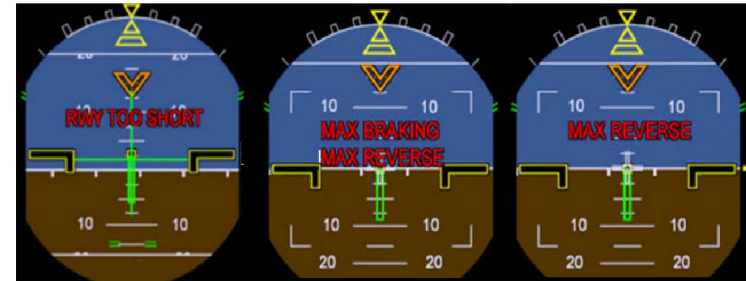
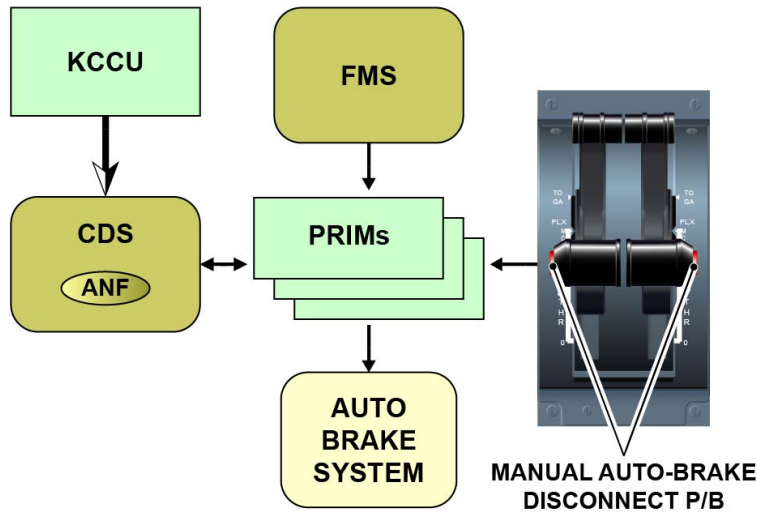

BRAKE TO VACATE

V1813401 - V01T0M0 - VM32DDNORMB3001

NORMAL BRAKING SYSTEM DESCRIPTION (3)

Remote Braking Control Unit Logics

The RBCUs 1 and 2 control and monitor the elements of each wheel group for redundancy purposes. Each selector valve is controlled by the two RBCUs. Each servo valve is also controlled by the two RBCUs.

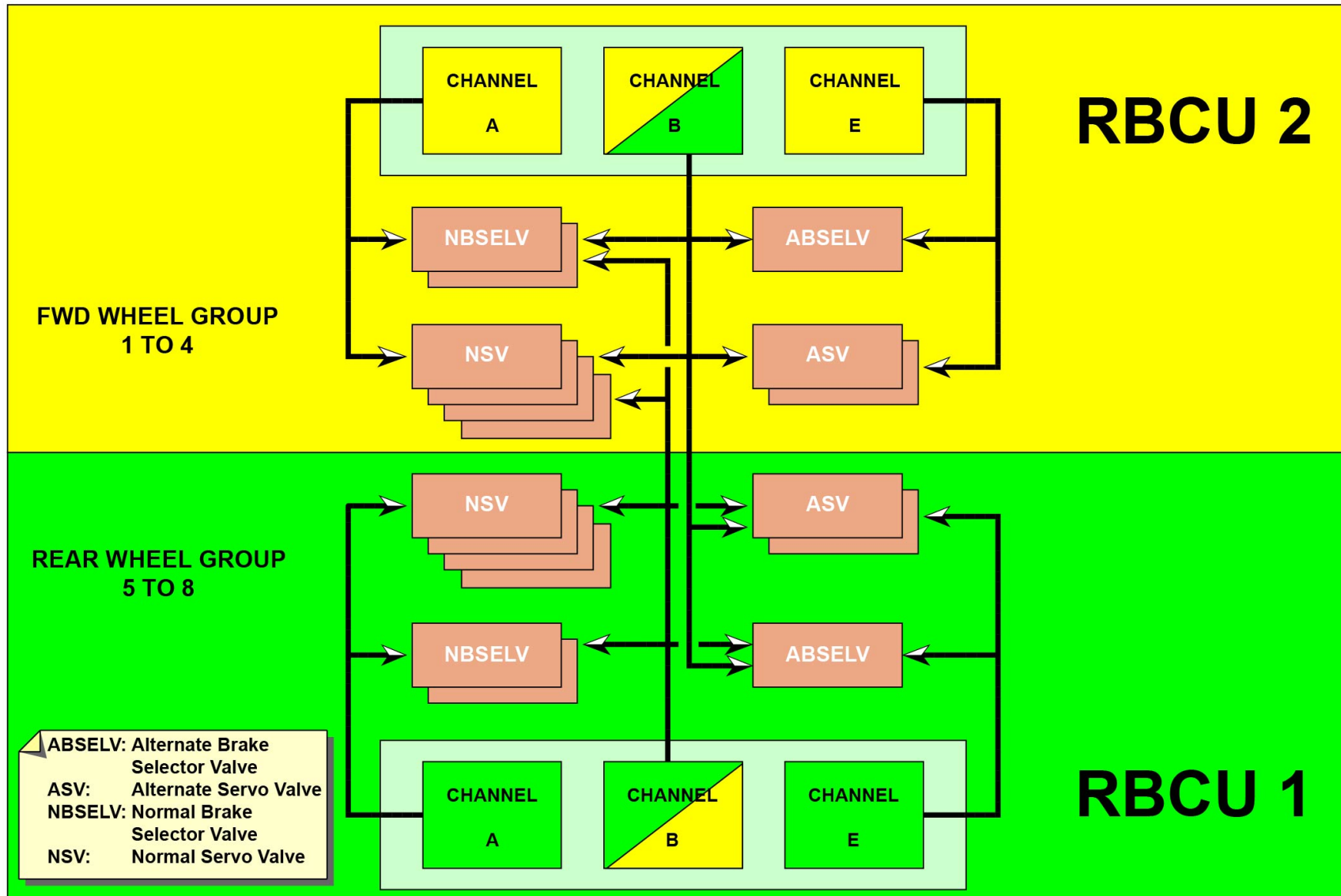

REMOTE BRAKING CONTROL UNIT LOGICS

V1813401 - V01T0M0 - VM32DDNORMB3001

ALTERNATE AND EMERGENCY BRAKING SYSTEMS DESCRIPTION (3)

Alternate and Emergency Modes Description

If a failure occurs in the normal braking or if the HP system is not available, the alternate braking is used. The alternate mode will replace the normal mode automatically. The alternate mode has two operating modes: Alternate braking with or without anti-skid. The source of pressure is the accumulator.

This mode has the same manual and automatic operation modes and the same anti-skid protection as the normal braking system.

The Braking Control System (BCS) application receives signals from the Brake Pedal Transmitter Unit (BPTU) or the auto brake system and calculates command signals. The CPIOMs send these signals to the Remote Braking Control Units (RBCUs).

The RBCUs supply 28 VDC power and the CPIOMs supply a ground signal (through relays) to open the Alternate Brake Selector Valves (ABSELVs). The RBCUs also send signals to control and adjust the Alternate Servo Valves (ASVs). The ASV supplies pressure to a pair of brakes (max of 3000 psi).

The RBCUs control and monitor the system with full authority if there is a dual braking side failure or an AFDX network failure. Only pedal braking is then available (inputs from Captain's BPTU). Anti-skid protection is also available.

The brake pedals signal is sent by the Captain's BPTU. The BPTU transmits the orders in proportion to the pedal travel only to the RBCUs. When the brake pedals are pushed, then the RBCUs supply 28 VDC power and the CAPT's BPTU supplies a ground signal to open the ABSELV. The RBCUs also send signals to control and adjust the ASVs. In alternate braking without anti-skid, the pressure is limited (1131 psi). Auto braking, retraction braking and the anti-skid protection are not available. Control with the CPIOMs and/or the RBCUs is the same as for alternate braking with anti-skid.

In emergency mode, the pressure is also limited (1131 psi) to prevent tire burst. Only pedal braking is available with the RBCU.

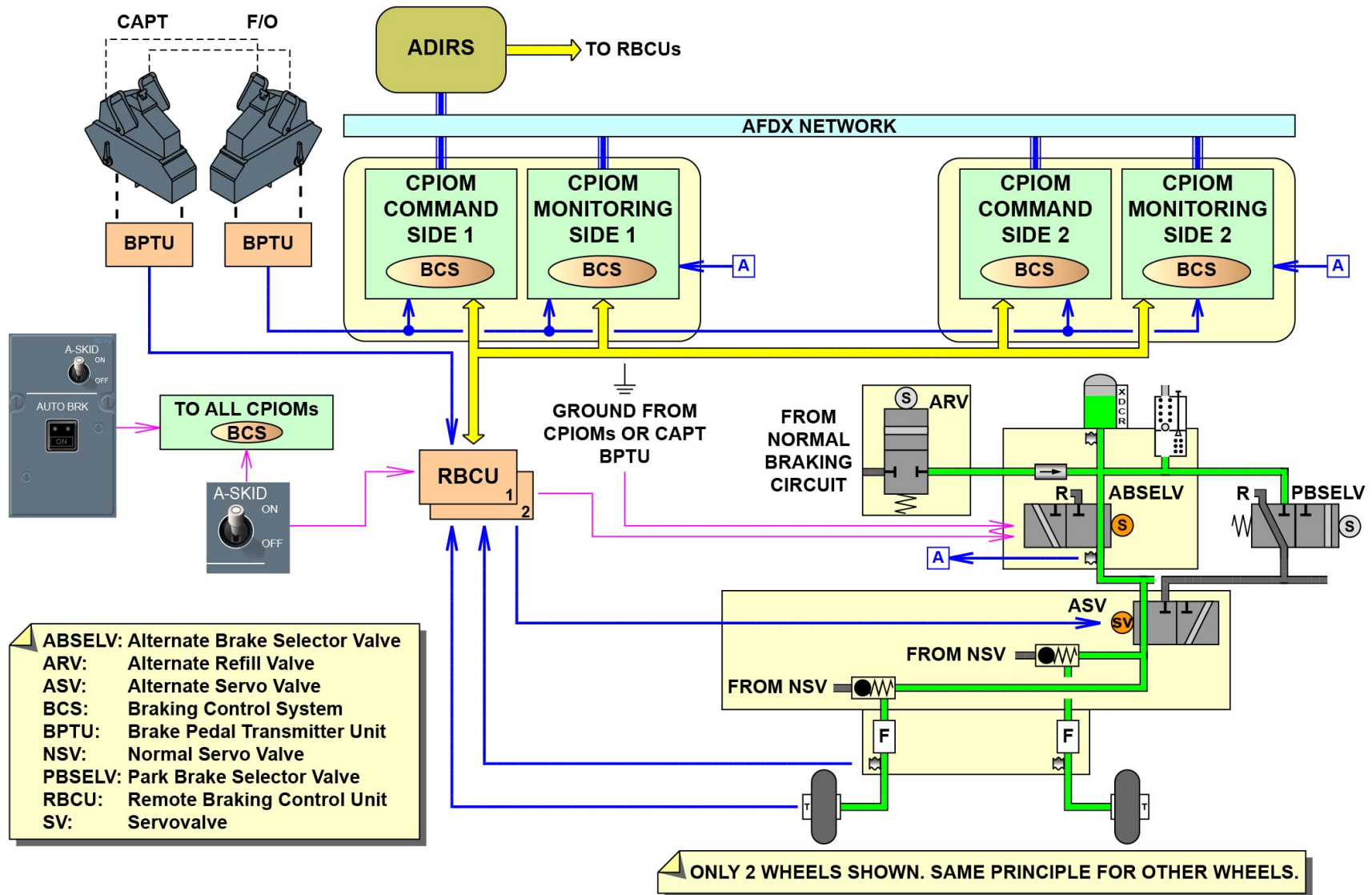

ALTERNATE AND EMERGENCY MODES DESCRIPTION

ALTERNATE AND EMERGENCY BRAKING SYSTEMS DESCRIPTION (3)**Accumulator**

Each alternate braking accumulator is of the maintenance-free helium pre-charge type. Pressure is monitored by the RBCUs and shown on the center pedestal and the CDS. Quantities are monitored by the RBCUs for the CDS.

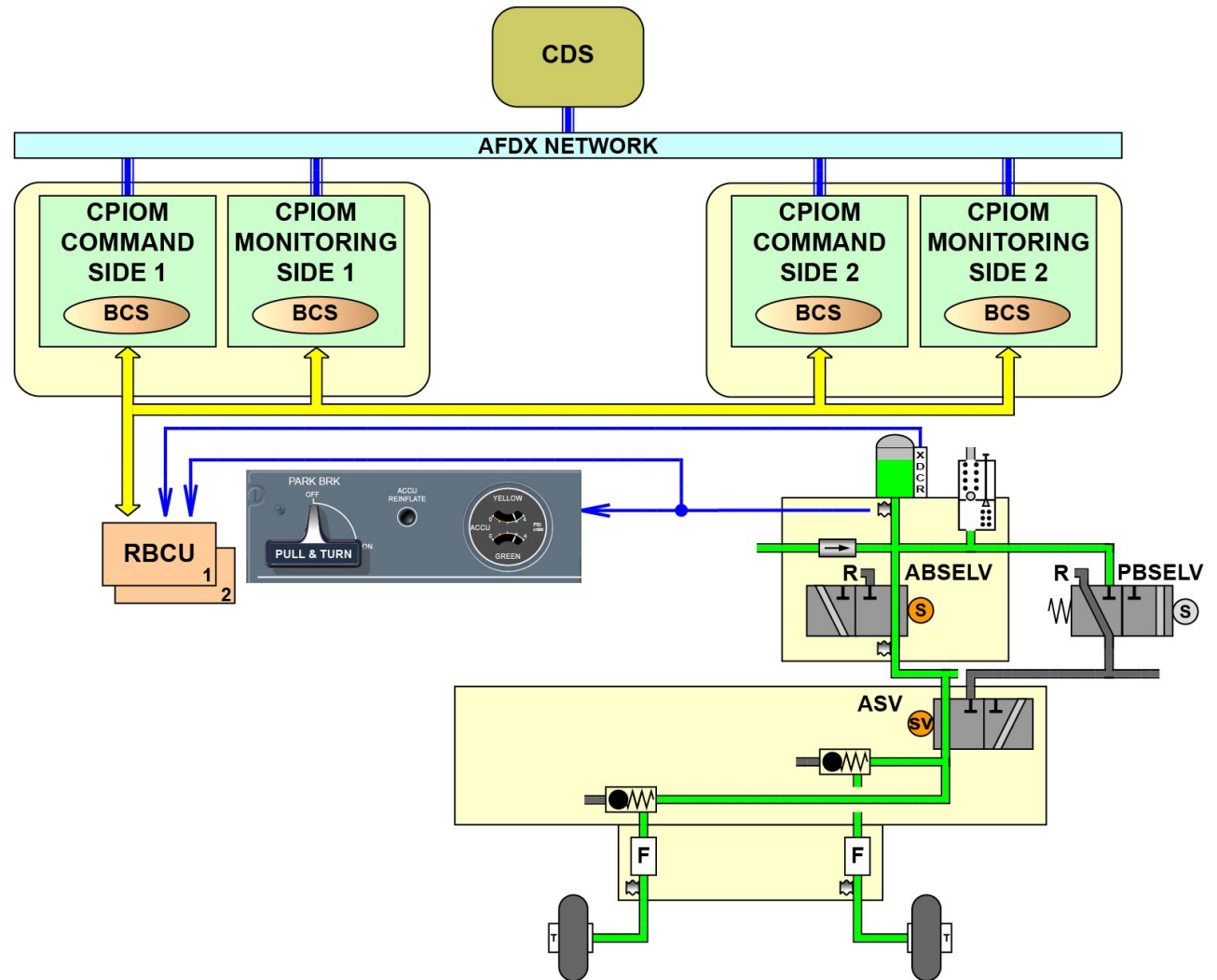

ACCUMULATOR

V1813401 - V01T0M0 - VM32D8ALTBK3001

PARKING AND ULTIMATE BRAKING SYSTEMS DESCRIPTION (3)

Parking / Ultimate Braking

The system receives its hydraulic power supply from the alternate braking accumulators. The accumulators have a capacity that can hold the pressure for a minimum of 12 hours. They supply the necessary pressure to the parking brake system before the engine start and run-up.

To operate the parking brake mode, a discrete signal of 28 VDC (from EMER HOT BUS 1 and 2) is sent from the park-brake handle in the cockpit, to open the Park Brake Selector Valves (PBSELVs). Full accumulator pressure is sent to the brakes.

Each PBSELV is energized with 28 VDC (from EMER HOT BUS 1 and 2). The PBSELV is an electrically controlled valve, thus when it is set (ON or OFF), no more electrical power is necessary to keep the PBSELV in position.

When the parking brake handle is set to "ON", the PBSELV switch sends a signal to the RBCUs for the CDS and the parking brake light on the Nose Landing Gear (NLG) steering disconnect panel.

The ultimate braking mode is the parking brake mode when the aircraft moves (taxi, landing and Rejected Take Off (RTO)). It becomes "ON" when the pilots move the parking brake handle to "ON". This mode has no anti-skid protection.

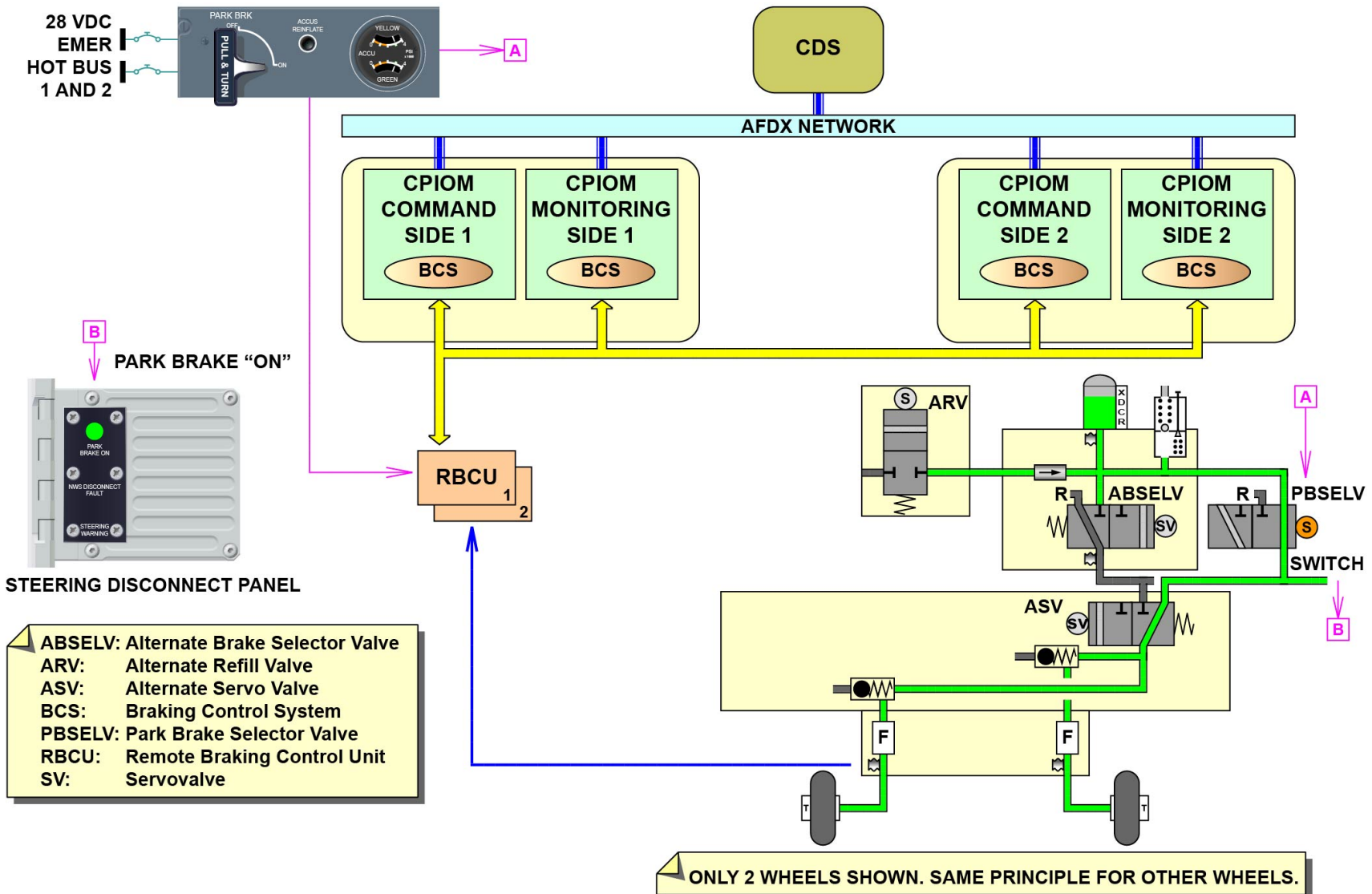

ABSELV: Alternate Brake Selector Valve
ARV: Alternate Refill Valve
ASV: Alternate Servo Valve
BCS: Braking Control System
PBSELV: Park Brake Selector Valve
RBCU: Remote Braking Control Unit
SV: Servo Valve

PARKING / ULTIMATE BRAKING

V1813401 - V01T0M0 - VM32D9PKBRK3001

BRAKING SYSTEMS MAINTENANCE (2/3)

Wheel Change

The function of this maintenance module is to give guidelines during a wheel change and brake bleeding task. It also shows the important steps to do during a brake deactivation.

During an Main Landing Gear (MLG) wheel change, a small brake pressure is applied. From the OMT, an interactive mode through a special ATA32 function menu sends hydraulic pressure to the brakes without operation of the pedals.

AIRCRAFT CONTROL DOMAIN

SPECIFIC FUNCTIONS

Interactive Mode

Selected System

ATA:

Sub-ATA:

System:

Selected Operation:

Interactive BITE : Function Selection

Please make sure you have performed the following action:

- Select Green Hydraulic pressure ON
- Select Yellow Hydraulic pressure ON
- Select Park Brake OFF, MAKE SURE THAT WHEEL CHOCKS ARE IN POSITION
- Make sure Antiskid Switch ON

WHEEL CHANGE

V1813401 - V01T0M0 - VM32MIBRAKE3001

BRAKING SYSTEMS MAINTENANCE (2/3)

Brake Unit Bleeding and Deactivation

During a braking-system bleeding procedure, a small brake pressure is applied. From the OMT, an interactive mode through a special ATA32 function menu sends hydraulic pressure to the brakes without operation of the pedals. This menu is the same as for a wheel change. The pressure is small, to make sure that the hydraulic fuse (safety valve) does not close if the brake bleeding valve stays in the full open position during the bleeding procedure.

In-service experience shows that important steps are not obeyed during brake deactivation. This can cause in-service issues and delays. Before the coupling is disconnected, it is mandatory to set the parking brake lever to the "OFF" position. Bleeding of the deactivated brake unit is also mandatory. A leak check is necessary to make sure that the brake quick-disconnect coupling is closed.

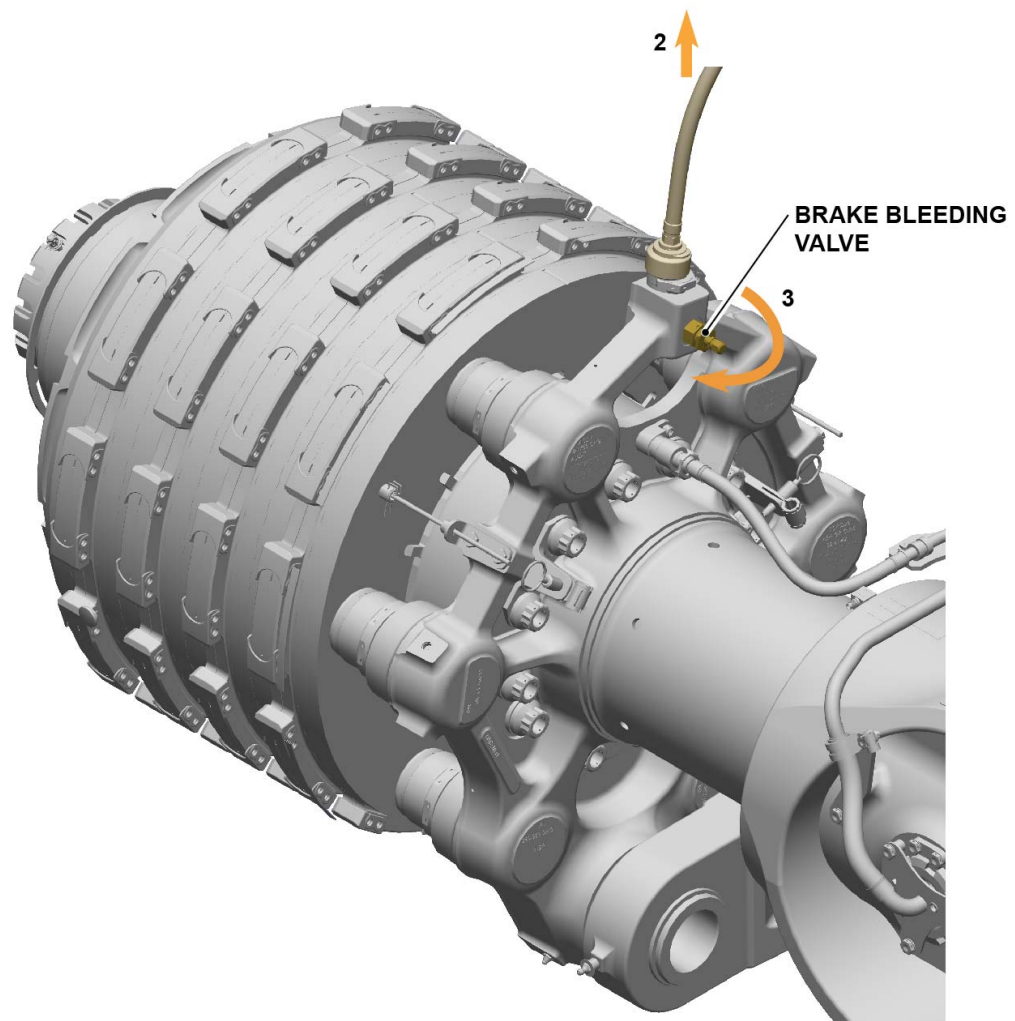

- BRAKE DEACTIVATION MAIN STEPS ORDER**
1. PARKING BRAKE LEVER "OFF"
 2. COUPLING DISCONNECTION
 3. BRAKE BLEEDING
 4. LEAK CHECK

BRAKE UNIT BLEEDING AND DEACTIVATION

V1813401 - V01T0M0 - VM32MIBRAKE3001

LANDING GEAR MANAGEMENT SYSTEM DESCRIPTION (2/3)

Brake Temperature Monitoring System

The brake temperature system measures the temperature at each brake unit and sends this data to the CDS. The main objectives are:

- To prevent take-off with a hot brake
- To prevent landing gear retraction with a hot brake, which can cause a bay fire.
- To monitor residual braking.

A Brake Temperature Sensor (BTS) is installed in each brake unit. It supplies an output voltage in proportion to the temperature. These outputs are sent independently to a Brake Temperature Compensation Module (BTCM). The BTCM (one for each bogie) senses the temperature and sends an analog signal to the Wheel Remote Data Concentrator (WRDC). The WRDCs transmit temperature data through the Remote Braking Control Unit (RBCU) to the CPIOMs (Landing Gear Management System (LGMS) application). The LGMS uses the brake temperature data to give brake temperature data and alerts. The SD pages give brake temperature data to the crew by the indication on the related wheel page.

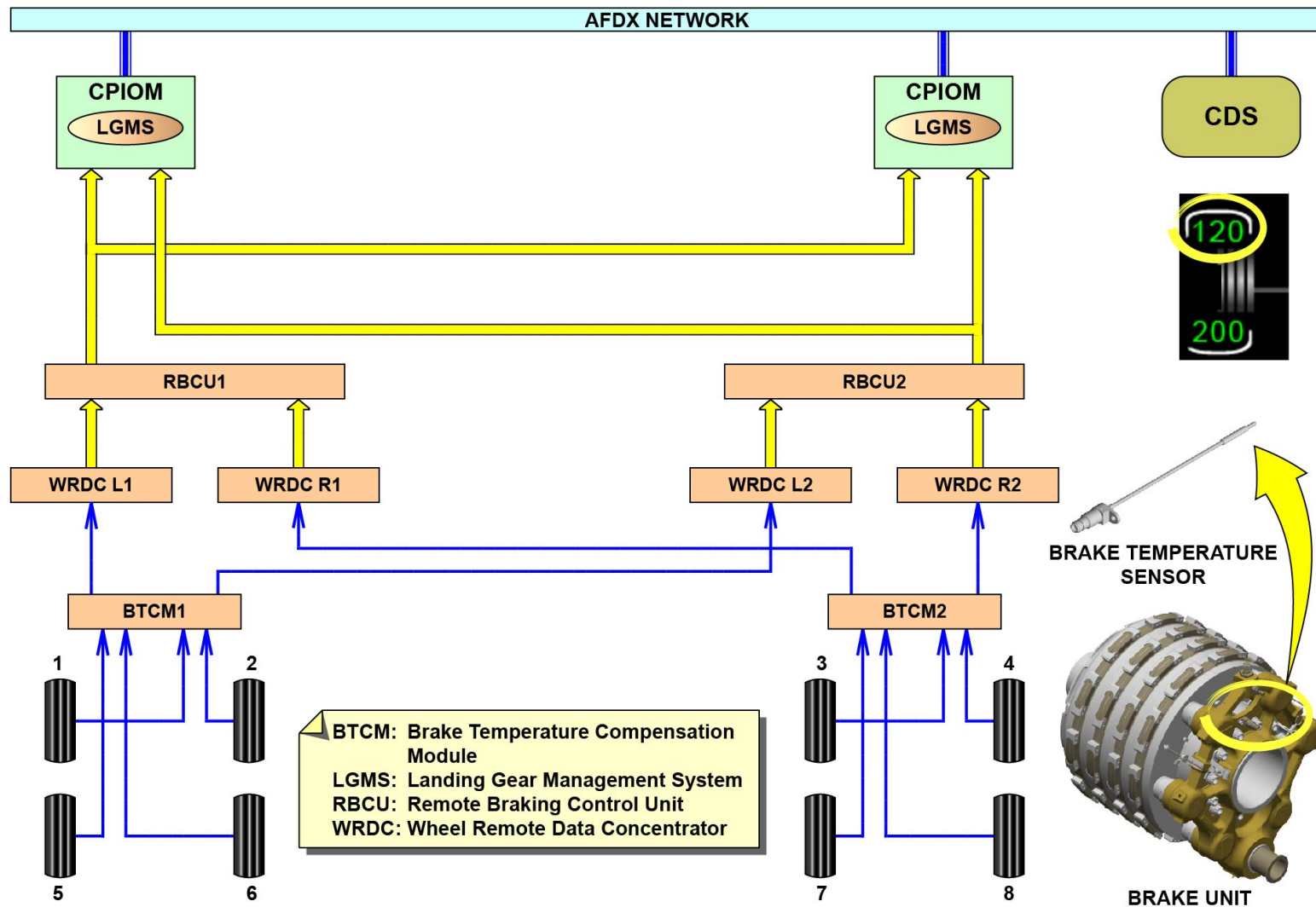

BRAKE TEMPERATURE MONITORING SYSTEM

V1813401 - V01T0M0 - VM32DCL.GMS03001

LANDING GEAR MANAGEMENT SYSTEM DESCRIPTION (2/3)

Tire Pressure Indicating System

The Tire Pressure Indicating System (TPIS) measures and monitors the tire pressure. Its function is to help the maintenance personnel do the maintenance task and to prevent a take-off with low pressure.

The tire pressure is sensed by a pressure sensor (attached on a pressure sensor holder on the wheel rim) and is changed into wireless signals. Signals are transmitted to the rotating interface unit where they are digitized and then sent to the static interface unit in the wheel hub (wireless signals).

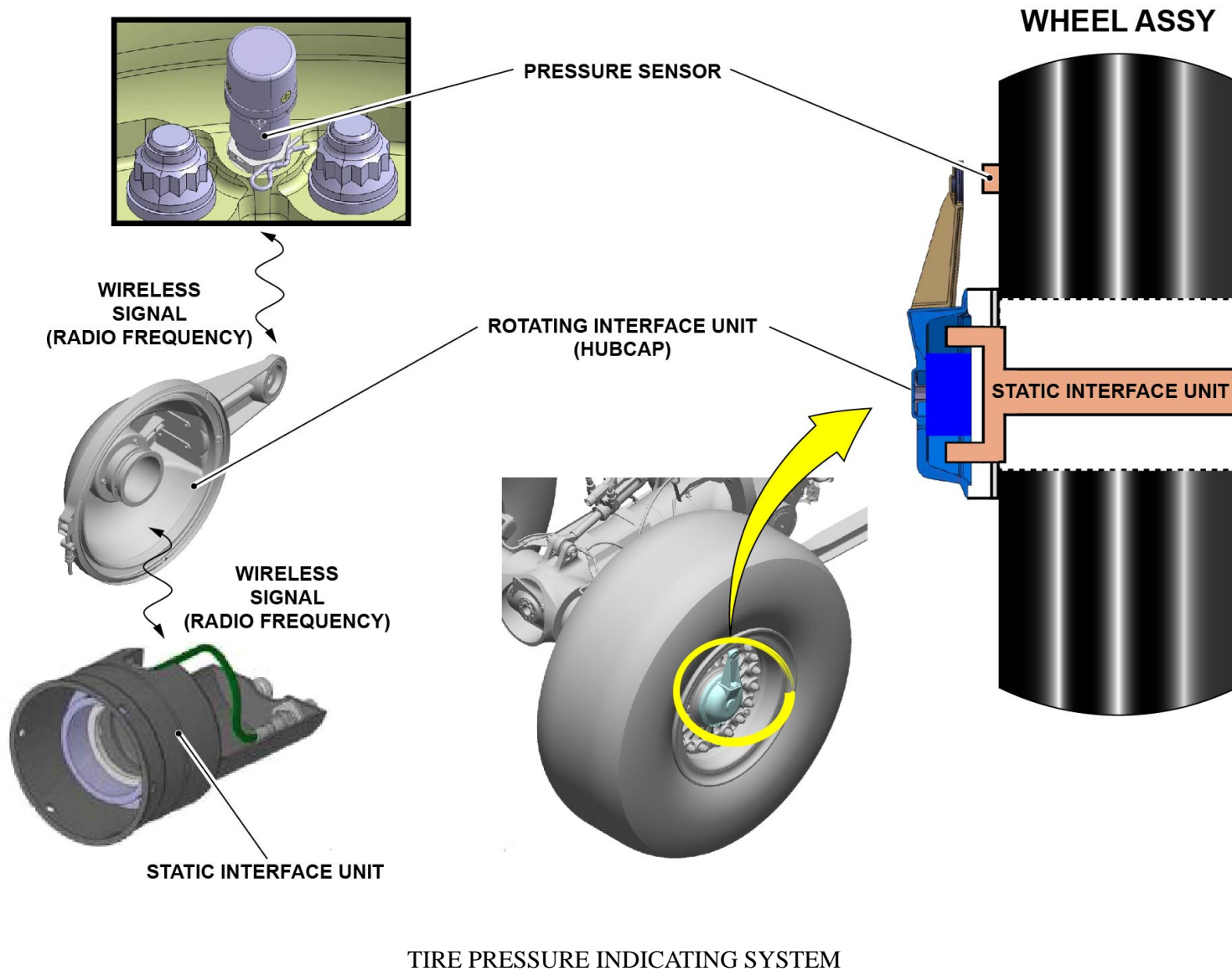

V1813401 - V01T0M0 - VM32DCL.GMS03001

LANDING GEAR MANAGEMENT SYSTEM DESCRIPTION (2/3)

Tire Pressure Indicating System

From each static interface unit, data are sent to the WRDC, which changes the signals into ARINC 429 format. Data are then sent to the RBCU which operates as a gateway and transmits the data to the CPIOMs (LGMS application).

If the CPIOMs identify that the tire pressure is unsatisfactory, they will give and transmit applicable warnings. A warning is started when the tire pressure value for one or more wheels is too low or when the difference in pressure values for two tires on the same axle is too large.

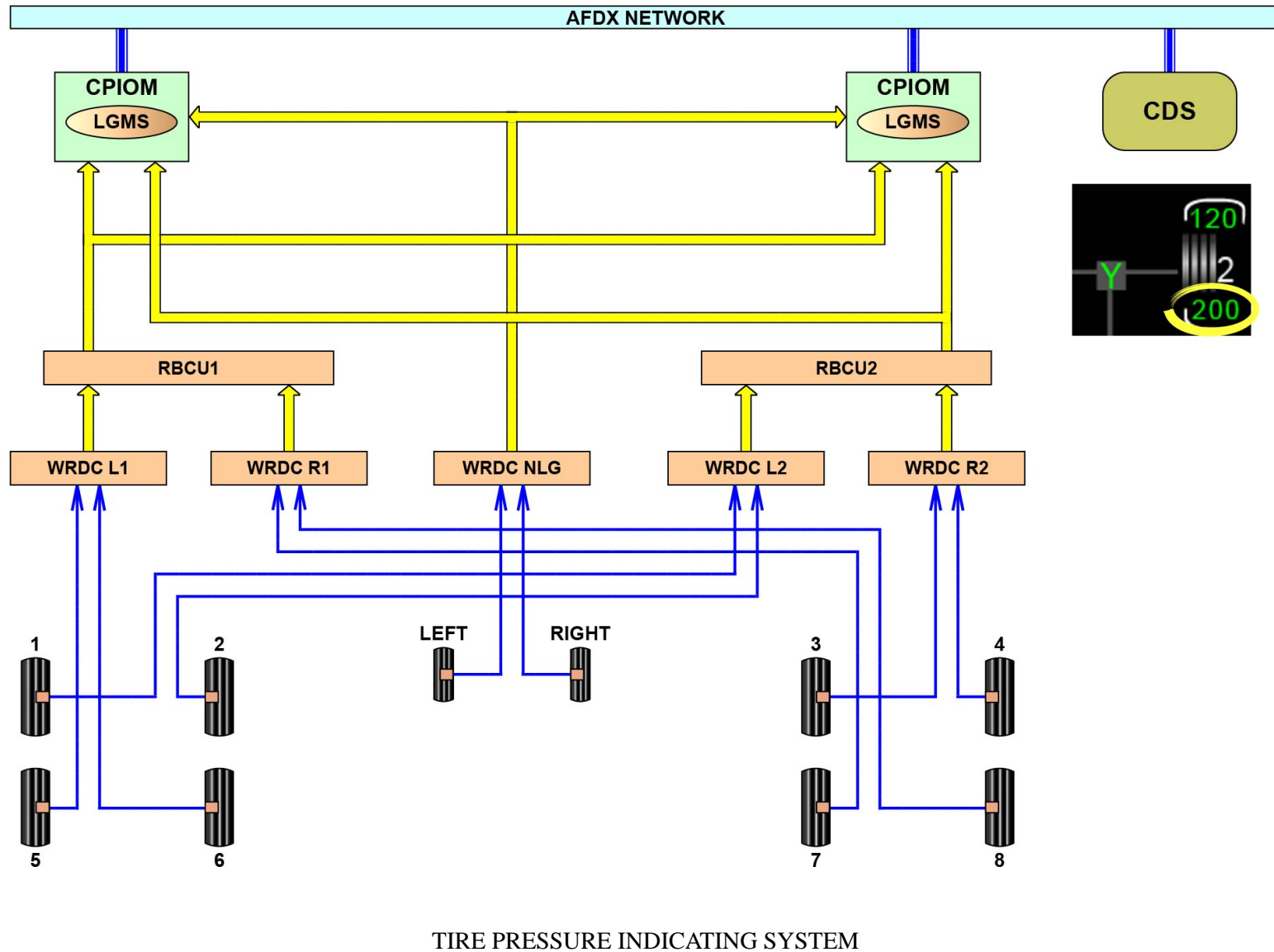

V1813401 - V01T0M0 - VM32DCLGMS03001

TIRE PRESSURE INDICATING SYSTEM

LANDING GEAR MANAGEMENT SYSTEM DESCRIPTION (2/3)

Brake Cooling Fan (option)

The function of the Brake Cooling Fan (BCF) is to get faster aircraft turn-around times. The BCF cools the brakes more quickly than natural convection.

The LGMS controls the Solid State Power Controllers (SSPCs) which supply power to the brake cooling-fan motors, through On/Off orders sent through the AFDX network. The Landing Gear Extension and Retraction System (LGERS) (Weight on wheels) interfaces with the BCF function. The aircraft must be sensed to be on the ground to use the BCF. The Propulsion Control System (PCS) also interfaces with the BCF function. Cooling fan operation is prevented during an engine high-thrust condition in order to load shed the electrical supply.

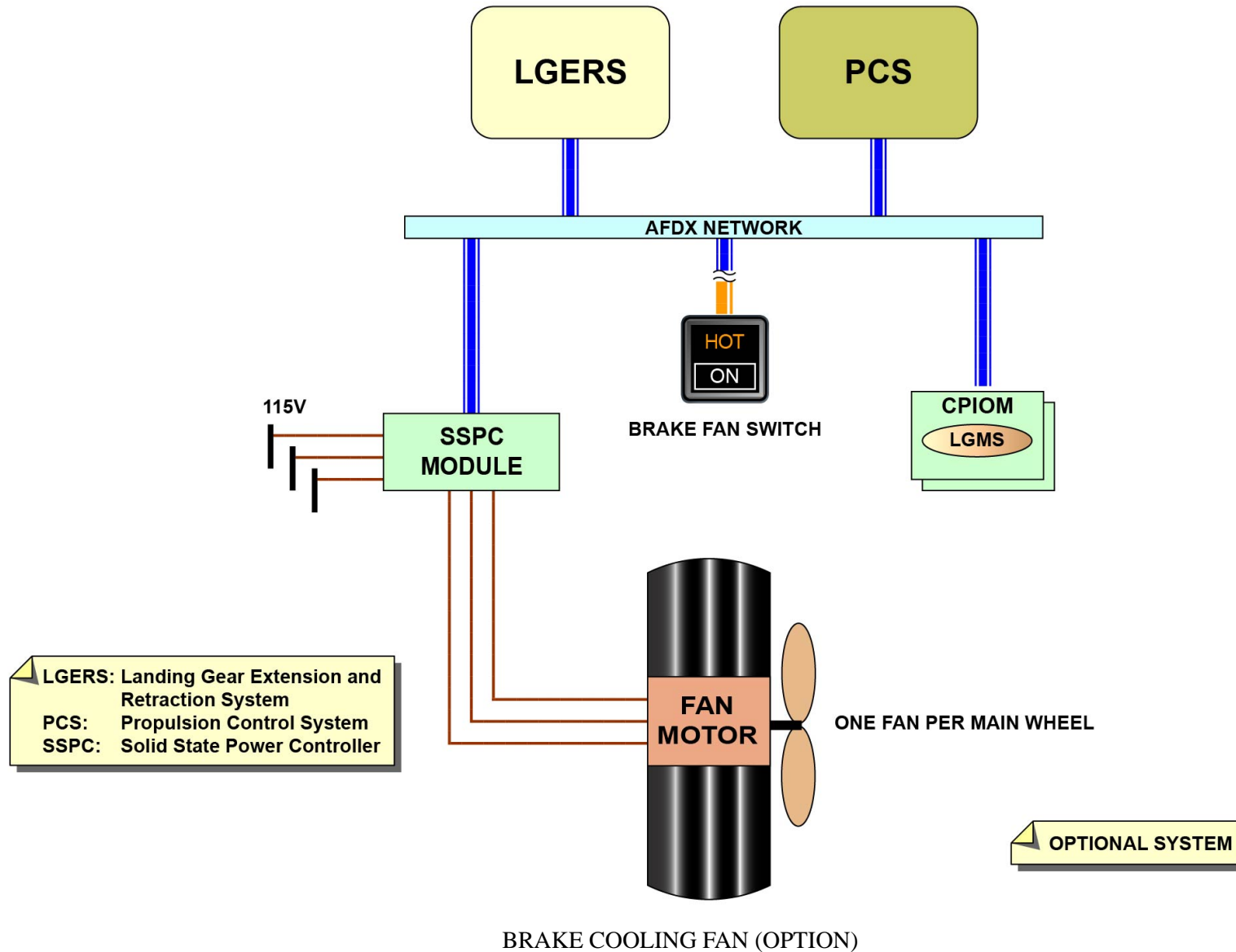

V1813401 - V01T0M0 - VM32DCLGMS03001

BRAKING SYSTEM CONTROL AND INDICATING (2)

Braking System - General (2)

The controls used to operate the brakes are the pedals, Auto brake P/B switch, Anti-skid switch and the Parking Brake handle.

There is also an Accumulator Re inflate P/B switch on the center pedestal. An optional Brakes cooling fan P/B switch is located on the main instrument panel.

The indications are on ECAM wheel page, the Lower part of the PFD (Slat Flap Limitation Memo), on the center pedestal and on the Steering Disconnect Panel of the NLG.

Brake Pedals (2)

The pedals are used in manual braking. This function is available in normal, alternate and emergency modes.

The pedals are mechanically connected between them. When the left pedal is operated, the left wheels are braked (1, 2, 5 and 6). In the same way when the right pedal is operated, the right wheels are braked (3, 4, 7 and 8).

The forward wheel group (1 to 4) and the aft wheel group (5 to 8) operate independently: Yellow hydraulic HP / accumulator supply for the forward and green hydraulic HP / accumulator supply for the aft. Each group can operate in a different mode. For example, the forward group in normal mode and the aft group in alternate with anti-skid mode.

The Wheel page provides information about the wheels and brakes, the green and yellow hydraulic supply, the braking mode status, accumulators availability and the BRAKES CTL channels status (if MORE key is depressed).

When the brake pedals are used, the average pressure sent to the L/H and R/H brakes is indicated by the vertical bars on the WHEEL page.

On the lower part of the PFD, there is no indication about brake pressure.

Anti-Skid Switch (2)

When the Anti-skid switch is set to ON, the anti-skid function is available in normal braking or alternate braking modes.

On the ECAM Wheel page, NORM or ALTN legend are normally green (or amber if the corresponding mode is inoperative).

When the Anti-skid switch is set to OFF, the Anti-skid function is deactivated and all braking groups are in Emergency mode. A-SKID amber legend is displayed on the Wheel page.

On the ECAM Wheel page, EMER legend is green (or amber if the emergency mode is inoperative).

Parking Brake Handle and ACCUS REINFLATE P/Bsw (2)

The Parking Brake handle can activate two different modes depending on the A/C conditions: parking or ultimate.

Parking brake is used when the A/C is at the gate or during taxi phases. Ultimate braking mode is used when the A/C is moving and all the other braking modes are not available.

When the Parking Brake handle is set to ON, brakes 1 to 4 are supplied by the yellow accumulator and the brakes 5 to 8 by the green accumulator. The pressure sent to the brakes is the available accumulators pressure. Pressure can be monitored on the G & Ya Accumulator Pressure Indicator (center pedestal) and on the WHEEL page.

A Green & Yellow Accu Pressure Indicator upper needle shows the pressure in the Yellow Brake Accumulator and the lowest needle the pressure in the Green Brake Accumulator.

The average pressure sent to the L/H and R/H brakes is indicated by the vertical bars on the WHEEL page.

When the parking brake is applied, a MEMO message is shown on the memo page and the lower part of the PFD.

A Park Brake light is also illuminated on the NLG Steering Disconnect Panel.

An 'ACCUS REINFLATE' P/B switch is located on the center pedestal. It is used to recharge and re-pressurize the accumulators from the green and yellow HP hydraulic system in case of accumulator low pressure. A Green & Yellow Accu Pressure Indicator upper needle shows the pressure in the Yellow Brake Accumulator and the lowest needle the pressure in the Green Brake Accumulator.

Brakes and Wheels Indications (2)

On the ECAM WHEEL page, at the upper part of each wheel indication appears the value of the brake temperature. The indication appears in green color until the brake temperature reaches 300 degrees. From this value, it is considered to be in a brake overheat condition and then it changes to amber color.

The highest temperature indication has an arc over the value. This arc is green under 300 degrees and amber above 300 degrees at the hottest brake.

If the brake cooling fan is installed, an Amber HOT overheat indication appears on the BRK FAN P/B switch.

By pressing the BRK FAN P/B switch all the brake fans are started.

By pressing the BRK FAN P/B switch a second time all the brake fans stop.

On the ECAM WHEEL page, at the lower part of each wheel indication appears the value of the tire pressure. The indication appears in green color when the tire pressure is within (programmable) limits. If not, the corresponding tire symbol is displayed in amber.

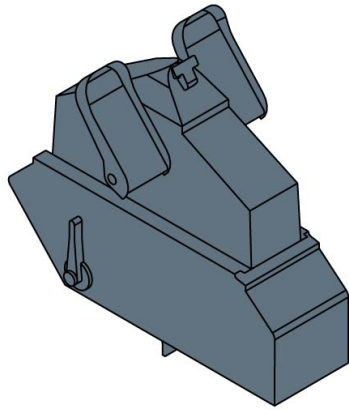

BRAKE PEDALS



AUTOBRAKE CONTROL PANEL



ECP

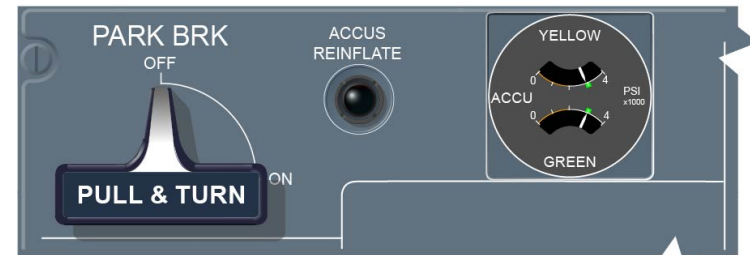
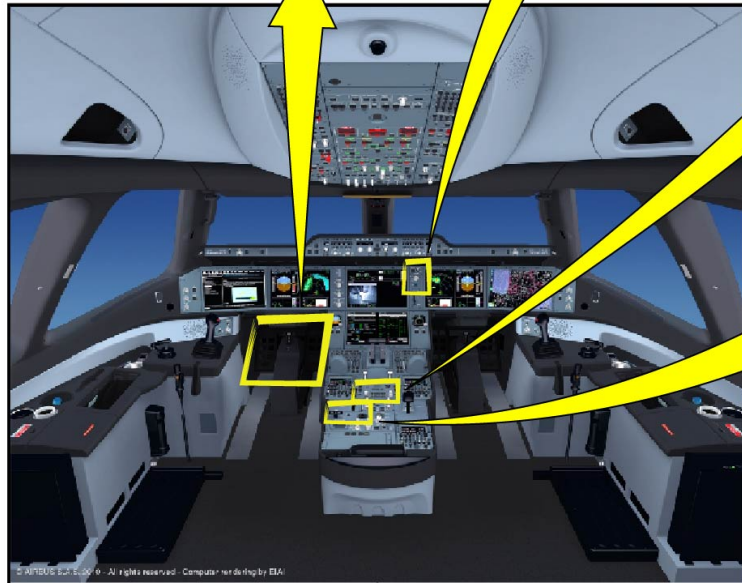

PARKING BRAKE CONTROL PANEL

ECP: ECAM Control Panel
ECAM: Electronic Centralized Aircraft Monitoring

BRAKING SYSTEM - GENERAL (2) ... BRAKES AND WHEELS INDICATIONS (2)

V1813401 - V01T0M0 - VM3213BRAKE2301

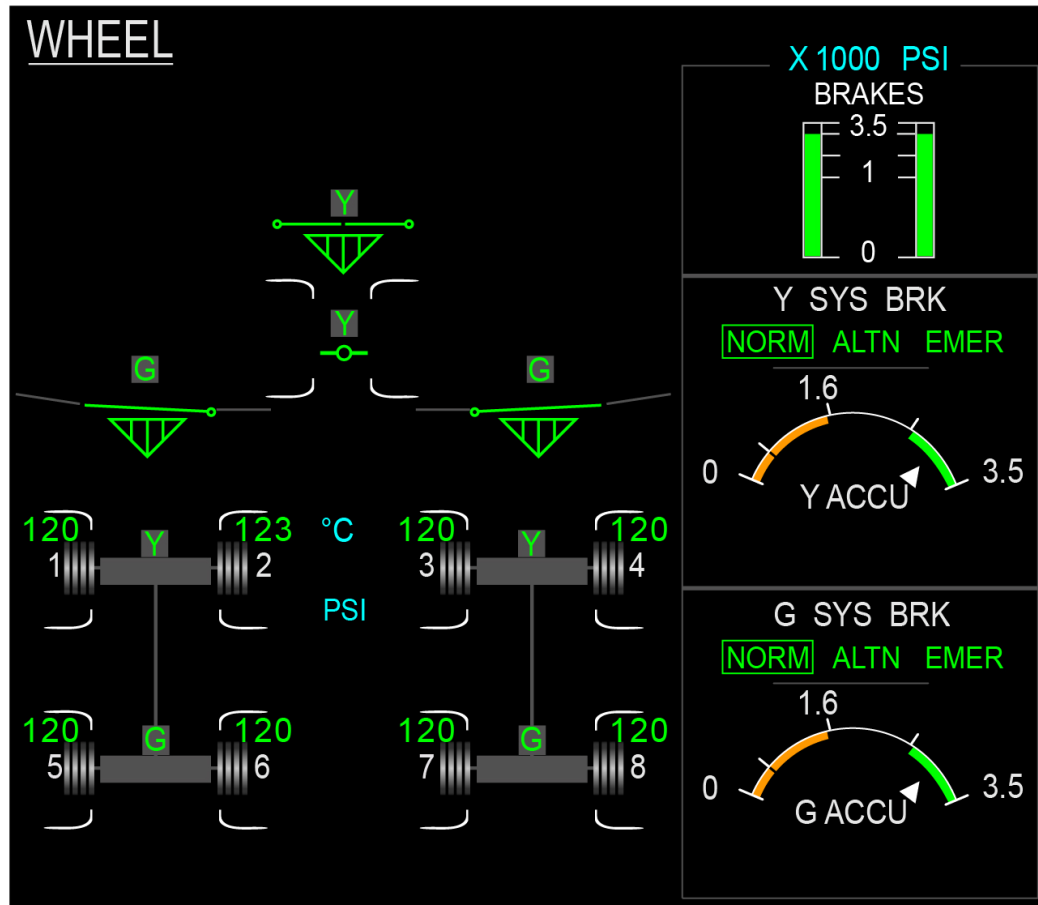

ECAM WHEEL PAGE

BRAKING SYSTEM - GENERAL (2) ... BRAKES AND WHEELS INDICATIONS (2)

V1813401 - V01T0M0 - VM3213BRAKE2301

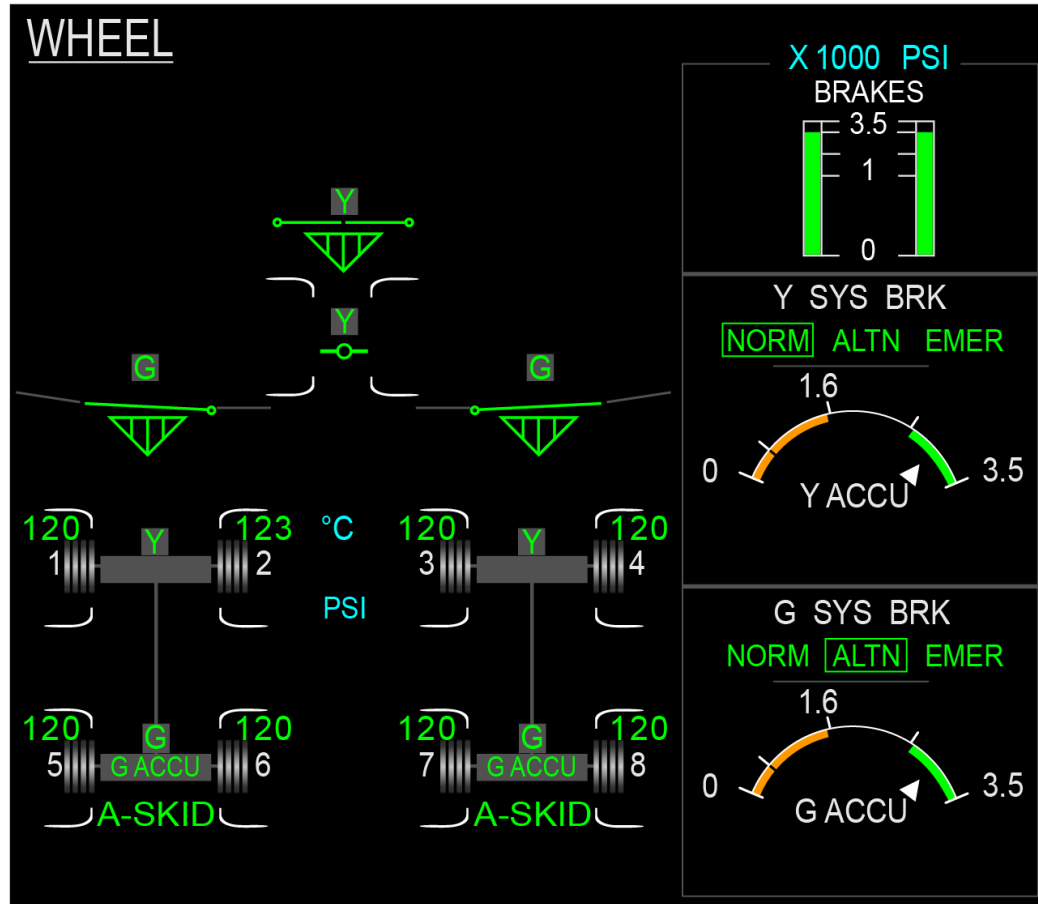

ECAM WHEEL PAGE

BRAKING SYSTEM - GENERAL (2) ... BRAKES AND WHEELS INDICATIONS (2)

V1813401 - V01T0M0 - VM3213BRAKE2301

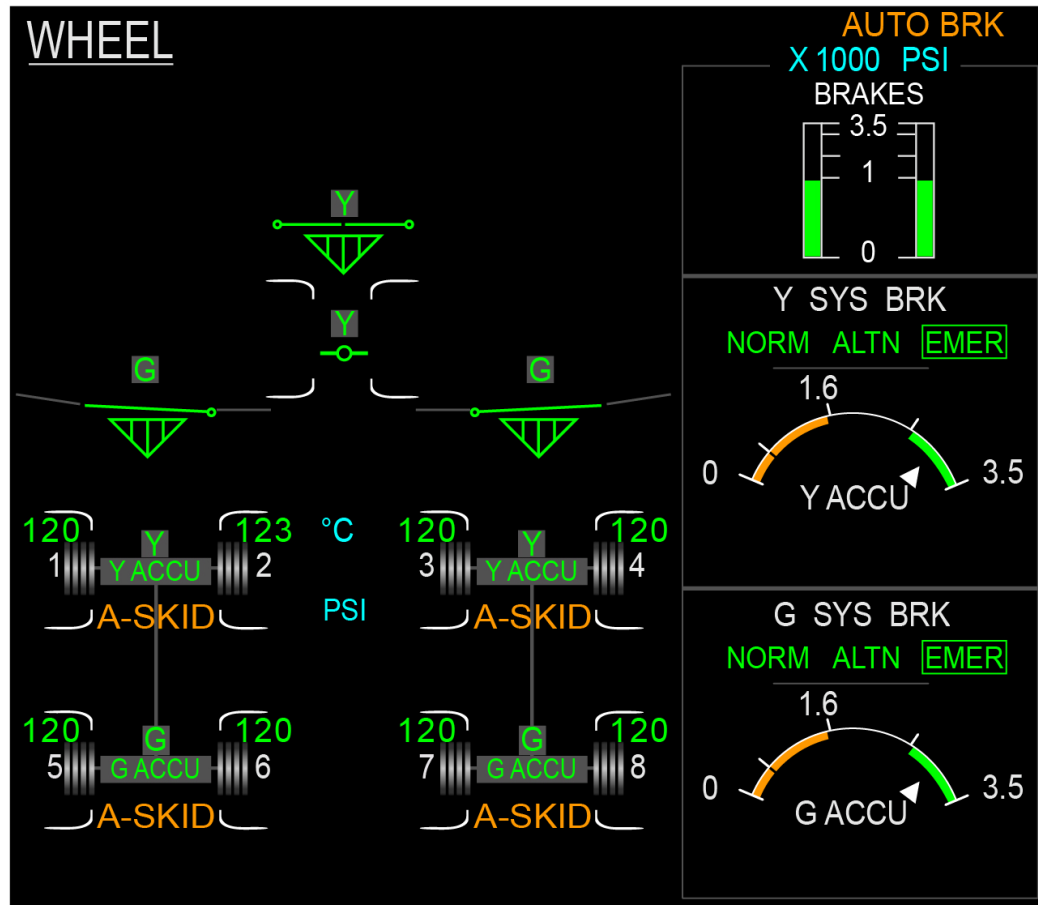

ECAM WHEEL PAGE

BRAKING SYSTEM - GENERAL (2) ... BRAKES AND WHEELS INDICATIONS (2)

V1813401 - V01T0M0 - VM3213BRAKE2301

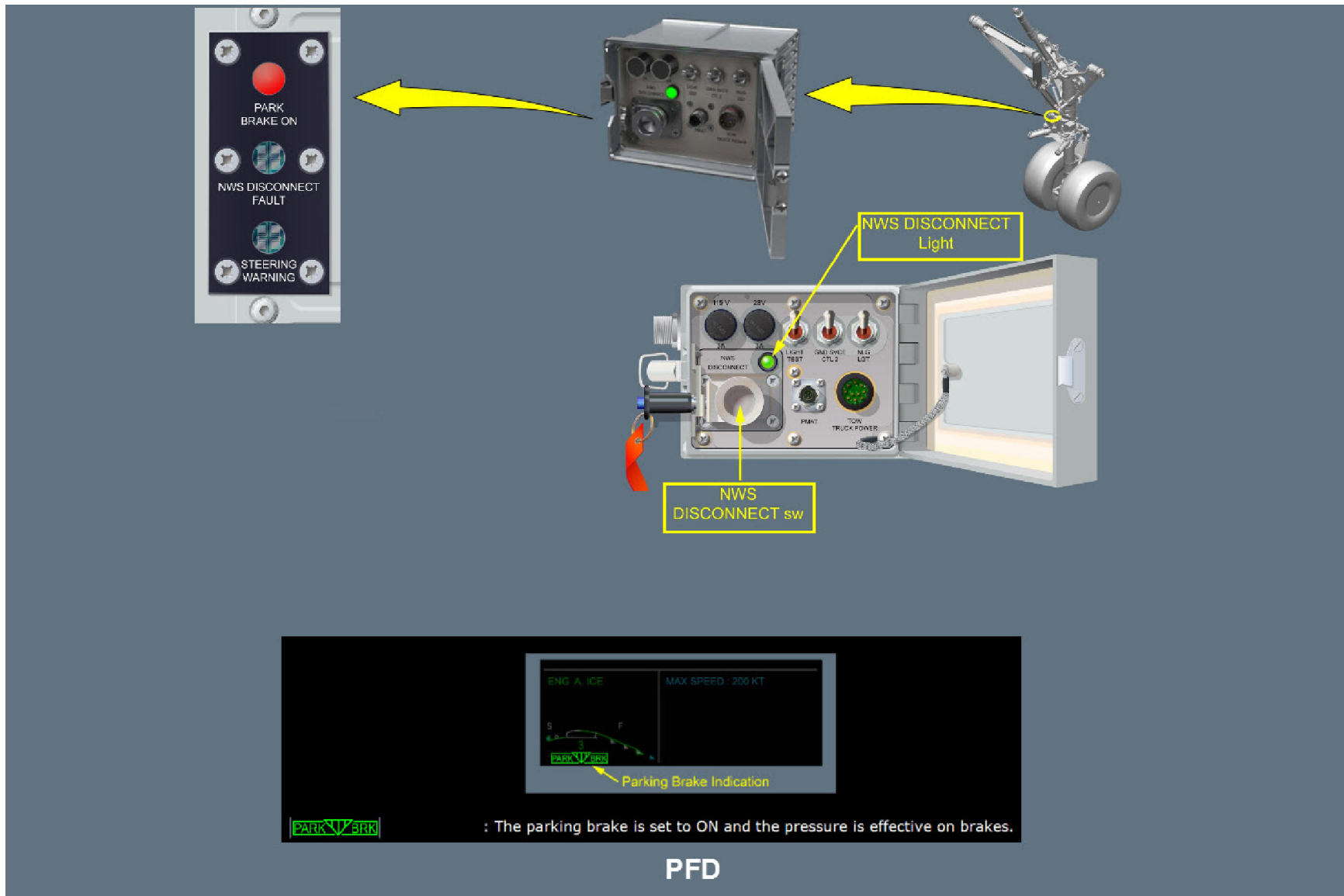

BRAKING SYSTEM - GENERAL (2) ... BRAKES AND WHEELS INDICATIONS (2)

V1813401 - V01T0M0 - VM3213BRAKE2301

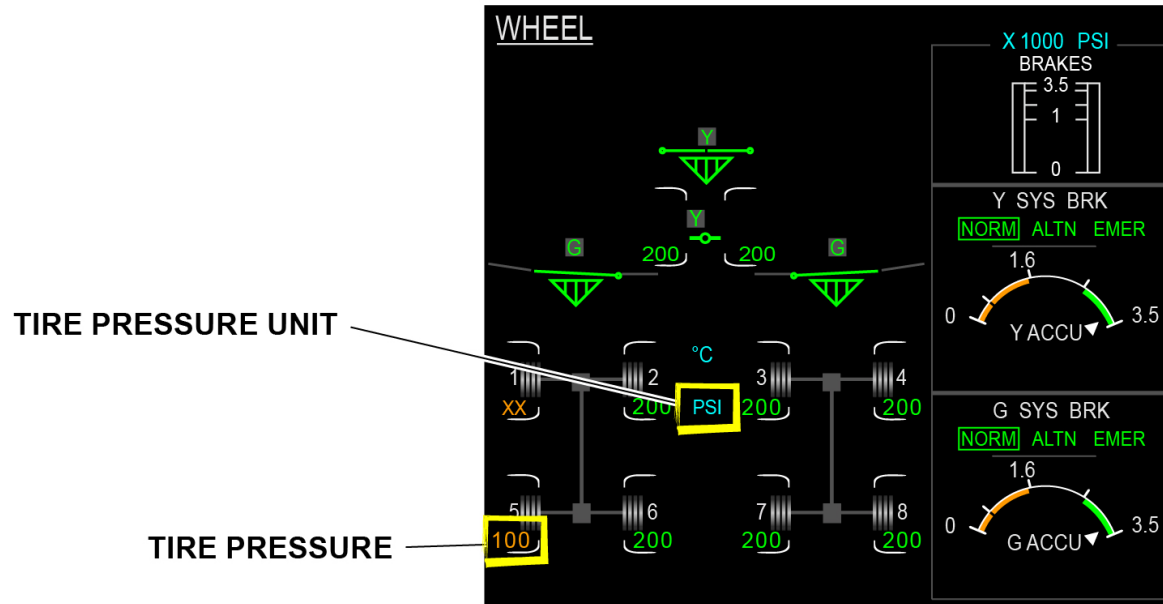

INDICATION	CONDITION
XX	TIRE PRESSURE DATA NOT AVAILABLE
100	TIRE PRESSURE IS LOW
200	TIRE PRESSURE IS SATISFACTORY

BRAKING SYSTEM - GENERAL (2) ... BRAKES AND WHEELS INDICATIONS (2)

V1813401 - V01T0M0 - VM3213BRAKE2301

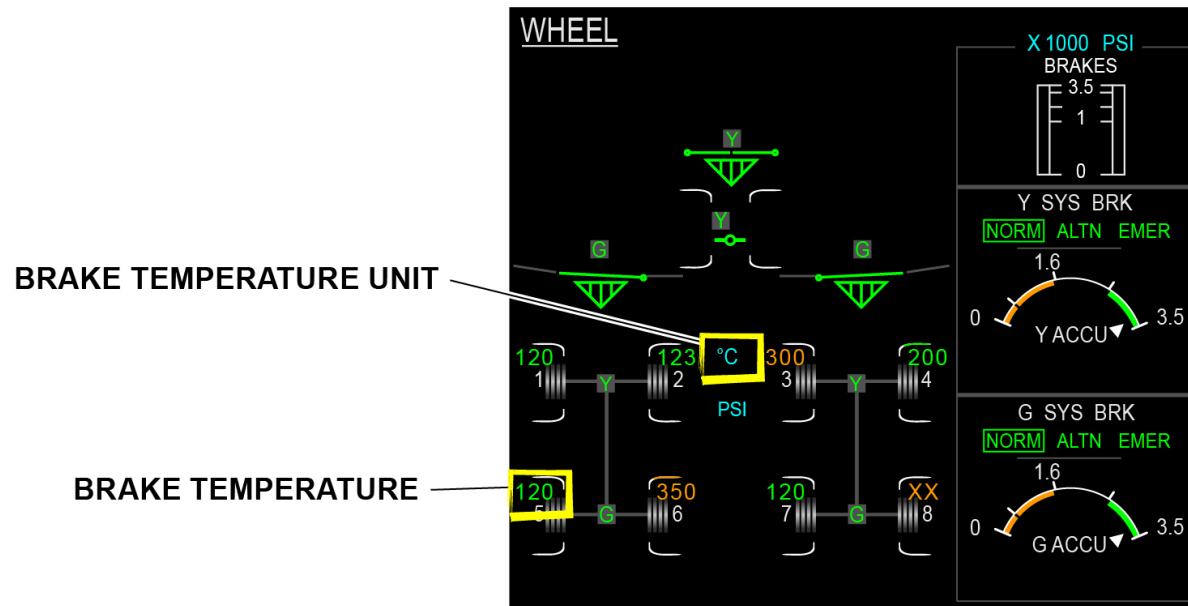

INDICATION	CONDITION
XX	BTMS INFORMATION NOT CORRECT OR LOSS OF BTMS DATA
350	HOTTEST BRAKE ON AIRCRAFT AND IN OVERHEAT ZONE
200	BRAKE TEMPERATURE IN OVERHEAT ZONE
100	HOTTEST BRAKE ON AIRCRAFT BUT NOT IN OVERHEAT ZONE
123	BRAKE TEMPERATURE IN DEGREES CELSIUS

BRAKING SYSTEM - GENERAL (2) ... BRAKES AND WHEELS INDICATIONS (2)

V1813401 - V01T0M0 - VM3213BRAKE2301

This Page Intentionally Left Blank

BRAKING SYSTEM CONTROL AND INDICATING (3)

Normal Braking with Brake Pedals and Auto-Brake at Landing (3)

The braking system on the A350 is divided in two different groups of brakes. Forward group for the brakes 1 to 4 and the aft group for the brakes 5 to 8.

For each group the braking mode is automatically selected to achieve the highest performance level by the system.

The normal mode is normally active if there is no system failure, HP hydraulic pressure available and the anti-skid switch is in the ON position. In the normal mode, the wheels are braked using HP hydraulic pressure from the two hydraulic systems and four different functions are available: pedal braking, autobrake, antiskid and in flight braking. Normal mode will be the first selected by the system if there is no failure and the hydraulic pressure is available.

The pedals input go to the Brake Pedal Transmitter Units (BPTU). The captain's and F/O's pedals are mechanically connected.

The L/H pedals control the pressure sent to the right wheel brakes (1, 2, 5 and 6). The R/H pedals control the pressure sent to the right wheel brakes (3, 4, 7 and 8).

The auto-brake is available if:

- A hydraulic system supply is pressurized,
- A ground spoiler extend signals is sent,
- AUTO brake P/B switch is selected
- The A/C is detected on the ground.
- Air Data and Inertial Reference System is available

When autobrake is engaged, the indication appears in the upper left corner of the PFD in blue color and change to green when the deceleration level is get.

The use of the brake pedals when the autobrake mode is engaged, will override it. By pushing the pedals over a predefined threshold, the autobrake mode will be disengaged.

The Autobrake can also be disengaged when we depress the engine throttle levers instinctive disconnect switches.

When the autobrake is active, the hydraulic supply goes to each Normal Brake Selector Valves (NBSELV). The NBSELVs are then commanded to open. The position of the NBSELVs is monitored by pressure transducers.

Based on the auto brake selection, the hydraulic pressure is then regulated by each Normal Braking Servo Valves (NBSV) and sent to each brake unit. The regulated pressure is monitored by pressure transducers.

Each wheel tachometer is used for the anti-skid protection.

When the autobrake is armed, the indication appears on the PFD in blue color and change to green when the deceleration level is reached.

When the pedals are depressed, the hydraulic supply goes to each Normal Brake Selector Valves (NBSELV). The NBSELVs are then commanded to open. The position of the NBSELVs is monitored by pressure transducers.

Based on the pedals deflection, the hydraulic pressure is then regulated by each Normal Braking Servo Valves (NBSV) and sent to each brake unit. The regulated pressure is monitored by pressure transducers.

Each wheel tachometer is used for the anti-skid protection.

On the ECAM Wheel page the indication shows which hydraulic system is supplying each L/G braking groups, the status of BRAKES CTL system 1 and 2 and the RBCUs (green or amber) when the MORE keys is depressed on the ECAM Control Panel.

The average pressure sent the L/H brakes (1, 2, 5, 6) and R/H brakes (3, 4, 7, 8) is indicated with moving vertical bars.

On the ECAM wheel page, the average pressure sent the L/H brakes (1, 2, 5, 6) and R/H brakes (3, 4, 7, 8) is indicated.

At the ECAM Wheel page, the hydraulic supply is indicated (in green or amber if no supply) for each wheel group.

Normal Braking with Auto-Brake at Take-Off (3)

The autobrake mode can be used during landing or during a rejected take off.

For takeoff, the RTO selection must be armed. The RTO is armed by pushing the AUTO brake P/B switch is selected.

When the RTO is selected but not in operation, the "BRK RTO" message is shown in blue on the PFD.

Once activated when the deceleration level is reached, the message changes to the green color.

The use of the brake pedals can disengage the autobrake mode. By pushing the pedals over a predefined threshold, the autobrake mode is disengaged.

The Autobrake can also be disengaged when we depress the engine throttle levers instinctive disconnect switches.

Alternate Braking Modes (3)

The braking system on the A350 is divided in two different groups of brakes. Forward group for the brakes 1 to 4 and the aft group for the brakes 5 to 8.

For each group the braking mode is automatically selected to achieve the highest performance level by the system.

For example, if a green NBSELV is faulty or the green HP hydraulic system fails, the normal mode will be unavailable for the aft braking group (brakes 5 to 8). The alternate braking mode automatically takes over for the aft group. The fwd group still operates in normal mode with the yellow HP system.

On the ECAM wheel page, the letter corresponding to the hydraulic system where the hydraulic pressure is lost appears in amber color. Alternate braking mode is possible with or without anti-skid. Auto brake function is available if the anti-skid function is valid.

On the ECAM wheel page, the average pressure sent the L/H brakes (1, 2, 5, 6) and R/H brakes (3, 4, 7, 8) is indicated with vertical bars.

When the anti-skid is available, the anti-skid indication (A-SKID) appears in green on the ECAM wheel page.

In case of an anti-skid failure, the pressure applied to the corresponding brakes is limited (78 bars /1100 psi). Only pedal braking is then possible. When the anti-skid is not available, the anti-skid indication (A-SKID) appears in amber on the ECAM wheel page.

Y/G ACCU legend is displayed on the Wheel page when a wheel group operates in Alternate mode.

There is an ACCU pressure indicator for each wheel group on the pedestal, one for fwd group (brakes 1 to 4) and one for the aft group (5 to 8).

Accumulator pressure is also displayed on the wheel page.

Each one of these indications will change from green to amber color when the respective accumulator is in low pressure condition.

For more information, when the MORE keys is depressed on the ECAM Control Panel, the ECAM wheel page displays the BRAKE CTL 1, 2 and RBCUs channels status (normal in green and inoperative in amber)

Emergency Braking: Anti-Skid Switch OFF (3)

When the Anti-skid switch is set to ON, anti-skid function is available for the normal or alternate braking modes.

When the Anti-skid switch is set to OFF, the Anti-skid function is deactivated for all the wheel groups. They all operate in Emergency mode. Only the brake pedals can be used in Emergency mode. The brake pressure is maximum 78 bar (1100 psi) from accumulators.

The anti-skid indication (A-SKID) appears in amber on each wheel group on the ECAM wheel page.

Parking Brake and Ultimate Braking (3)

Parking brake mode is active when the handle is set to ON. Parking brake uses the accumulator pressure. Accumulator pressure is monitored on the G & Y Accumulator Pressure Indicator and on the ECAM Wheel page.

On the ECAM wheel page, the average pressure sent the L/H brakes(1,2,5,6) and R/H brakes (3, 4, 7,8) is indicated with vertical bars. When the parking brake is applied, a MEMO message is displayed on memo block and the lower part of the PFD. A Park Brake light is also illuminated on the NLG Steering Disconnect Panel.

Ultimate braking mode is used when the A/C is moving and all the other braking modes are not available.

Close to the parking brake switch is an:" ACCUS REINFLATE "P/B switch.

When it is used, the accumulators are recharged by the HP hydraulic systems through the ARV.

The G & Y Accu Pressure Indicator upper needle shows the pressure in the Yellow Brake Accumulator and the lowest needle in the Green Brake Accumulator.

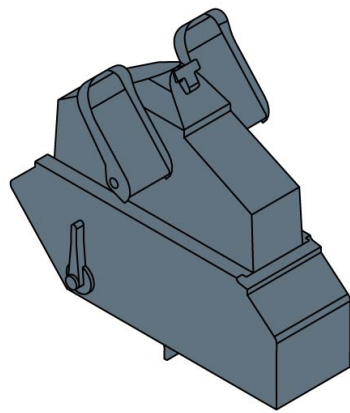

BRAKE PEDALS



AUTOBRAKE CONTROL PANEL

ECP: ECAM Control Panel
ECAM: Electronic Centralized Aircraft Monitoring

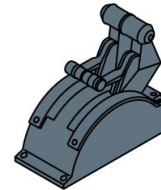

THRUST CONTROL LEVERS



ECP

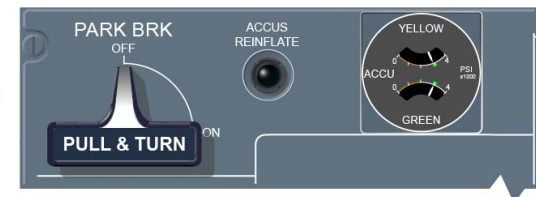

PARKING BRAKE CONTROL PANEL

NORMAL BRAKING WITH BRAKE PEDALS AND AUTO-BRAKE AT LANDING (3) ... PARKING BRAKE AND ULTIMATE BRAKING (3)

V1813401 - V01T0M0 - VM3214BRAKE3001

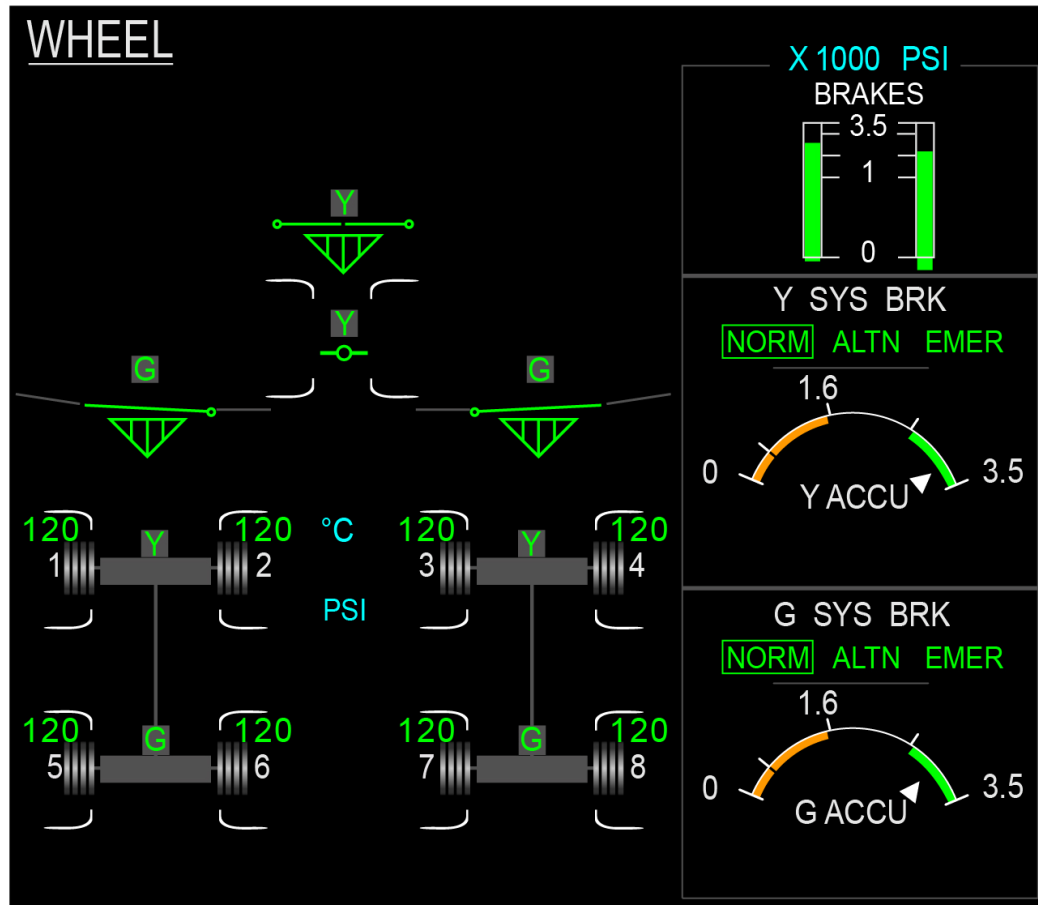

ECAM WHEEL PAGE

NORMAL BRAKING WITH BRAKE PEDALS AND AUTO-BRAKE AT LANDING (3) ... PARKING BRAKE AND ULTIMATE BRAKING

(3)

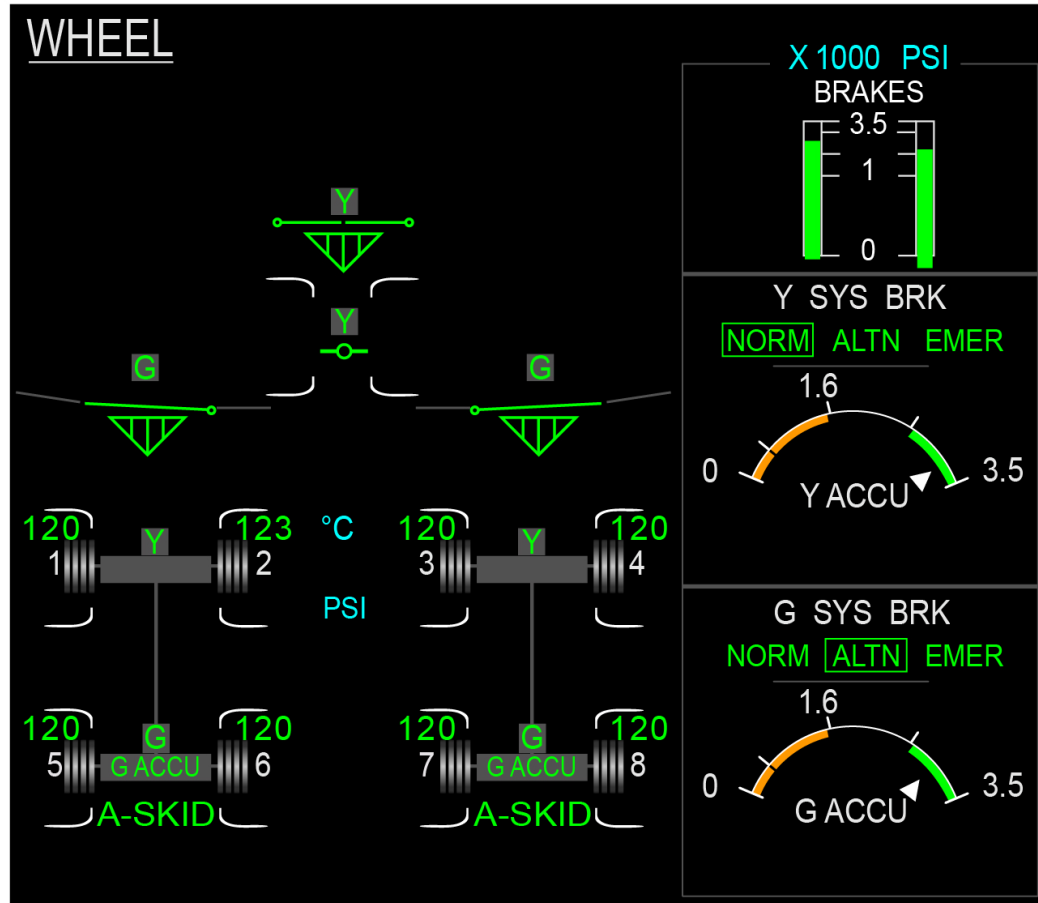

ECAM WHEEL PAGE

NORMAL BRAKING WITH BRAKE PEDALS AND AUTO-BRAKE AT LANDING (3) ... PARKING BRAKE AND ULTIMATE BRAKING (3)

V1813401 - V01T0M0 - VM3214BRAKE3001

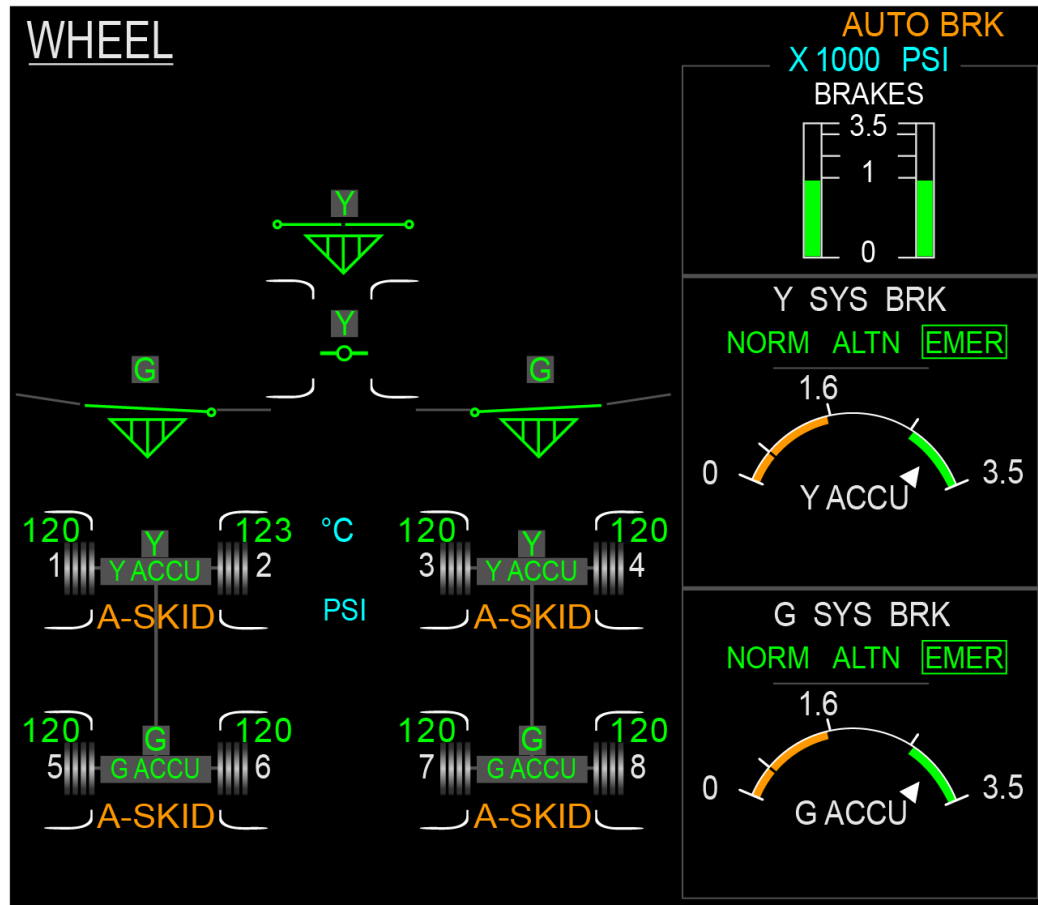

ECAM WHEEL PAGE

NORMAL BRAKING WITH BRAKE PEDALS AND AUTO-BRAKE AT LANDING (3) ... PARKING BRAKE AND ULTIMATE BRAKING

(3)

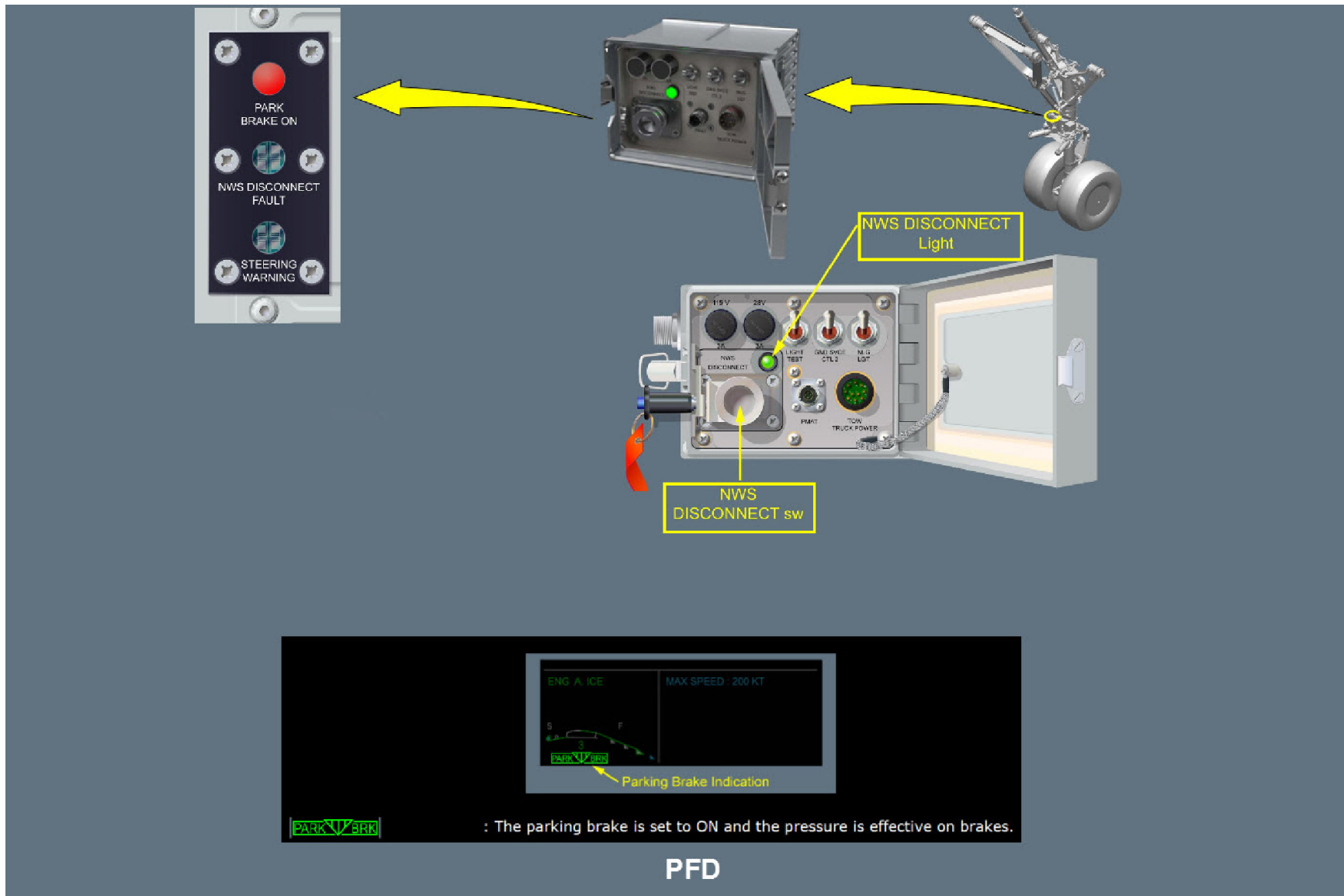

NORMAL BRAKING WITH BRAKE PEDALS AND AUTO-BRAKE AT LANDING (3) ... PARKING BRAKE AND ULTIMATE BRAKING (3)

V1813401 - V01T0M0 - VM3214BRAKE3001



PFD: Primary Flight Display

- A/BRK | The autobrake is armed.
- A/BRK | The autobrake is active.
- BTV | The BTV is armed.
- BTV | The BTV is active.

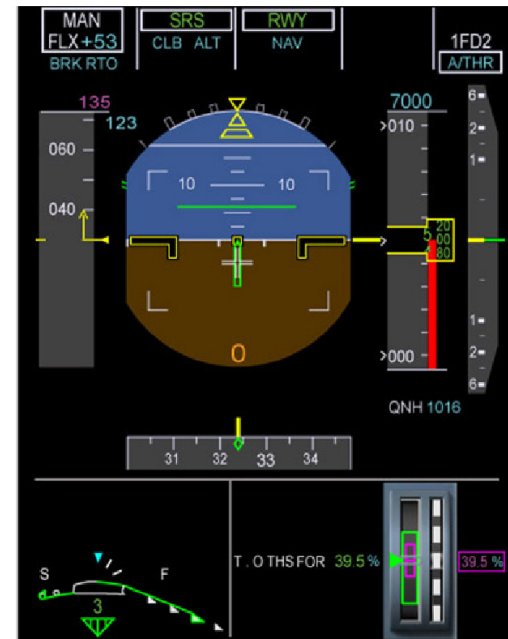

PFD

NORMAL BRAKING WITH BRAKE PEDALS AND AUTO-BRAKE AT LANDING (3) ... PARKING BRAKE AND ULTIMATE BRAKING (3)

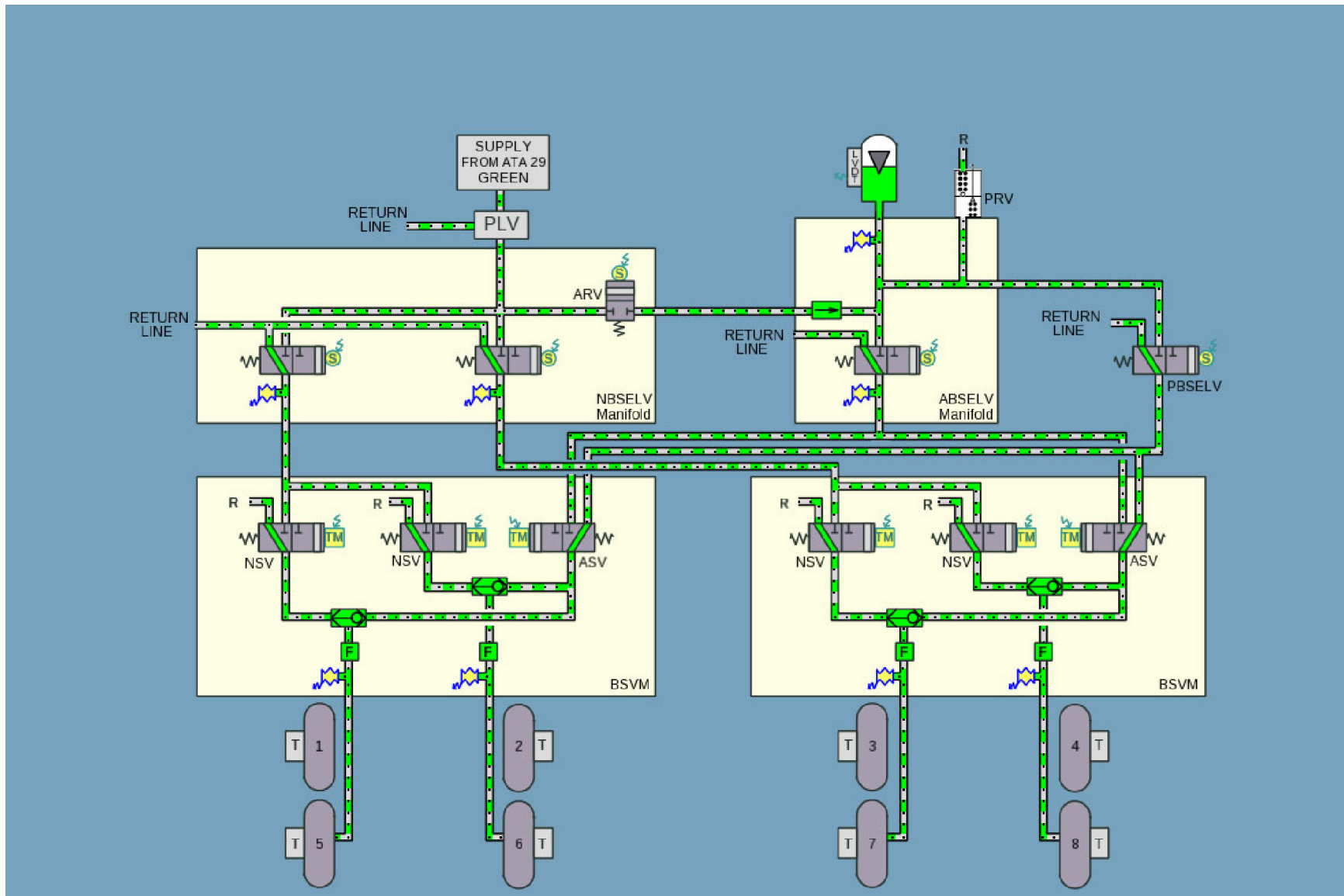

NORMAL BRAKING WITH BRAKE PEDALS AND AUTO-BRAKE AT LANDING (3) ... PARKING BRAKE AND ULTIMATE BRAKING (3)

V1813401 - V01T0M0 - VM3214BRAKE3001

NOSE WHEEL STEERING SYSTEM DESCRIPTION (2)

Aircraft Towing and Push-back Precaution

The Nose Landing-Gear (NLG) shock-absorber has a pair of cams that are used to center the nose wheels during retraction and extension sequences. When the shock absorber extends, the cam on the shock-absorber sliding tube engages into the cam on the shock-absorber main fitting and center the wheels. To prevent cam engagement on the ground, we must make sure that the dimension "H" is NOT more than 385 mm. Cam engagement during towing or pushback operation can cause damage. If the cams are damaged, NLG centering is not possible and prevents Landing Gear (L/G) retraction.

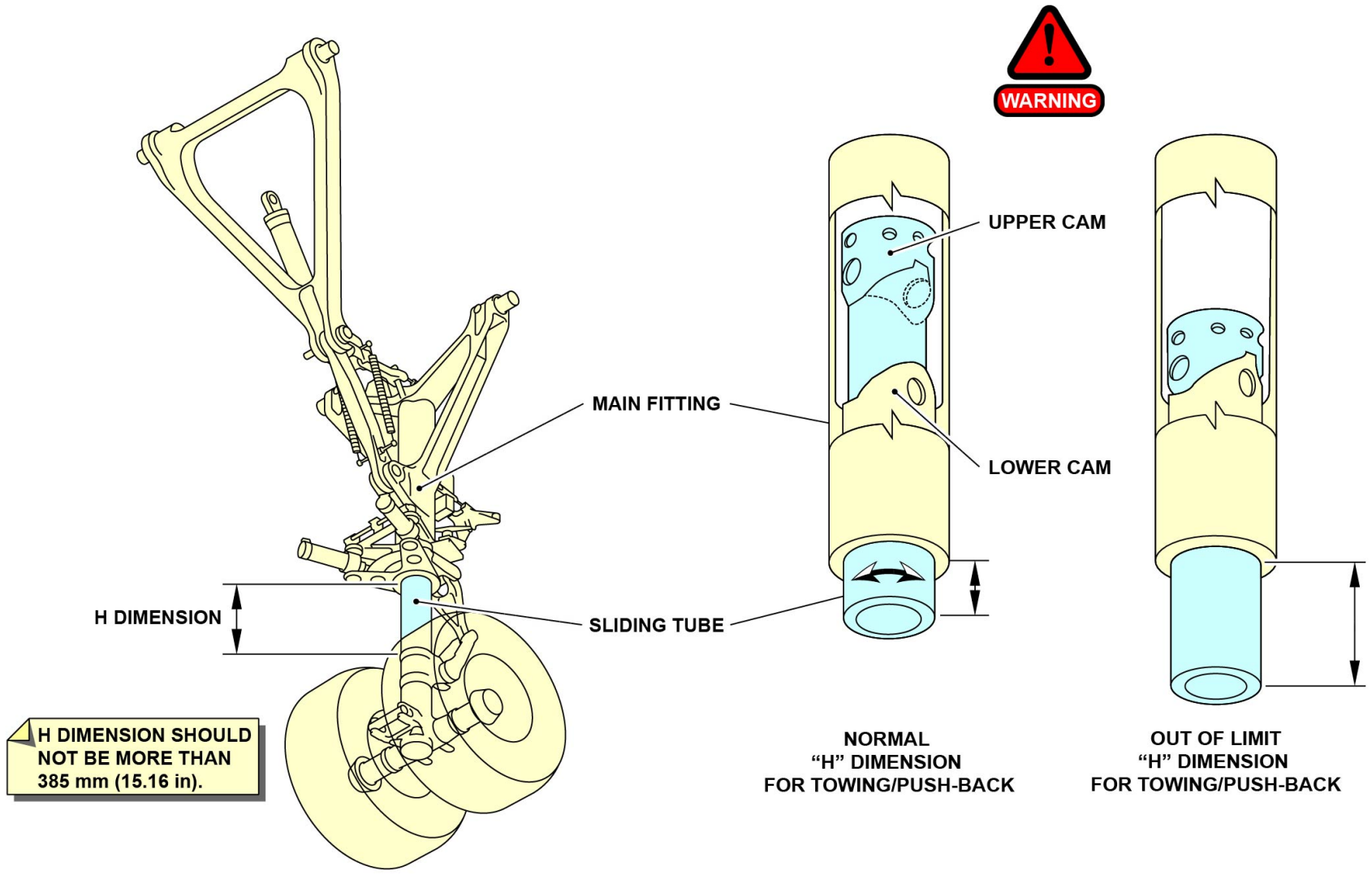

AIRCRAFT TOWING AND PUSH-BACK PRECAUTION

V1813401 - V01T0M0 - VM32DASTEER2301

NOSE WHEEL STEERING SYSTEM DESCRIPTION (2)

Nose Wheel Steering Architecture

In normal mode, the NWS system is supplied by the Yellow hydraulic system. The Wheel Steering Control System (WSCS), which controls the steering operation, is hosted in CPIOMs (WSCS application). This application gets the steering commands from the hand wheels (called also tillers), the rudder pedals (through PRIMary Computers (PRIMs) and SECondary Computers (SECs)) or the autopilot.

The NWS isolation valve is used for the hydraulic supply or the isolation of the steering system. The NWS hydraulic block controls (does the metering of) the hydraulic flow to the actuator chambers and supplies shimmy damping. The actuator pistons move and turn the NLG wheels through push/pull kinematics. The Rotary Variable Differential Transducers (RVDTs) are used to monitor the nose wheel angle and to give feedback to the CPIOMs.

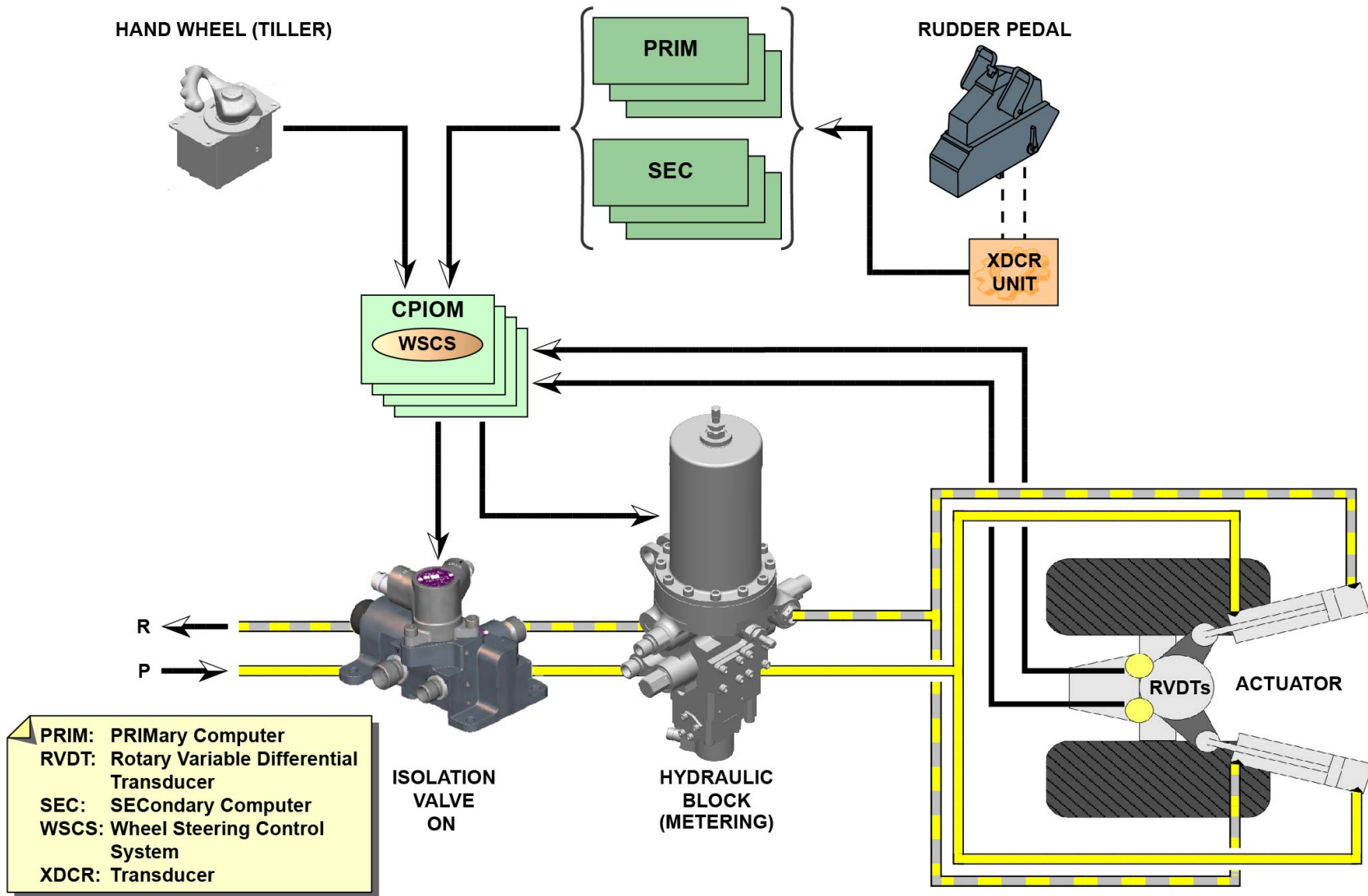

NOSE WHEEL STEERING ARCHITECTURE

V1813401 - V01T0M0 - VM32DASTEER2301

NOSE WHEEL STEERING SYSTEM DESCRIPTION (2)

Nose Wheel Steering Architecture

A tow switch on the steering disconnect panel is used to select the steering system "OFF". The steering disconnect panel is installed on the NLG. This is used to set the NWS in free-castoring mode for towing or pushback operation. The system is set to the towing position with a pin. Actuators are then in a "By-pass mode". A signal is then sent to the CPIOMs where it is processed to de-energize the isolation valve in the closed position and thus prevent the operation of the wheel steering system. A visual indication (green light) shows that the switch is in the towing position on the steering disconnect panel.

WARNING: TO DISCONNECT THE NOSE WHEEL STEERING (NWS) CORRECTLY, THE TOW SWITCH MUST BE OPERATED WITH THE AIRCRAFT FULLY STOPPED. TO RE-CONNECT THE NWS CORRECTLY, THE TOW SWITCH MUST BE OPERATED WITH THE AIRCRAFT FULLY STOPPED AND PARKING BRAKE ON.

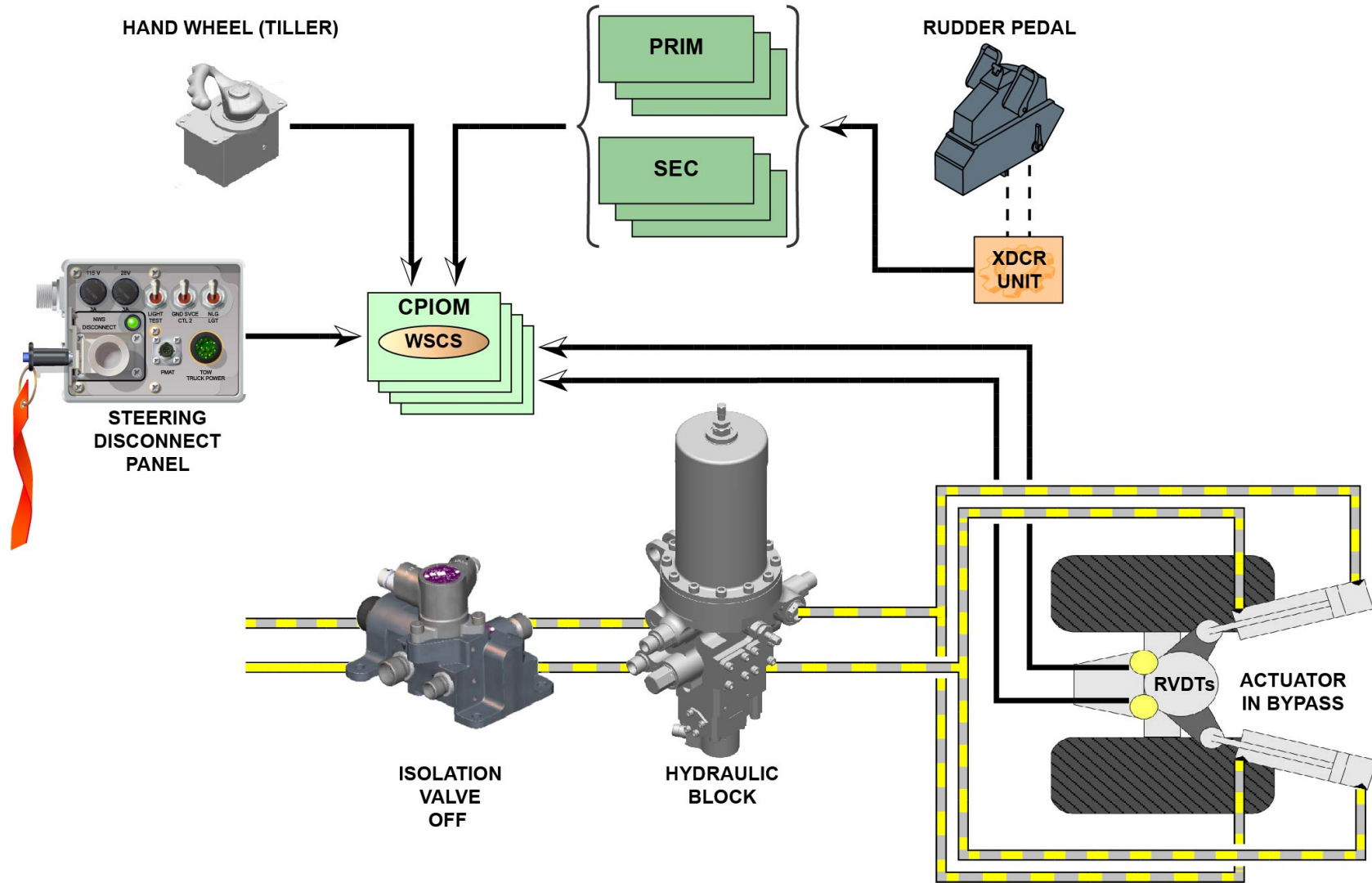

NOSE WHEEL STEERING ARCHITECTURE

V1813401 - V01T0M0 - VM32DASTEER2301

NOSE WHEEL STEERING SYSTEM DESCRIPTION (2)

Steering Handwheel

The two hand wheels are the primary steering inputs. Movement of the hand wheels makes the nose wheels move in the same direction. Each handwheel unit has a pushbutton that, when pushed, causes the WSCS to ignore the rudder pedal commands during pre-flight checks, to prevent nose-wheel tire scrubbing. For Master Minimum Equipment List (MMEL) deactivation, it is possible to electrically disconnect the steering handwheel.

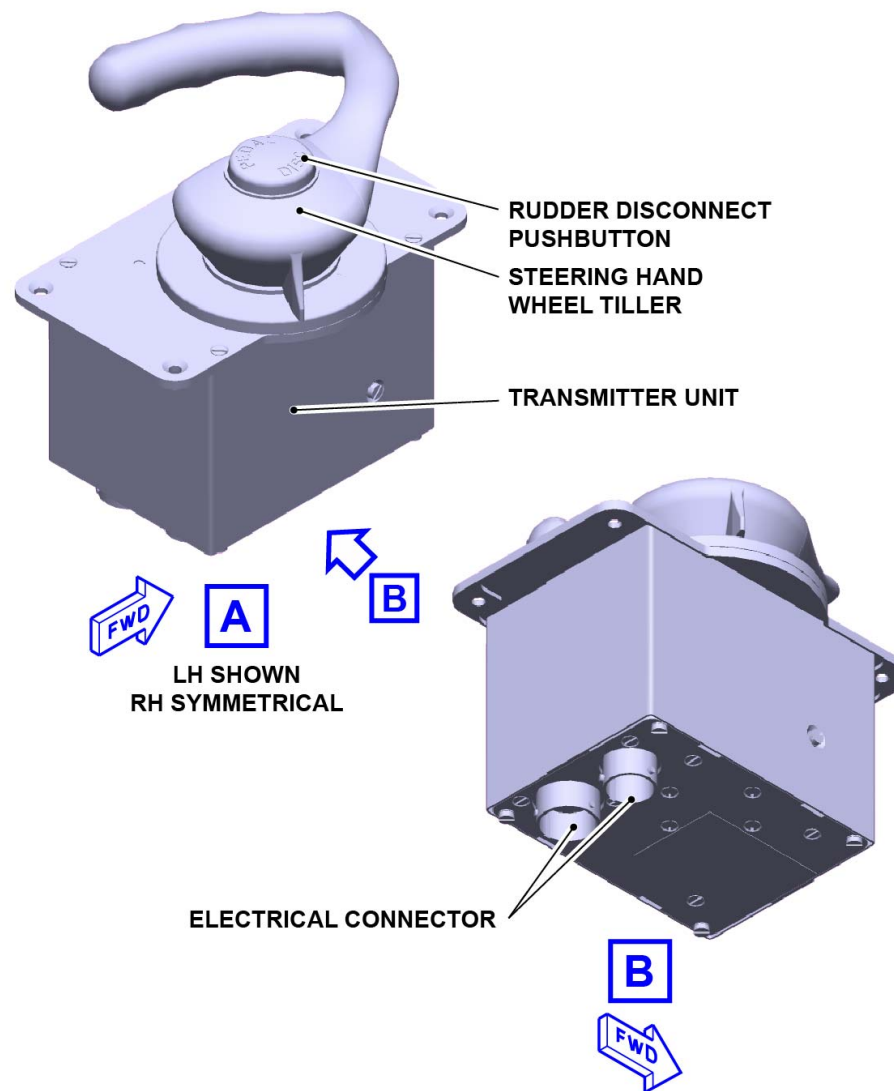
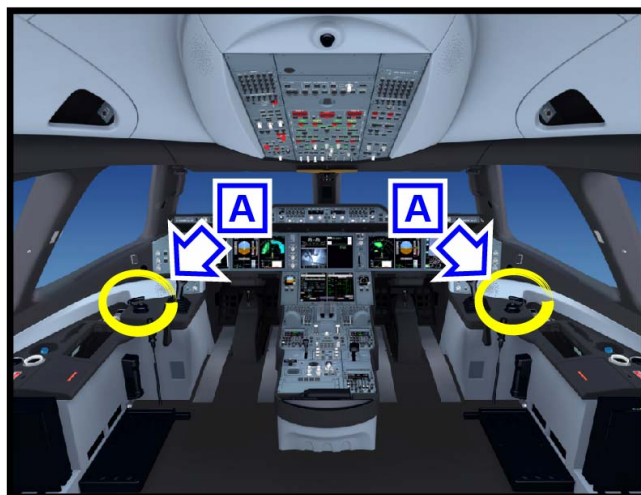

STEERING HANDWHEEL

V1813401 - V01T0M0 - VM32DASTEER2301

NOSE WHEEL STEERING SYSTEM DESCRIPTION (2)

Oversteering Detection

Angle deflection can go to its limit (± 77 degree) during towing/pushback operations. Possible damage can occur on the NLG components. The NLG oversteering detection gives a visual warning of the excess angular travel of the NLG during towing and pushback operations. The system uses proximity sensors and deformable brackets.

If this occurs, there will be three results:

- Generation of Warning Display (WD) alerts
 - Generation of indications to the ground crew
 - Generation of Aircraft Condition Monitoring System (ACMS) reports
- An inspection of the NLG is then necessary.

A mechanical oversteer bracket(s) that is sheared off gives an oversteer indication, with or without the WSCS (example: "dead aircraft" or towing on batteries).

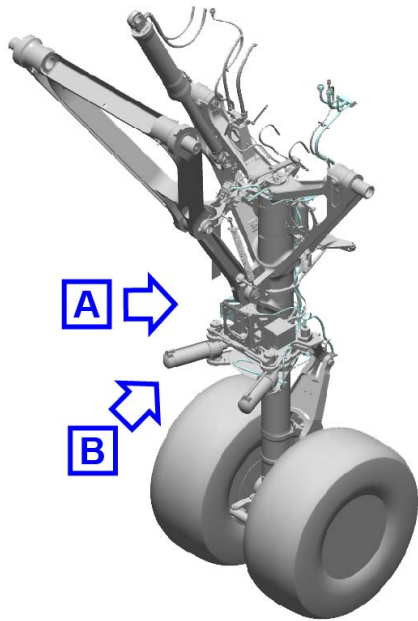

STEERING DISCONNECT
PANEL

STEERING
FAULT LIGHT

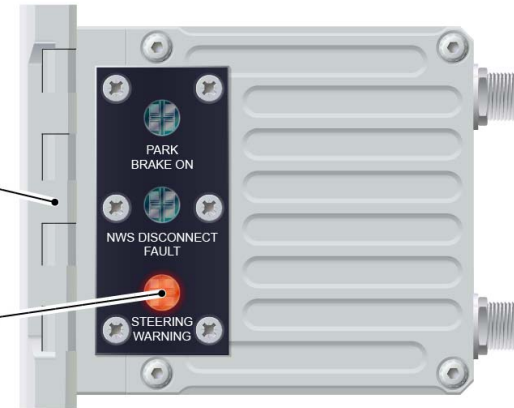

A

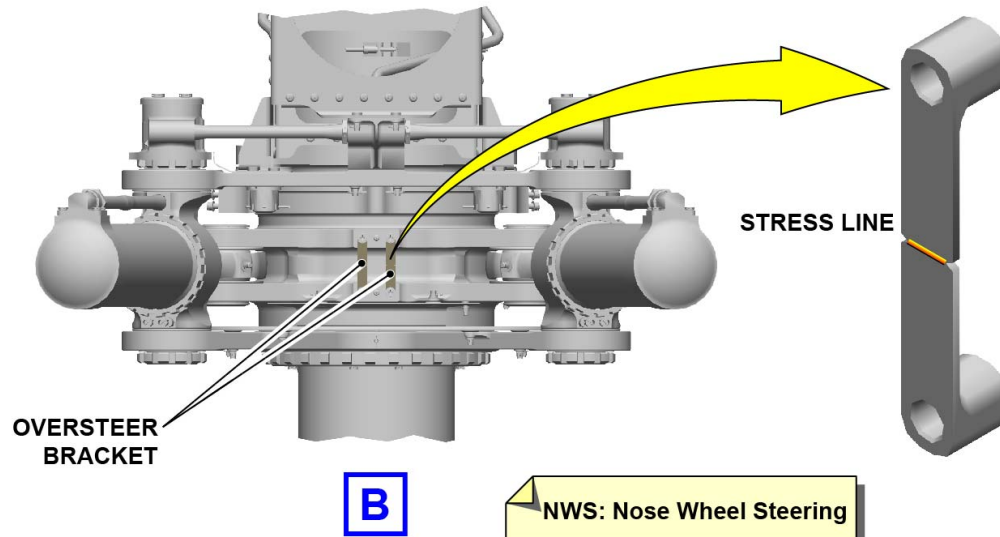

OVERSTEER
BRACKET

STRESS LINE

NWS: Nose Wheel Steering

B

OVERSTEERING DETECTION

V1813401 - V01T0M0 - VM32DASTEER2301

NOSE WHEEL STEERING SYSTEM DESCRIPTION (3)

NWS Description

The Nose Wheel Steering (NWS) is controlled by input signals sent from the cockpit as electrical signals (steer-by-wire). The NWS can be controlled by a combination of the steering hand wheels, rudder pedals or autopilot. These signals are acquired by the CPIOMs (Wheel Steering Control System (WSCS) application) to calculate and monitor the steering commands and feedbacks.

The WSCS contains four CPIOMs and four CRDCs which operate as a redundant side 1 and side 2. An "in charge" switch-over between side 1 and 2 is made at each flight cycle, or if the "ON" side becomes unserviceable. Each side has a Command (COM) CPIOM and a Monitoring (MON) CPIOM.

The CPIOMs collect inputs from the hand wheels, the rudder pedals or the autopilot. Commands from the pedals or autopilot go through the primary flight and guidance system made of the PRIMary Computers (PRIMs) and SECondary Computers (SECs). The input demands are added together and then converted into a nose-wheel demand angle. The hand-wheel demand orders have a decreased angle-deflection authority in relation to aircraft speed (given by Air Data/Inertial Reference Systems (ADIRS)) and are limited to the maximum steering angle (± 72 degree). Hand wheel steering orders are only possible if the aircraft is confirmed to be on the ground (LGERS data). The rudder pedals position and the autopilot orders also have a decreased angle deflection authority in relation to aircraft speed (max. ± 6 degrees).

These control signals are sent to the nose isolation valve and then to the hydraulic block and its servo valve that adjusts the hydraulic flow (Yellow system) to the steering actuators through the different elements of the electro-hydraulic block. Hydraulic fluid must go first through the nose isolation valve, then through the mechanical shut-off valve (also called NWS swivel valve).

In the hydraulic block, the return check valve connects the steering actuators to the return circuit if the HP system is pressurized.

The nose-wheel angle position is measured by two Rotary Variable Differential Transducers (RVDTs). The average value of the two RVDTs is used for the NWS control-loop feedback. The CRDCs supply power current to the selector valve (nose isolation valve) and the Nose Wheel Steering Servo Valve (NWSSV) and they also collect inputs from the RVDTs.

CPIOMs MON supply ground signal to the nose isolation valve.

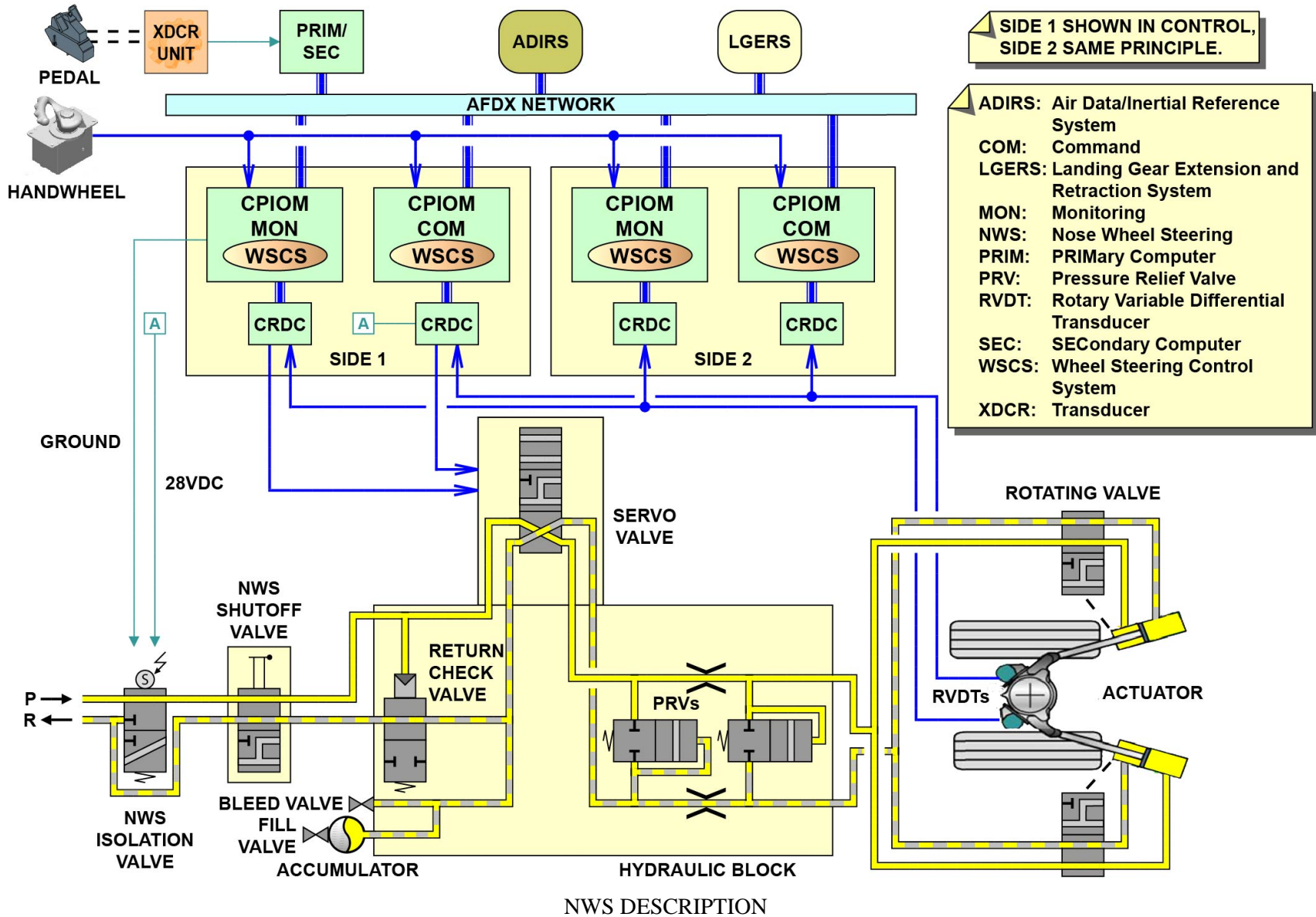

V1813401 - V01T0M0 - VM32DBSTEER3001

NOSE WHEEL STEERING SYSTEM DESCRIPTION (3)

NWS Logic and conditions

The logic and conditions for the NWS are:

- Nose Landing Gear (NLG) and Main Landing Gear (MLG) compressed (given by LGERS)
- Minimum of one engine master lever at "ON" position
- Yellow hydraulic system pressurized
- Towing lever not in "TOWING" position.

The nose wheel and rudder angle deflections are related to the ground speed. At low speed, angle deflections can reach the maximum value (72 degrees from the hand wheels and 6 degrees from the rudder pedals and autopilot). When the speed increases, the angle deflections gradually decrease.

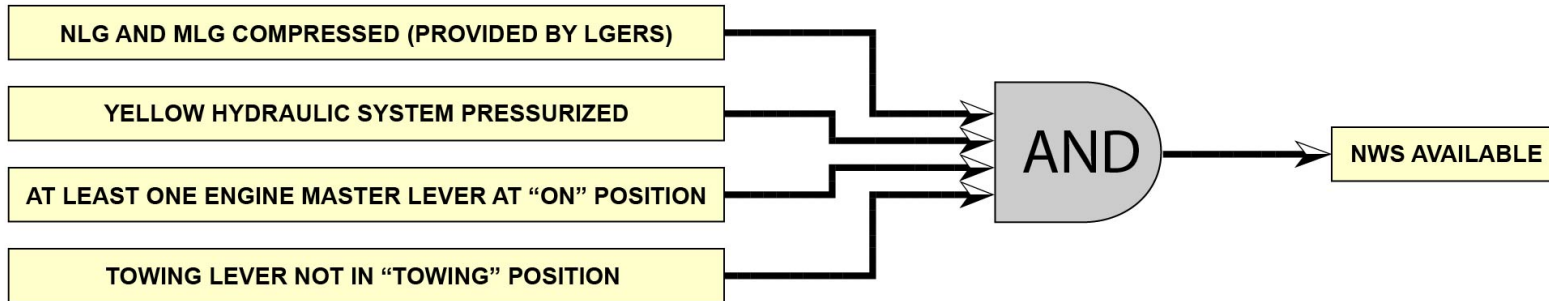

MLG: Main Landing Gear
NLG: Nose Landing Gear

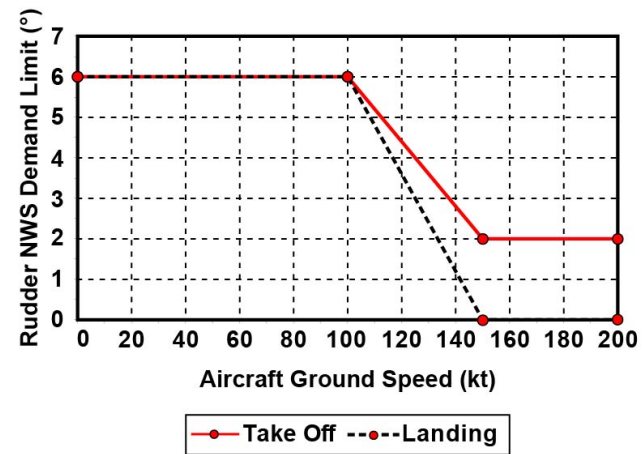
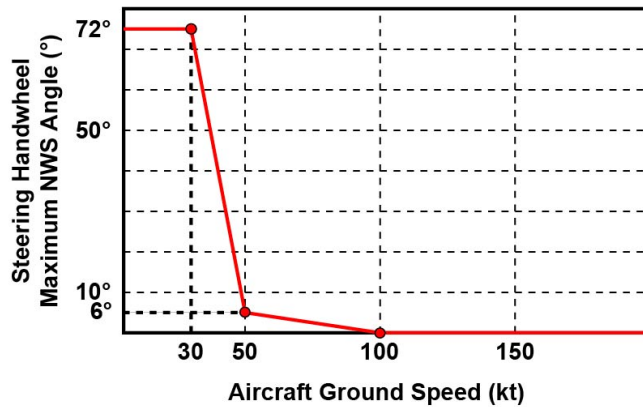

NWS LOGIC AND CONDITIONS

V1813401 - V01T0M0 - VM32DBSTEER3001

NOSE WHEEL STEERING SYSTEM DESCRIPTION (3)

Castoring Mode

If there is a system failure, a hydraulic system failure or a towing pin engaged in the Steering Disconnect Panel (SDP), the NWS can freely castor in the direction of aircraft travel. During nose wheel castoring, a remaining pressure is kept in the system by the accumulator and the return check valve. This prevents cavitations in the actuator chambers. The hydraulic fluid in the actuators can move from one actuator to the other. The anti-shimmy damping function is the same as in the powered steering mode.

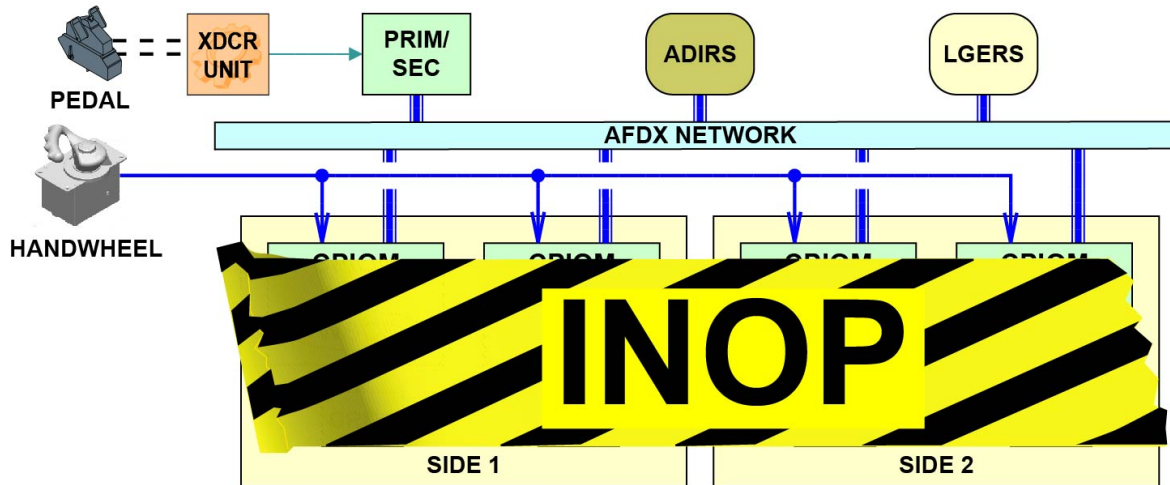

IF OFF OR INOP

CASTORING MODE

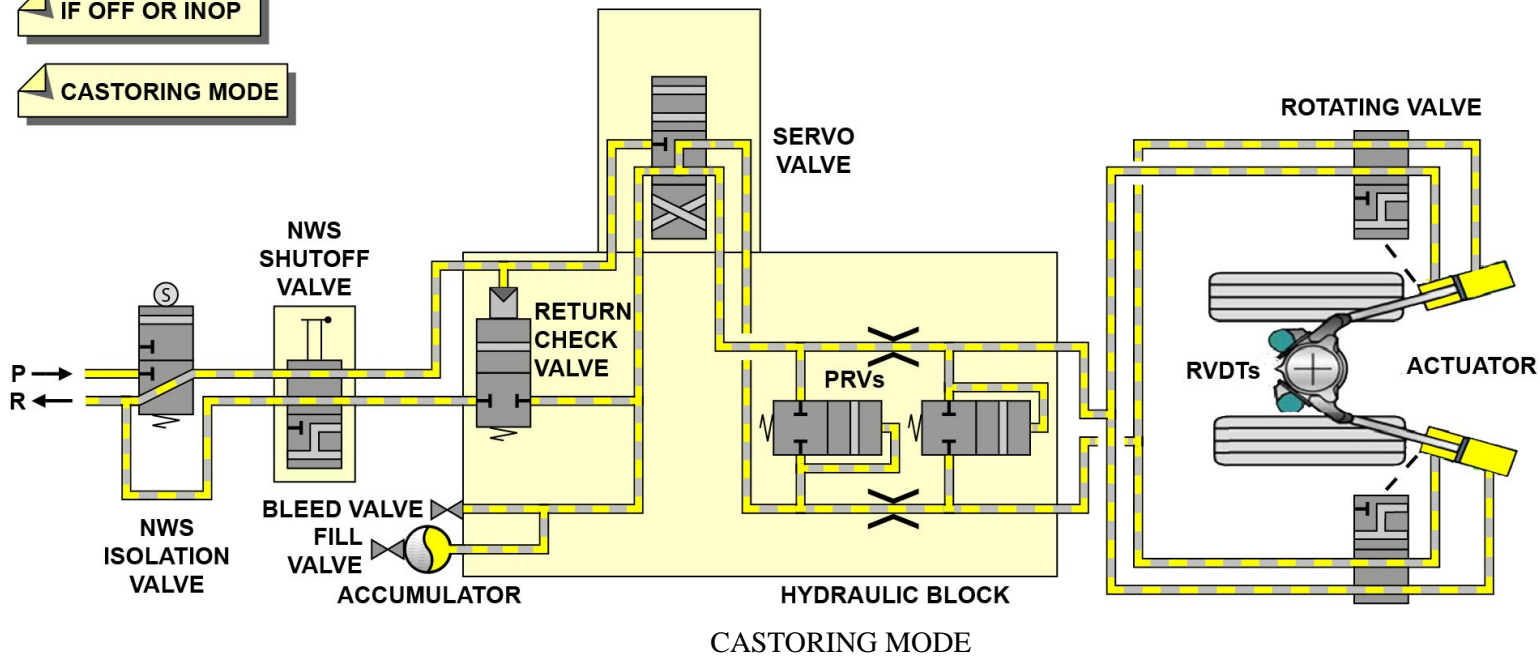

V1813401 - V01T0M0 - VM32DBSTEER3001

NOSE WHEEL STEERING SYSTEM DESCRIPTION (3)

Components Function/Description

The NWS isolation valve is used for the hydraulic isolation/supply of the steering system. It is energized by the CRDC on a command from the CPIOM (power supply) and the CPIOMs MON (ground signal). It is opened when the solenoid is energized and closed when the solenoid is de-energized.

The NWS mechanical shutoff valve connects the NWS isolation valve to the hydraulic block. This valve is mechanically opened when the NLG is extended and closed when the NLG retracts, to isolate the steering system.

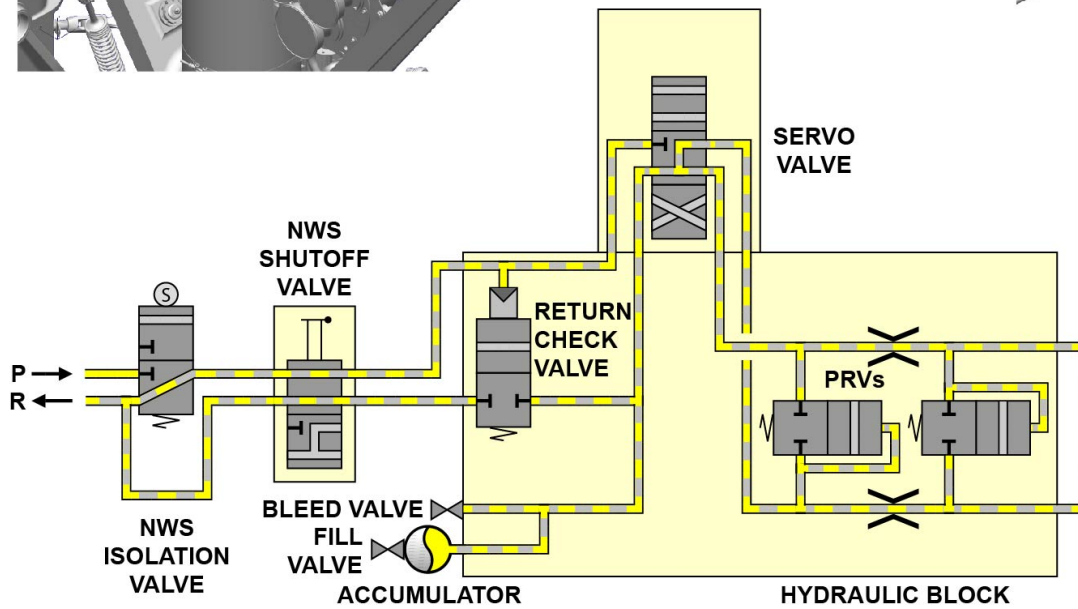
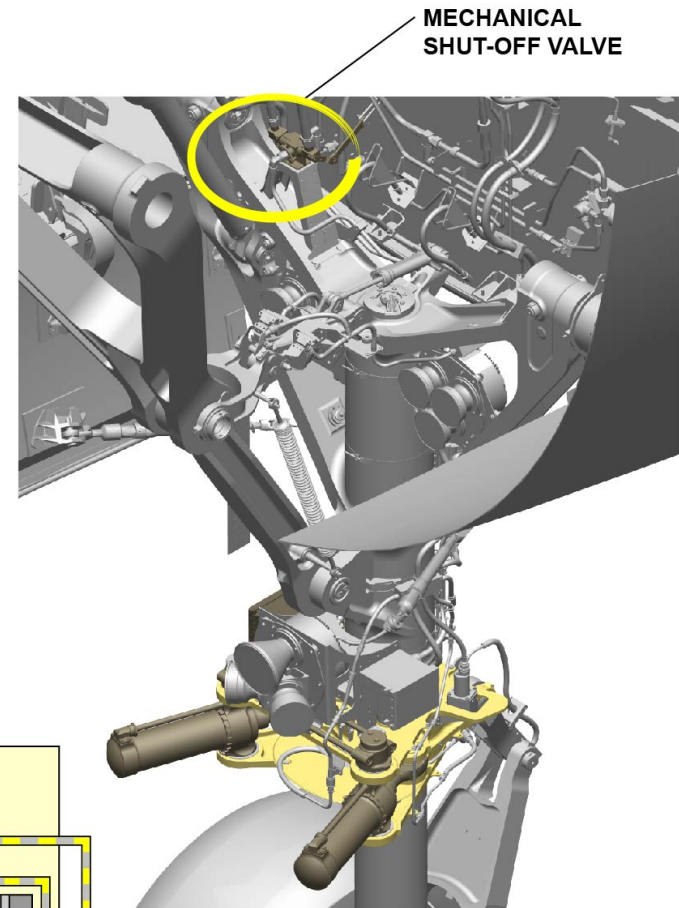
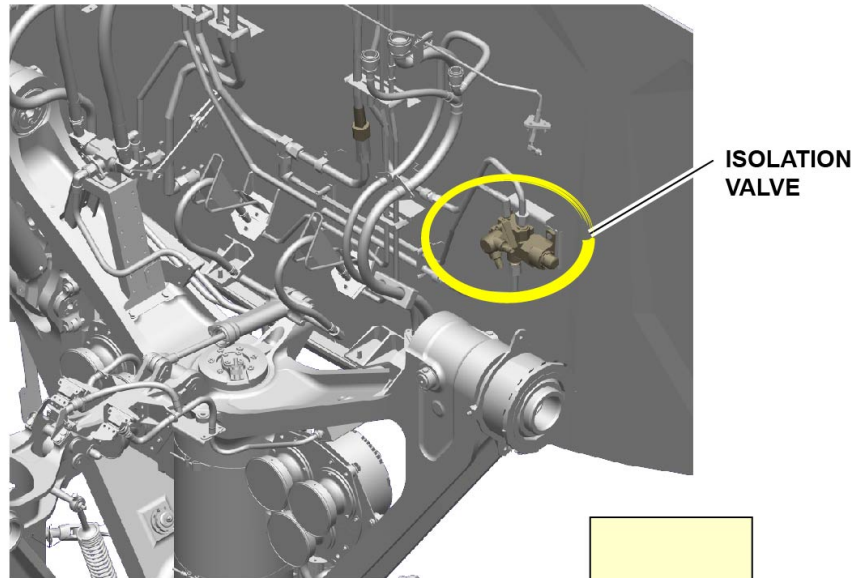

COMPONENTS FUNCTION/DESCRIPTION

V1813401 - V01T0M0 - VM32DBSTEER3001

NOSE WHEEL STEERING SYSTEM DESCRIPTION (3)

Components Function / Description

Shimmy damping is done by the NWS hydraulic block. This contains hydro-mechanical equipment for towing and free castoring. It contains a nitrogen filling valve, a bleed valve, pressure relief valves, a return valve, and a refilling valve. An accumulator supplies a stored charge of pressurized hydraulic fluid to adjust for temperature variations and to prevent cavitations during castoring and towing. The NWS servo valve is energized by the CRDC on a command from the CPIOM. It ensures the metering of the hydraulic flow to the actuator chamber. A nitrogen filling valve is on the top of the hydraulic block to pre-charge the accumulator with nitrogen. A maintenance bleed valve is also on the bottom of the hydraulic block to bleed residual air pockets in the hydraulic block. It is also used to depressurize the hydraulic block before a line disconnection.

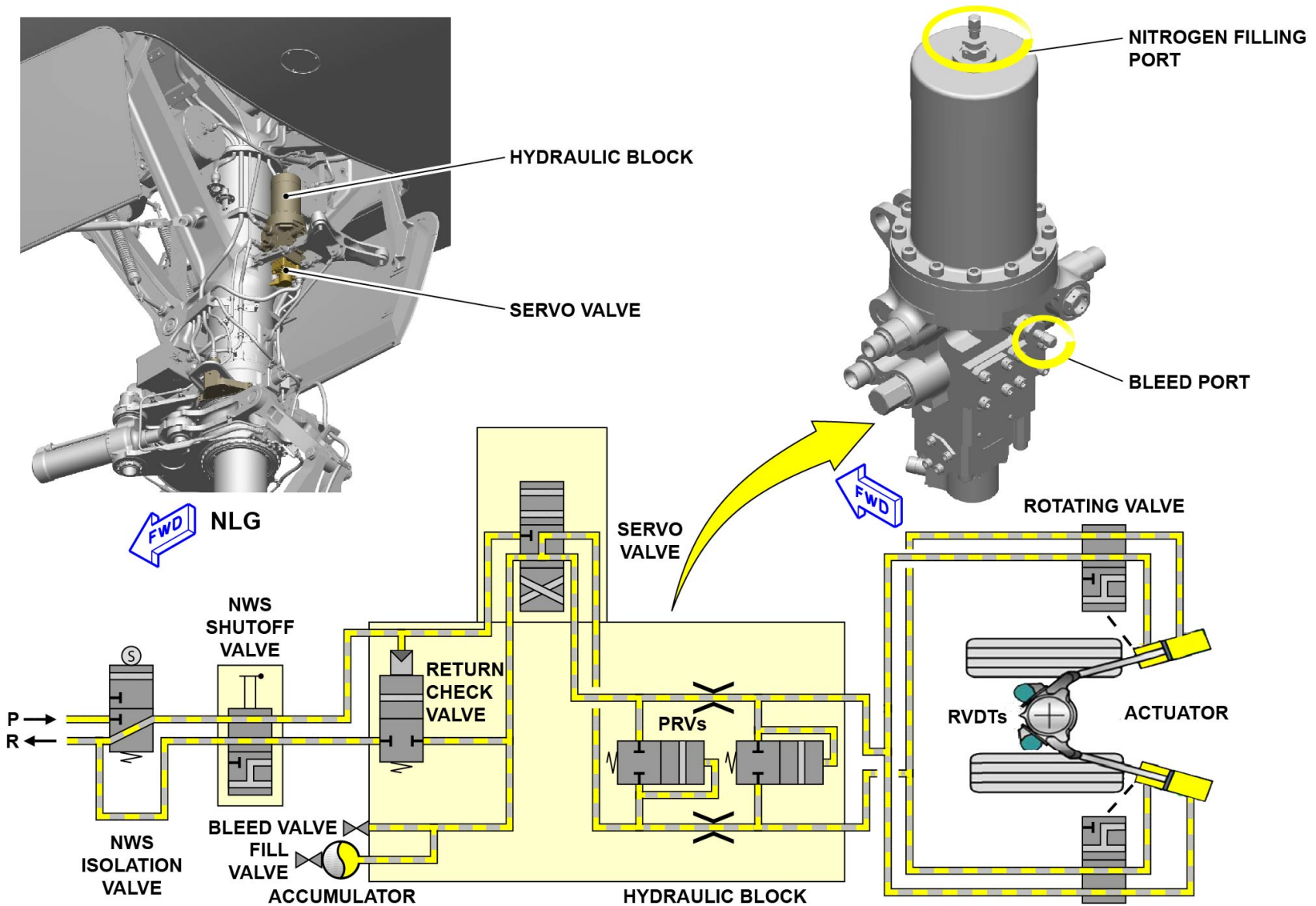

COMPONENTS FUNCTION / DESCRIPTION

V1813401 - V01T0M0 - VM32DBSTEER3001

NOSE WHEEL STEERING SYSTEM DESCRIPTION (3)

Components Function / Description

The NWS actuators translate pistons which then turn the NLG wheels through push/pull kinematics. The steering torque is sent to the nose wheels through the torque links on the nose landing gear.

Rotating selector valves transfer fluid from the hydraulic block to the actuator chambers as a function of the NLG position.

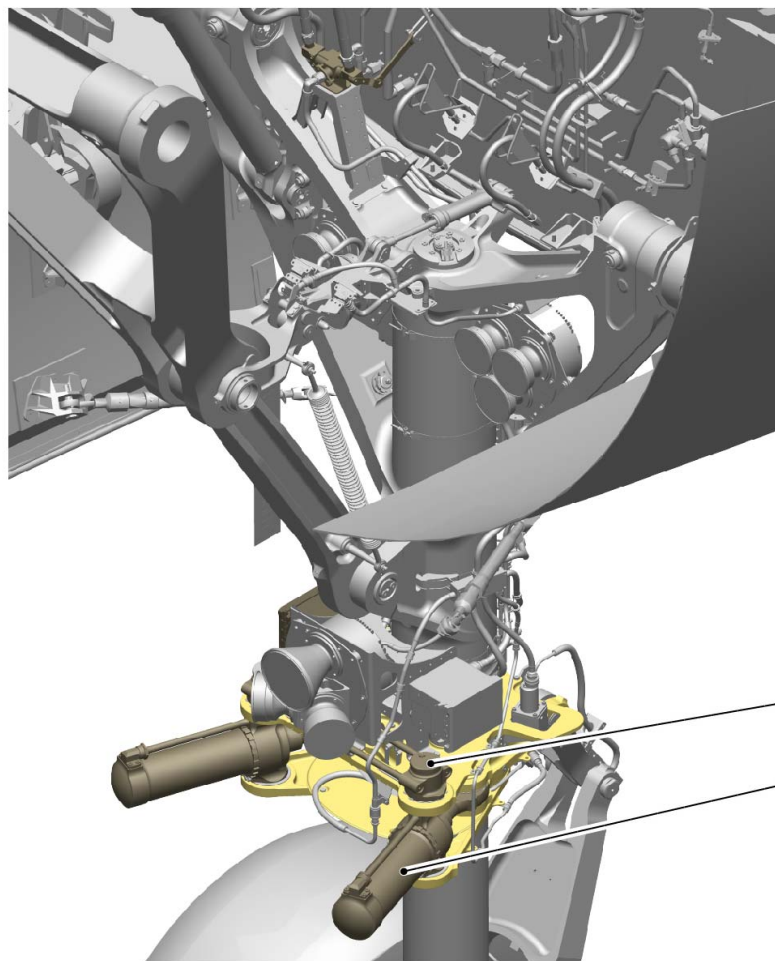

**ROTATING
SELECTOR VALVE**

ACTUATOR

COMPONENTS FUNCTION / DESCRIPTION

V1813401 - V01T0M0 - VM32DBSTEER3001

NOSE WHEEL STEERING SYSTEM DESCRIPTION (3)

Actuators movement

The steering mechanism in the nose wheel has two linear hydraulic actuators which operate around a rotary collar.

The actuators apply linear motion on the rotating collar, which gives the steering rotation. They are attached between the upper and lower stationary flanges and the rod ends are attached on the rotating collar, which thus transmits its movement. The hydraulic connection of the actuator enables the cross-over when an actuator reaches its fully retracted position.

During the movement, one actuator is always extended and the other one retracted until the cross-over point moves to 20 degrees. At the cross-over point, the NWS rotating selector valve switches the pressure supply inside the actuator, between the annulus and the piston area, and continues to extend. Only one actuator moves the nose wheel between 18 and 20 degrees.

The minimum torque given by the actuator is at the cross-over point. The maximum angle at which the nose wheel can turn without the disconnection of a part of the steering system is 72 degrees.

ROTATING SELECTOR VALVES

MOVEMENT BETWEEN 0° AND 18°

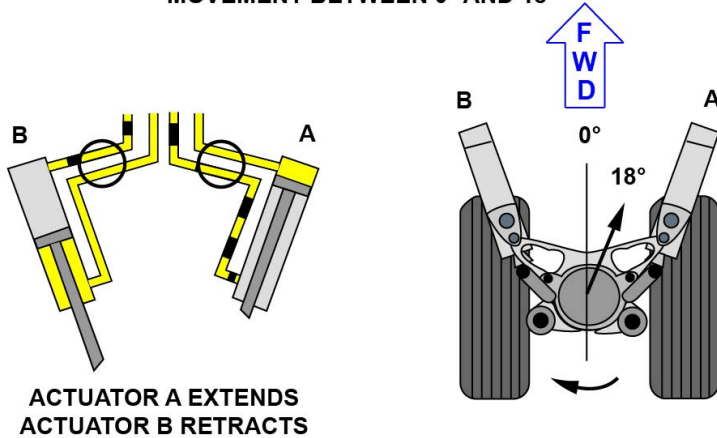

MOVEMENT BETWEEN 18° TO 20°
(CROSS OVER POINT)

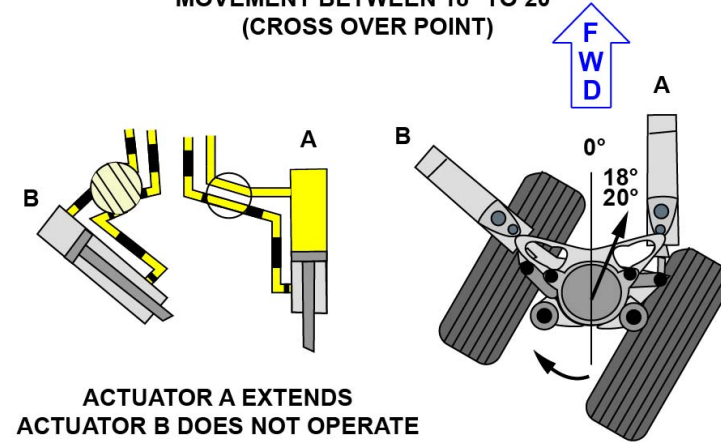

MOVEMENT BETWEEN 20° TO 72°

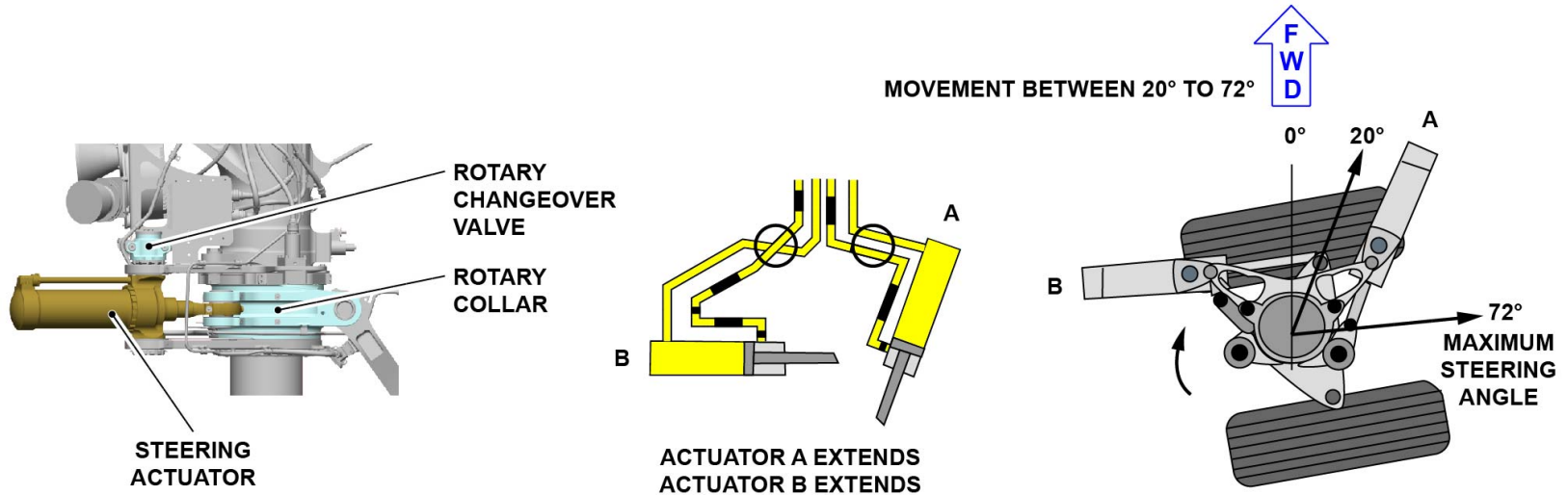

ACTUATORS MOVEMENT

V1813401 - V01T0M0 - VM32DBSTEER3001

STEP 1

STEP 2

STEP 3

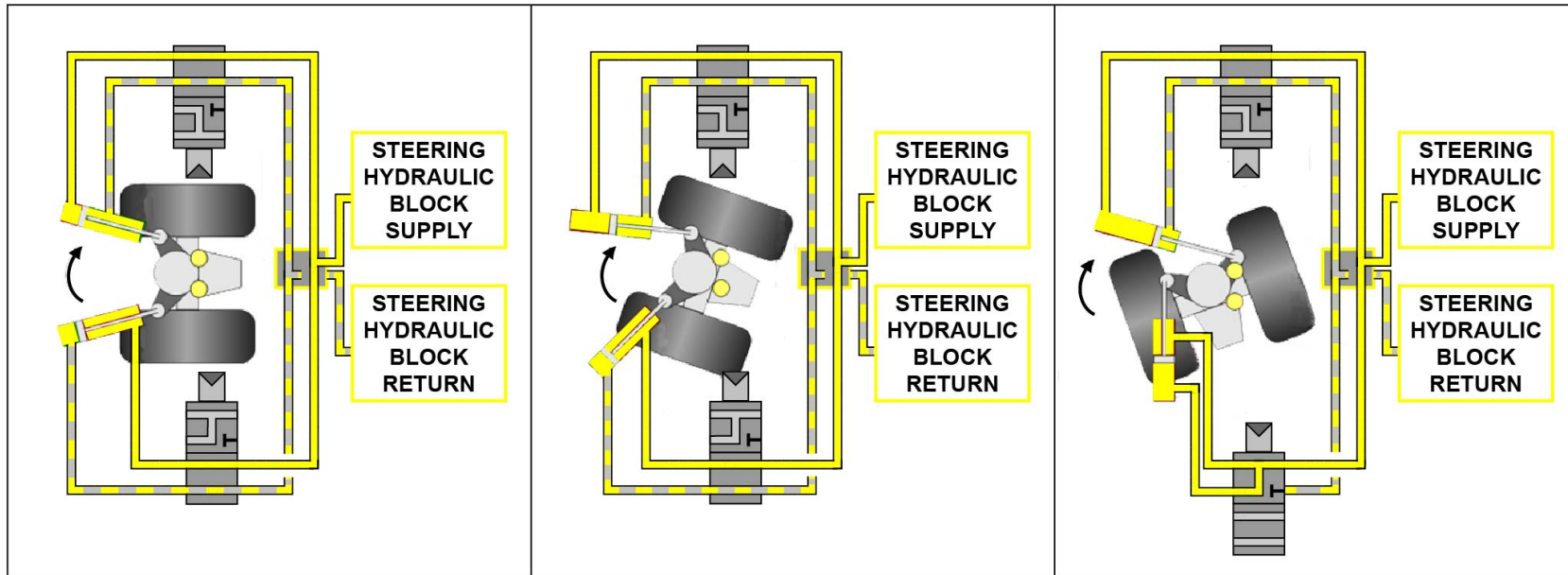

ROTATING SELECTOR VALVE
CONFIGURATION AT 0°-
TURN AWAY FROM CENTER

ROTATING SELECTOR VALVE
CONFIGURATION BETWEEN
0° AND ~18°-
TURN AWAY FROM CENTER

ROTATING SELECTOR VALVE
CONFIGURATION BETWEEN
~20° AND 72°-
TURN AWAY FROM CENTER

ACTUATORS MOVEMENT

V1813401 - V01T0M0 - VM32DBSTEER3001

STEP 4

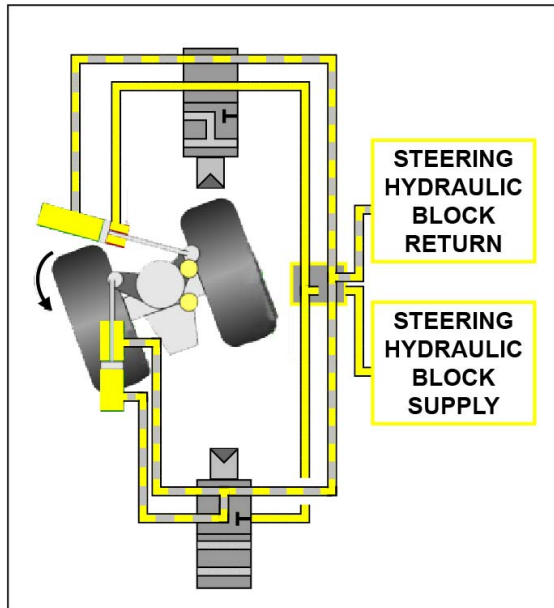

ROTATING SELECTOR VALVE CONFIGURATION BETWEEN 72° AND ~20°- TURN AWAY FROM CENTER

STEP 5

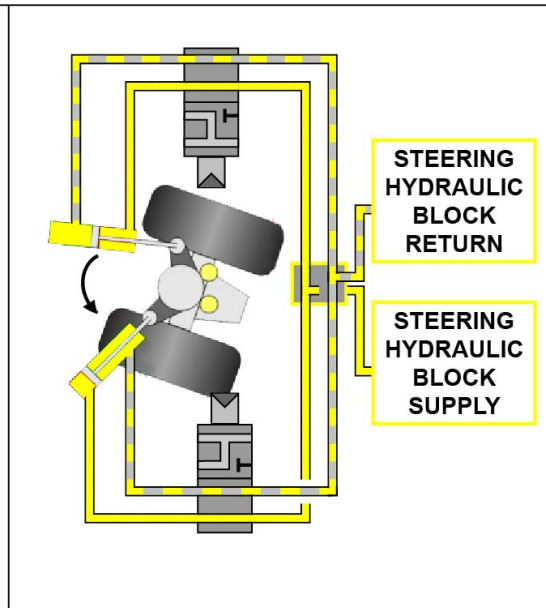

ROTATING SELECTOR VALVE CONFIGURATION BETWEEN 0° AND ~18°- TURN AWAY FROM CENTER

STEP 6

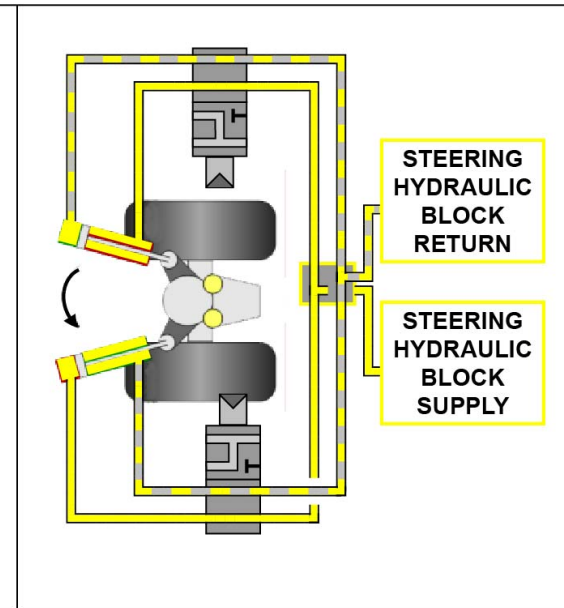

ROTATING SELECTOR VALVE CONFIGURATION AT 0°- TURN AWAY FROM CENTER

ACTUATORS MOVEMENT

V1813401 - V01T0M0 - VM32DBSTEER3001

NOSE WHEEL STEERING SYSTEM DESCRIPTION (3)

Components Function / Description

RVDTs are used to monitor the nose wheel angle and give feedback to the CRDCs and then the CPIOMs for a closed control loop of the angle position. The RVDTs are installed on the NLG:

- An external screw is used to adjust the RVDT sensor zero-position.
- An automatic locking device keeps the RVDT input pinion in its centered position before the unit is installed on the gear.

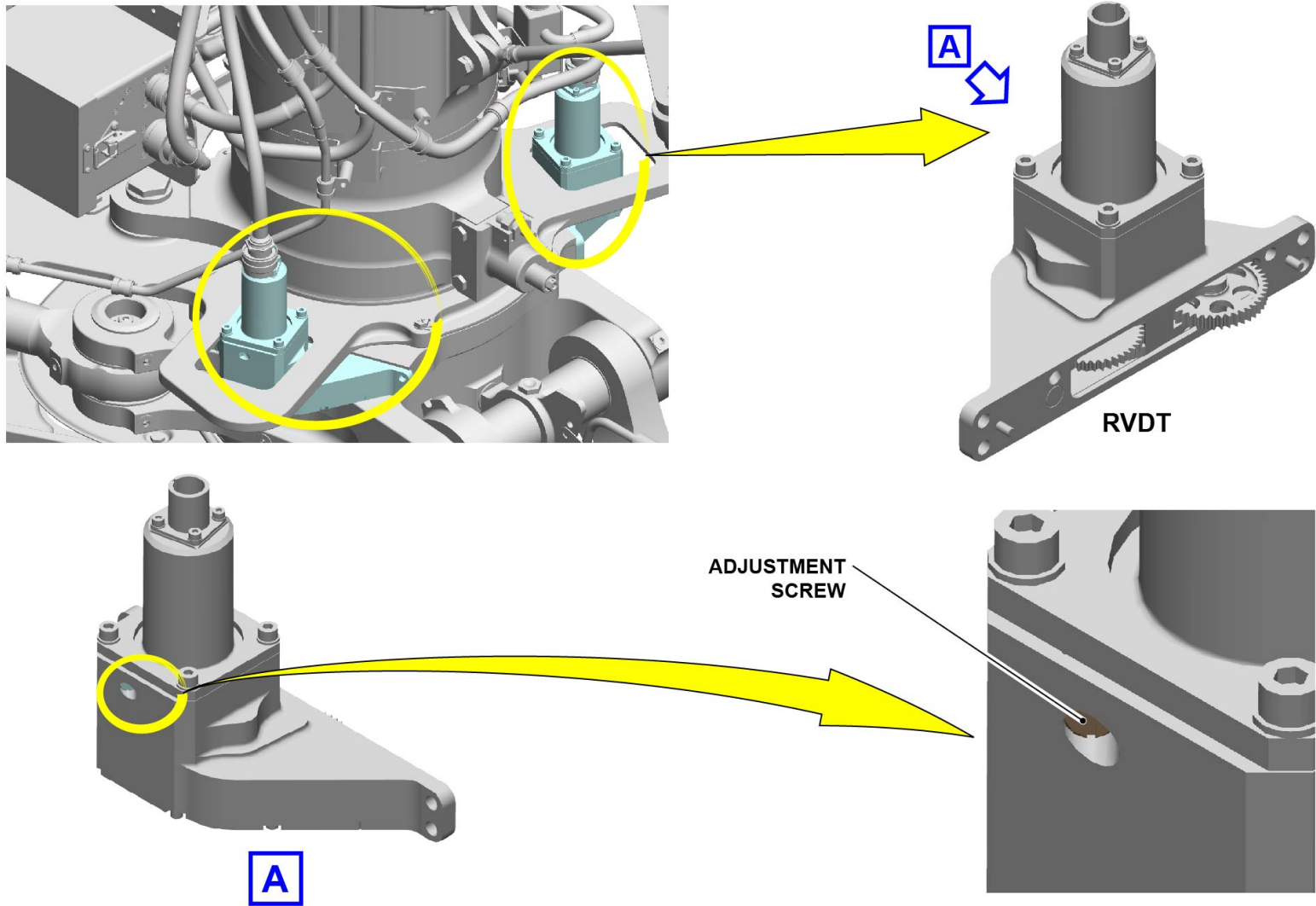

COMPONENTS FUNCTION / DESCRIPTION

VI1813401 - V01T0M0 - VM32DBSTEER3001

NOSE WHEEL STEERING SYSTEM DESCRIPTION (3)

Active Differential Braking (Back-Up Steering)

If there is a NWS failure, the blockage of the active runway on landing is possible. A backup steering mode is used for operational reasons. The Automatic Differential Braking (ADB) mode allows the flight crew to vacate the runway with the hand wheels.

The ADB uses the aircraft braking system to command differential braking orders to move the aircraft (the ADB uses only brakes 5 to 8). The ADB function uses three systems:

- WSCS: ADB management
- Flight Control and Guidance System (FCGS): ADB control
- Braking Control System (BCS): ADB actuation

The WSCS uses hand-wheel demand inputs. The FCGS receives the demand and sends commands to the BCS. The pressure on the related brake units is adjusted in relation to the FCGS inputs and the aircraft position (ADIRS data).

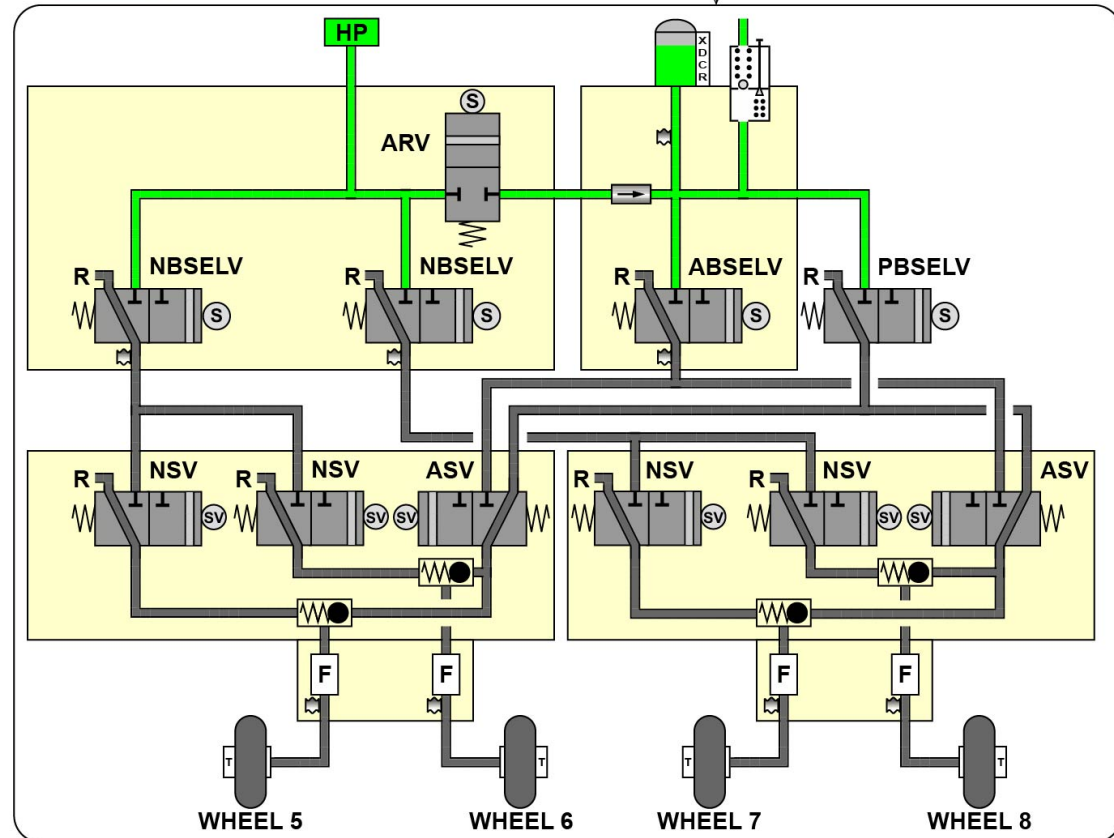
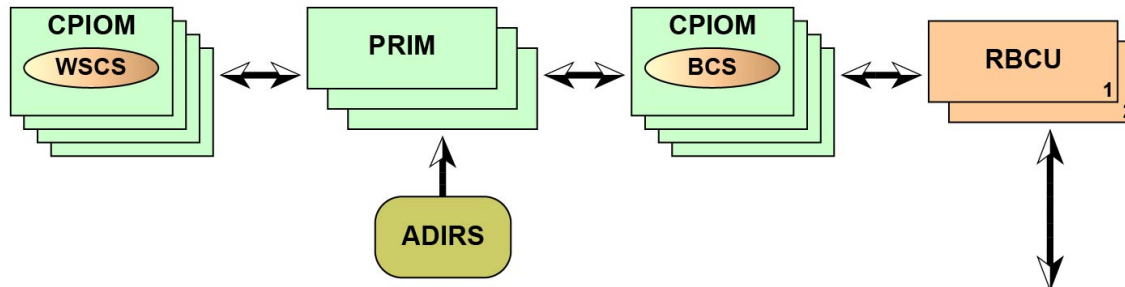

- ABSELV: Alternate Brake Selector Valve
- ARV: Alternate Refill Valve
- ASV: Alternate Servo Valve
- BCS: Braking Control System
- NBSELV: Normal Brake Selector Valve
- NSV: Normal Servo Valve
- PBSELV: Park Brake Selector Valve
- RBCU: Remote Braking Control Unit
- SV: Servo Valve

ACTIVE DIFFERENTIAL BRAKING (BACK-UP STEERING)

V1813401 - V01T0M0 - VM32DBSTEER3001

NOSE WHEEL STEERING SYSTEM DESCRIPTION (3)

Active Differential Braking (Back-Up Steering)

The pressure on brake units 5 and 6 is adjusted because a left turn request is made by the hand wheels.

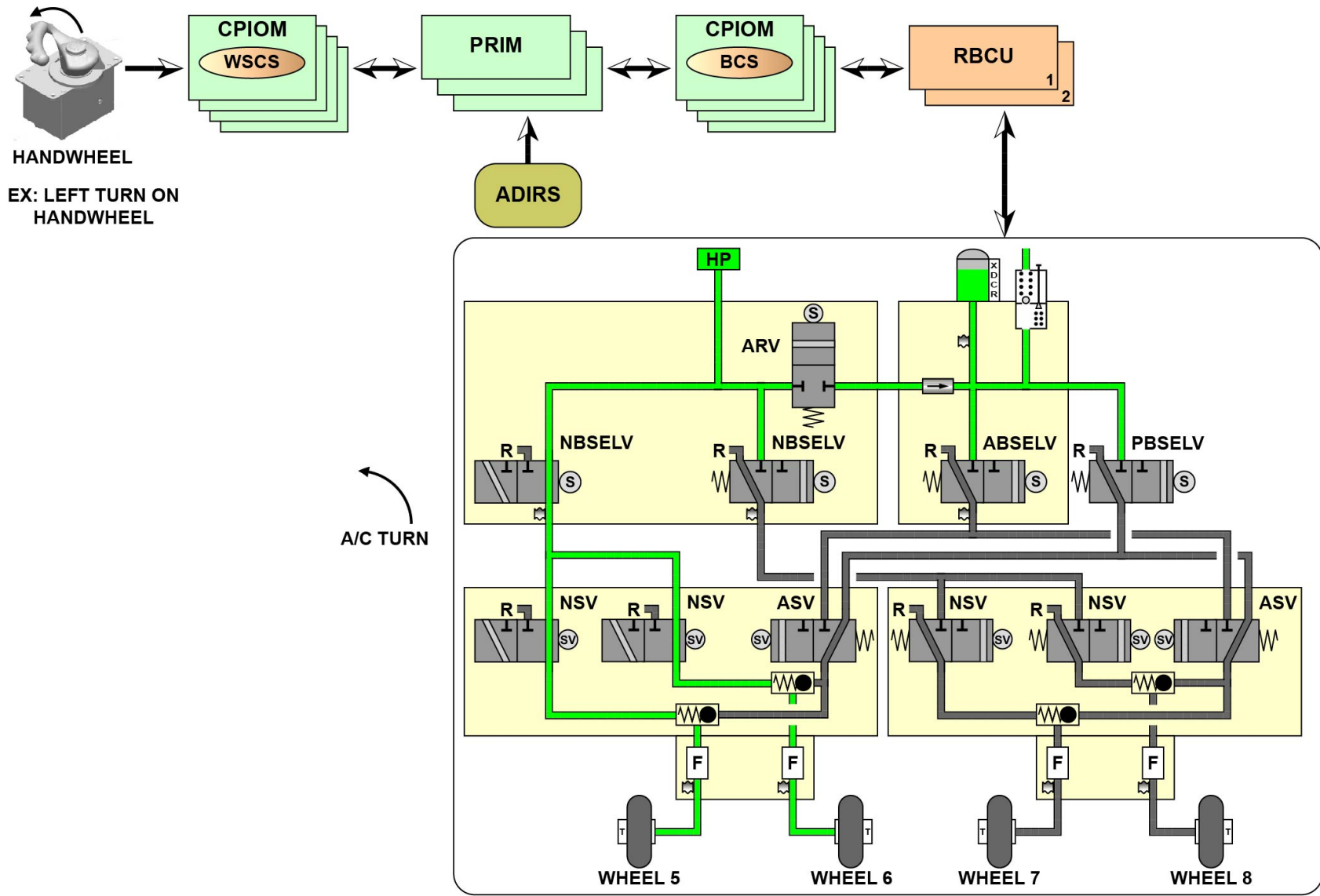

ACTIVE DIFFERENTIAL BRAKING (BACK-UP STEERING)

V1813401 - V01TOM0 - VM32DBSTEER3001

NOSE WHEEL STEERING MAINTENANCE (2/3)

NWS RVDT Electrical Zero Check and Rigging

RVDT Electrical Zero Check

The function of this maintenance module is to give guidelines during an Rotary Variable Differential Transducer (RVDT) adjustment task, on the Nose Landing Gear (NLG) steering system.

To set the electrical zero of the RVDTs, we must make sure that the NLG is physically aligned and centered (mechanical zero) with given tolerances. The check procedures are:

- NLG Zero Markings
- NLG Actuator Stroke Measurement
- NLG Centering Cams.

NLG Zero Markings

There are special position marks on the NLG which show the NLG zero position to a given accuracy.

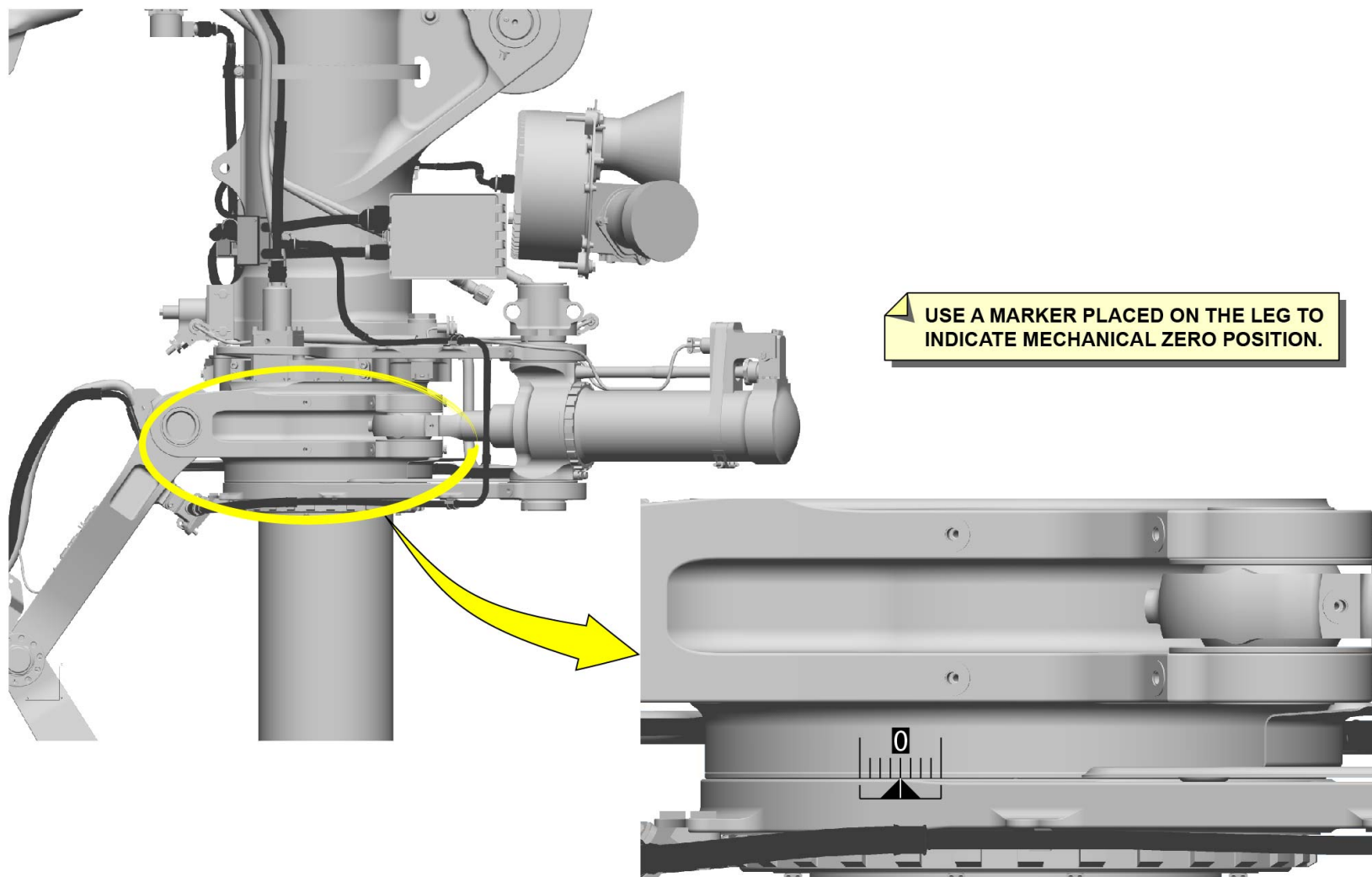

NWS RVDT ELECTRICAL ZERO CHECK AND RIGGING - RVDT ELECTRICAL ZERO CHECK & NLG ZERO MARKINGS

V1813401 - V01T0M0 - VM32M2STEER3001

NOSE WHEEL STEERING MAINTENANCE (2/3)**NWS RVDT Electrical Zero Check and Rigging (continued)****NLG Actuator Stroke Measurement**

If it is possible to accurately measure the stroke of each steering actuator, it is thus possible to calculate the NLG axle steering-position, with given tolerances.

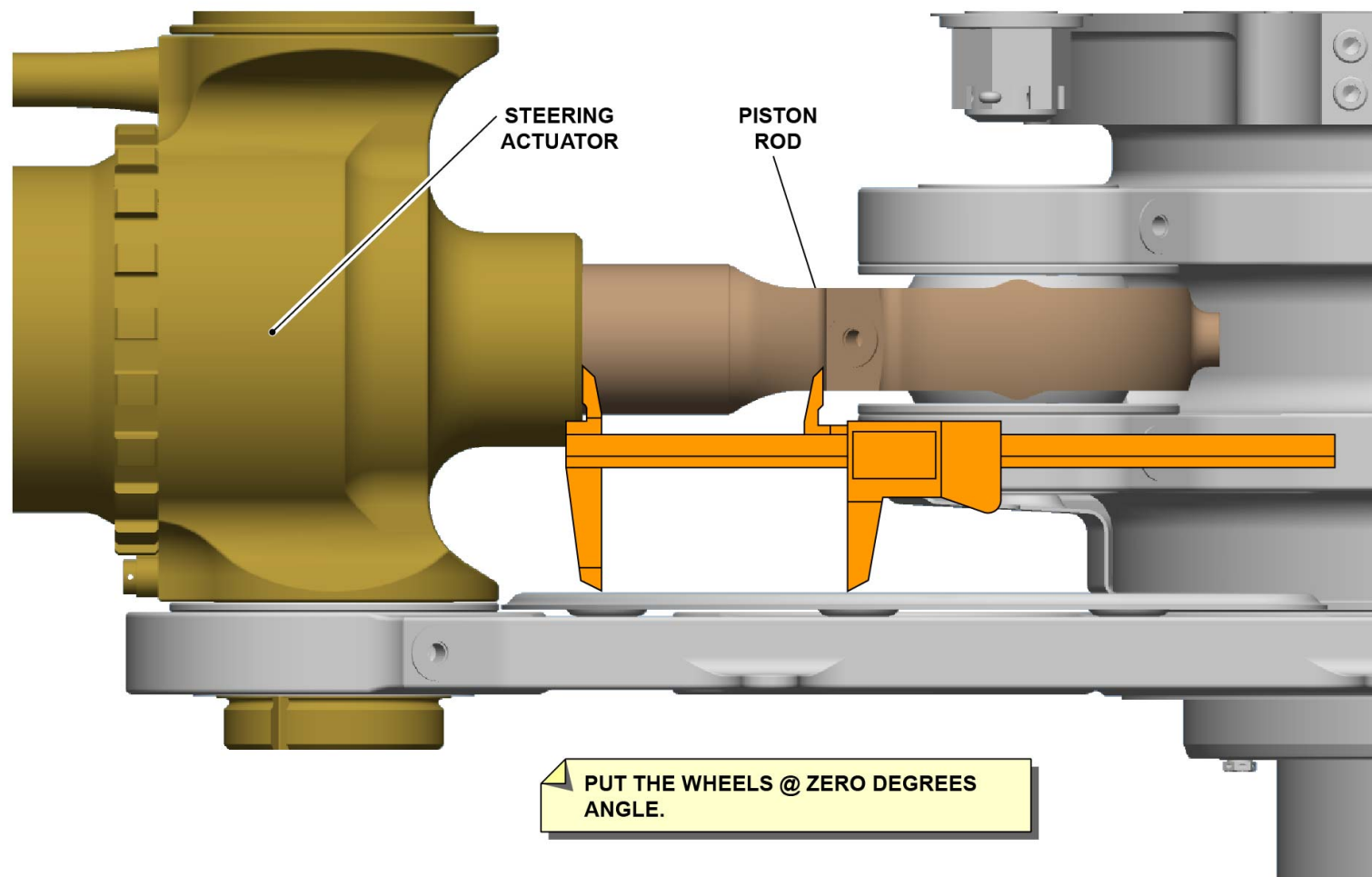

V1813401 - V01T0M0 - VM32M2STEER3001

NWS RVDT ELECTRICAL ZERO CHECK AND RIGGING - NLG ACTUATOR STROKE MEASUREMENT

NOSE WHEEL STEERING MAINTENANCE (2/3)**NWS RVDT Electrical Zero Check and Rigging (continued)****NLG Centering Cams**

For this, the NLG shock absorber must be fully extended, thus nose A/C jacking is necessary.

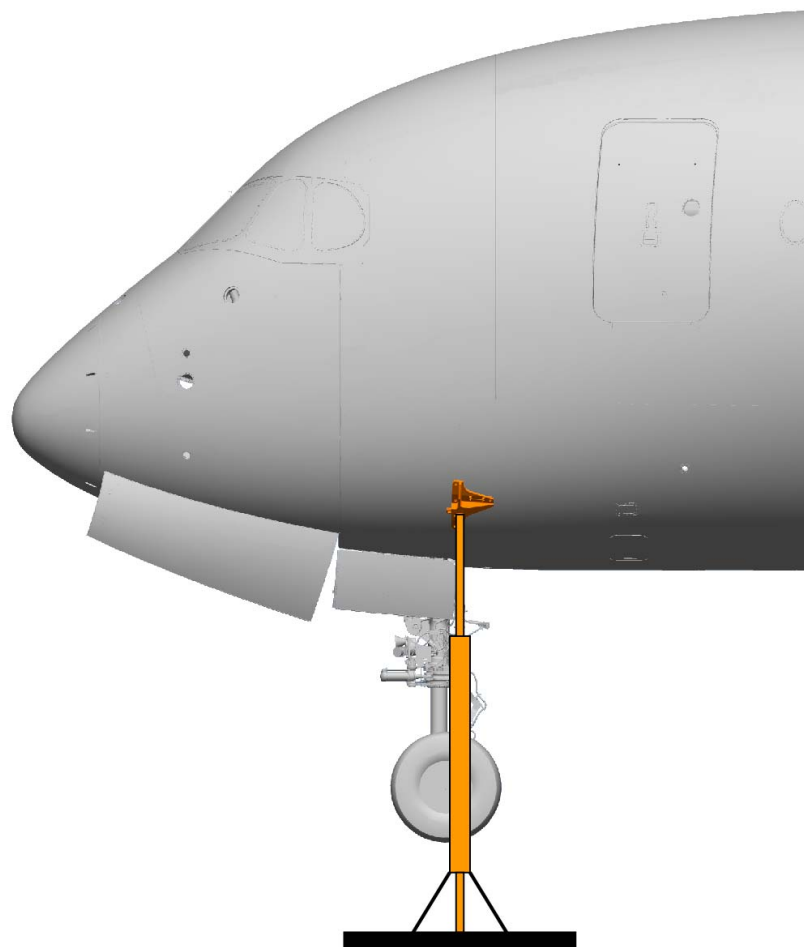

NWS RVDT ELECTRICAL ZERO CHECK AND RIGGING - NLG CENTERING CAMS

V1813401 - V01T0M0 - VM32M2STEER3001

NOSE WHEEL STEERING MAINTENANCE (2/3)

RVDT Value Check

When the NLG is physically at "ZERO", it is possible to read the RVDT value on the OMT. The ATA 32 Nose Wheel Steering (NWS) Aircraft Condition Monitoring System (ACMS) - real time monitoring menu gives the output value of the RVDTs.

AIRCRAFT CONTROL DOMAIN

PARAMETER REAL-TIME MONITORING

Dataset: <105> ATA 32 - NWS

Add:

Toolbar:

Numeric

Tiller Angle CAPT (deg) F/O	Pedal Angle (deg)	59
1 2		
Nose Wheel Steering		
SIDE 1 SIDE 2		
Normal Selector Valve	3	4
NWS Pressure (bar)	7	8
Demanded Angle (deg)	9	10
RVDT Angle (deg)	11	12
Servo Valve Current (mA)	13	14
Servo Valve LVDT Current (mA)	15	16

RVDT VALUE CHECK

V1813401 - V01T0M0 - VM32M2STEER3001

NOSE WHEEL STEERING MAINTENANCE (2/3)

RVDT Rigging

Each RVDT is adjustable with a screwdriver. In relation to the value, the screw installed on the RVDT is turned clockwise or counterclockwise.

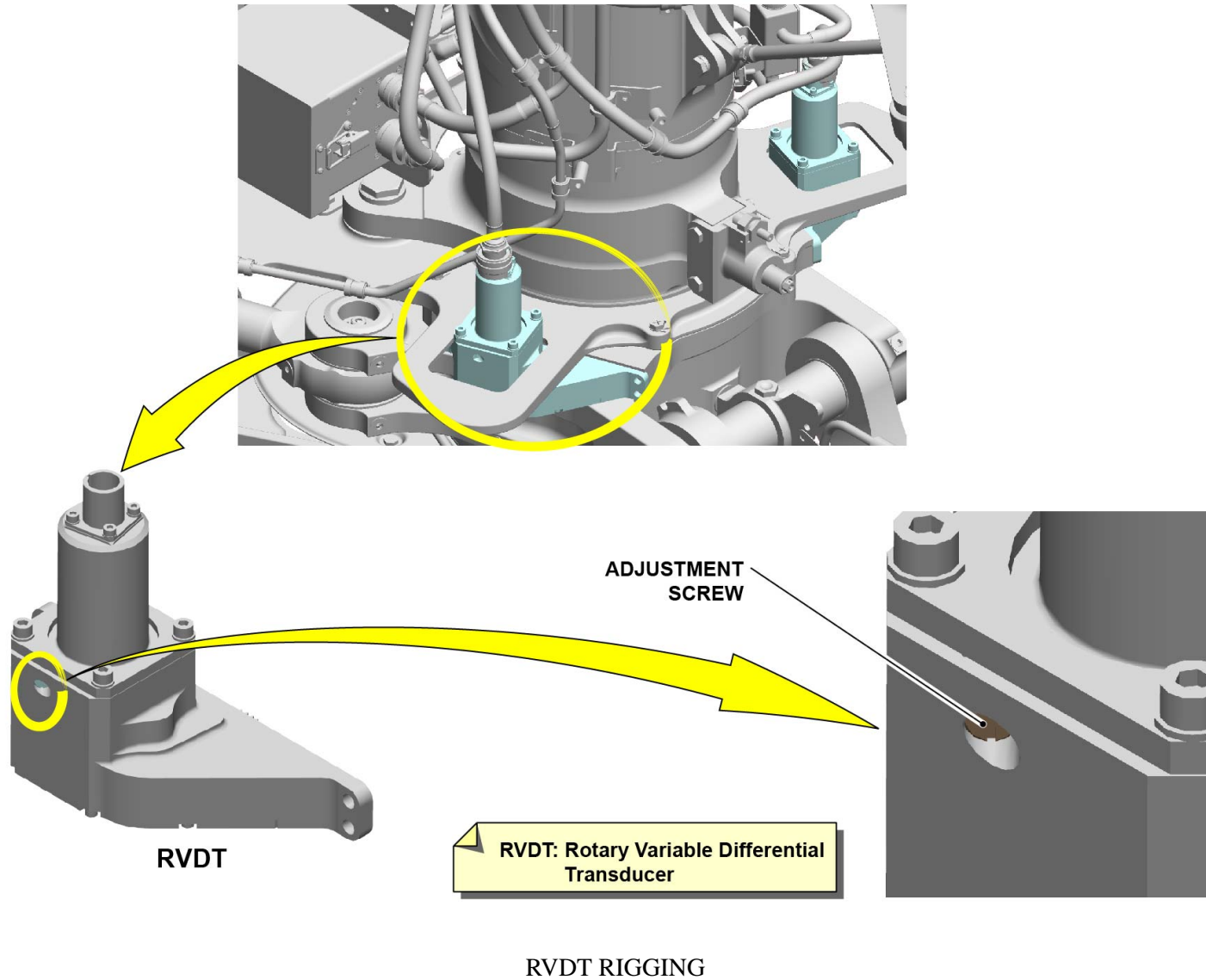

V1813401 - V01T0M0 - VM32M2STEER3001

NOSE WHEEL STEERING CONTROL AND INDICATING (2)

Nose Wheel Steering - General (2)

The control for the nose wheel steering system can be made manually or automatically.

-Manually is made through the Steering Hand Wheels or the Rudder Pedals.

-Automatically it receives signals from the autopilot.

The NWS can be de-activated (for towing or pushback purposes) when a pin is inserted in the steering disconnect panel tow switch.

Indications are displayed on the ECAM wheel page and the NLG Steering Disconnect Panel.

Hand Wheel and Rudder Pedals (2)

The control of the steering system is made by the Wheel Steering Control System (WSCS).

To operate the Nose Wheel Steering system it is necessary to be on the ground and to have one of the Engine Master Lever 1 or 2 to ON and the yellow HP system pressurized.

Two hand wheels, one at the CAPT side and one at the F/O side, send inputs to turn the nose wheels to left or to the right (up to 72 degrees).

When the hand-wheel is turned in a counterclockwise direction, the nose wheels turn to the left. When the hand-wheel is turned in a clockwise direction, the nose wheels turn to the right.

On the ECAM Wheel page, there no indications that show the NLG movement.

On the ECAM Wheel page, a green color symbol near the NLG is indicated when the NWS is available and in amber when the NWS is unavailable.

The two rudder pedal assemblies, one at the CAPT side and the other one at the F/O side are mechanically connected together. The rudder pedals also send steering signals through the flight control computers. A NWS deflection is possible (up to 6 degrees).

Each hand wheel includes a P/BSW identified as "PEDAL DISC", which can isolate the steering system from the rudder pedals inputs.

During Taxi, the pilot can test the rudder system with the rudder pedals. By pushing on the pedal disconnect button, the pilot prevent rudder pedal input to the WSCS, keeping the A/C straight.

For more information, when the MORE keys is depressed on the ECAM Control Panel, the ECAM wheel page displays the STEER CTL 1, 2 channels status (normal in green and inoperative in amber).

Nose Wheel Steering Disconnection Box (2)

The steering disconnection panel is installed on the Nose Landing Gear (NLG).

This box has a towing switch where a pin is inserted for pushback and towing operations. With the pin inserted, a green "NWS disconnect" light is illuminated on the NLG steering disconnection panel. In this configuration the NWS is inhibited.

NWS STEER DISC message is displayed on the warning display when the pin is inserted.

Oversteering Indication (2)

In case of an over steering (above 78 degrees), a message on the WD is displayed. A flashing amber light is also illuminated in amber on the steering disconnect panel.

Mechanical brackets, located on the NLG, break when the over steering exceedance has been reached.

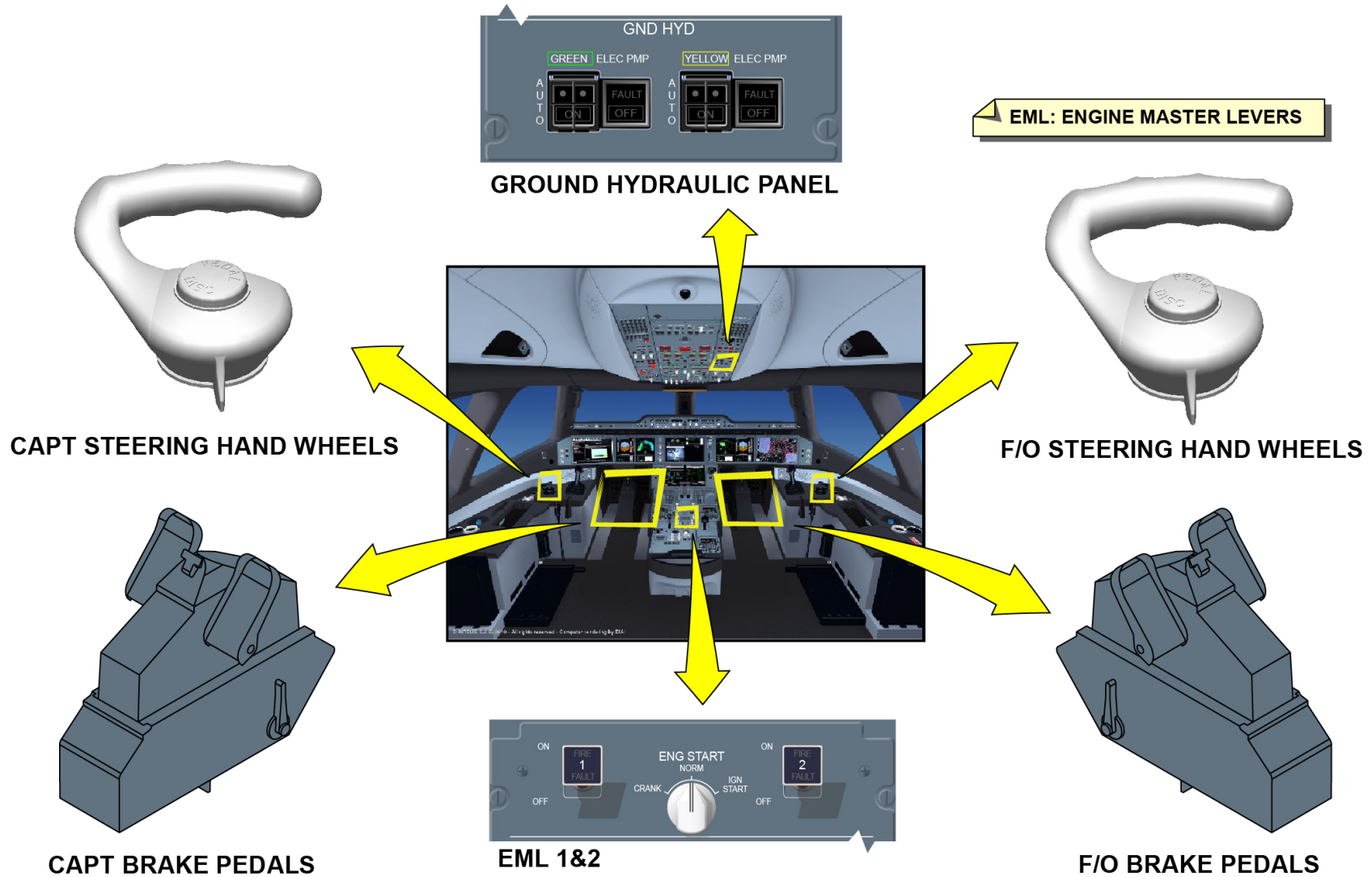

NOSE WHEEL STEERING - GENERAL (2) ... OVERSTEERING INDICATION (2)

V1813401 - V01T0M0 - VM3215STEER2301

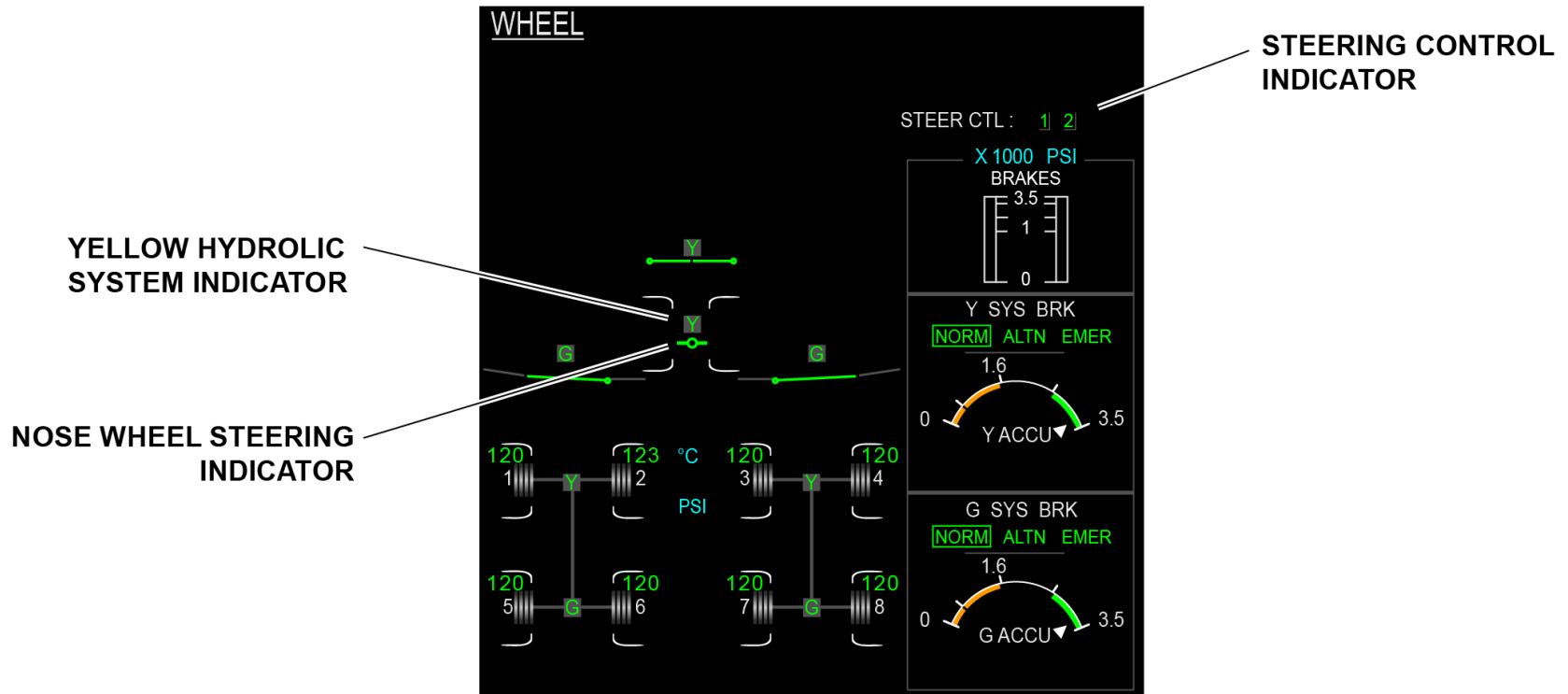

INDICATION	CONDITION
	THE SYSTEM IS NORMAL
	THE SYSTEM IS FAILED
STEER CTL : 1 2	THE TWO SIDES ARE VALID
STEER CTL : 1 X	ONE OF THE TWO SIDES IS INVALID
STEER CTL : X X	THE TWO SIDES ARE INVALID

NOTE: NOT ALL WARNING WILL BE SHOWN AT THE SAME TIME

NOSE WHEEL STEERING - GENERAL (2) ... OVERSTEERING INDICATION (2)

V1813401 - V01T0M0 - VM3215STEER2301

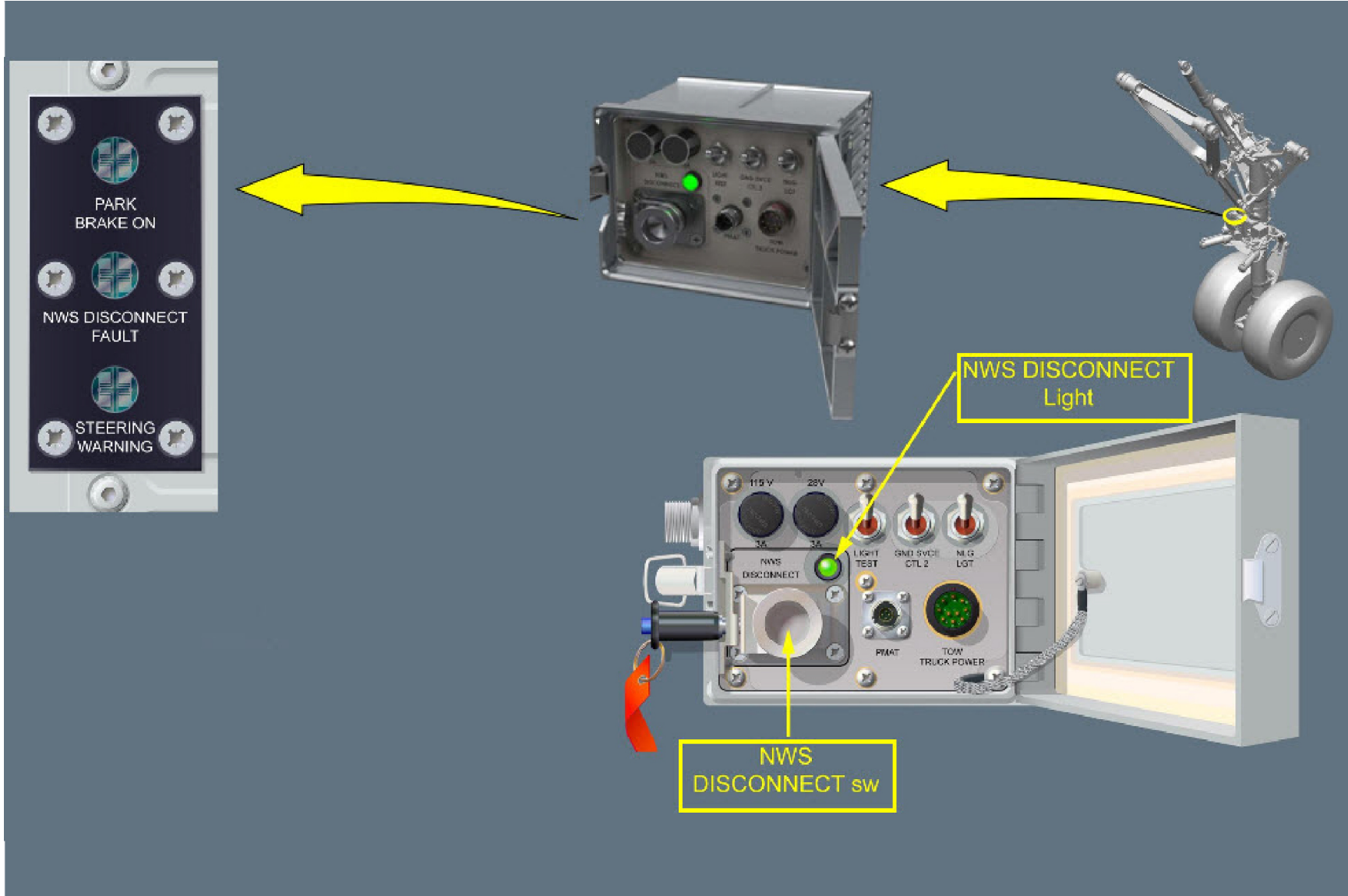

NOSE WHEEL STEERING - GENERAL (2) ... OVERSTEERING INDICATION (2)

V1813401 - V01T0M0 - VM3215STEER2301

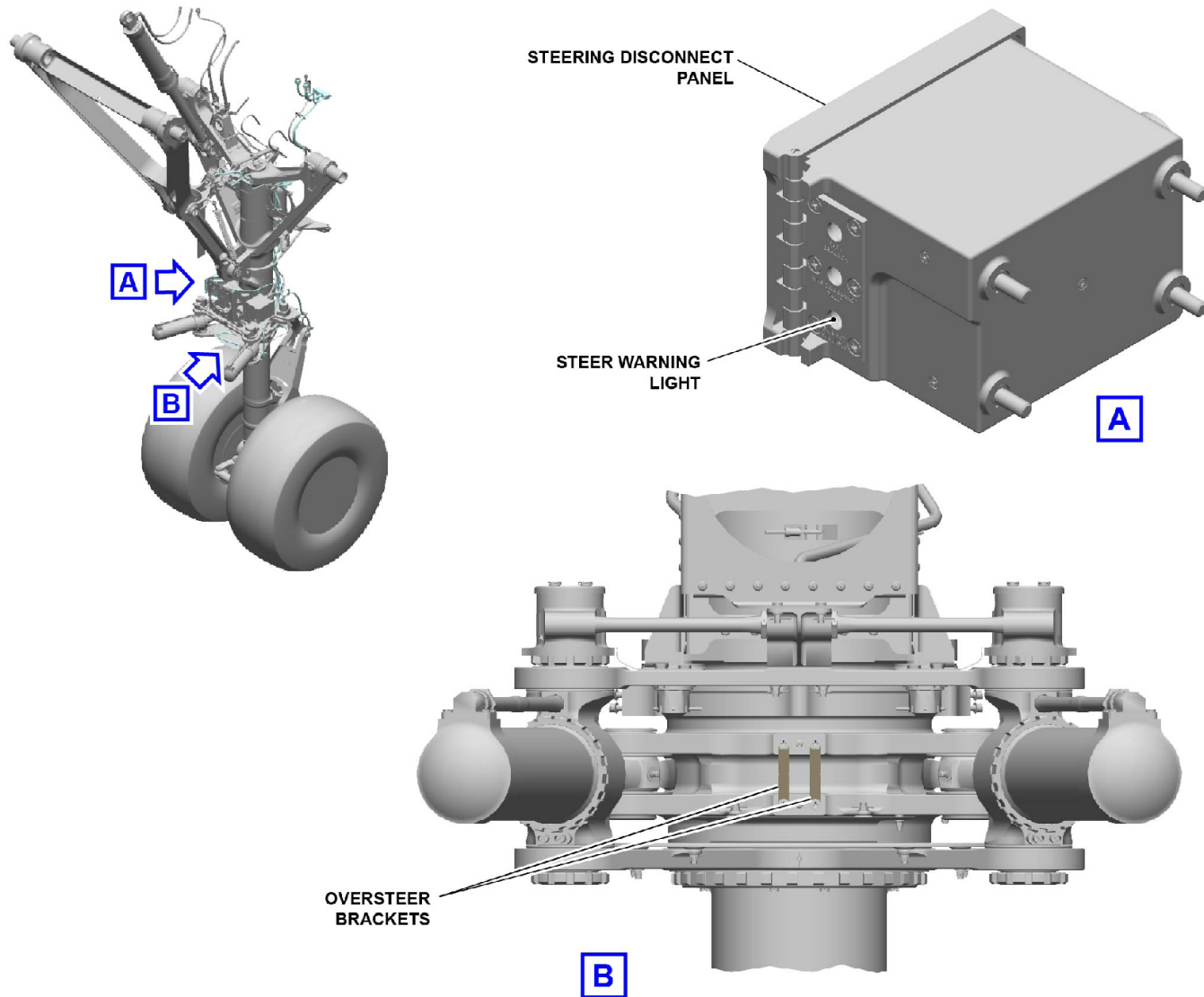

NOSE WHEEL STEERING - GENERAL (2) ... OVERSTEERING INDICATION (2)

V1813401 - V01T0M0 - VM3215STEER2301

This Page Intentionally Left Blank

NOSE WHEEL STEERING CONTROL AND INDICATING (3)

Hand Wheel Control and Rudder Pedals (3)

The control of the steering system is made by the Wheel Steering Control System (WSCS).

To operate the Nose Wheel Steering system it is necessary to be on the ground and to have one of the Engine Master Lever 1 or 2 to ON and the yellow HP system pressurized.

Two hand wheels, one at the CAPT side and one at the F/O side, send inputs to turn the nose wheels to left or to the right (up to 72 degrees). When the hand-wheel is turned in a counterclockwise direction, the nose wheels turn to the left. When the hand-wheel is turned in a clockwise direction, the nose wheels turn to the right.

On the ECAM Wheel page, there no indications that show the NLG movement.

On the ECAM Wheel page, a green color symbol near the NLG is indicated when the NWS is available and in amber when the NWS is unavailable.

For more information, when the MORE keys is depressed on the ECAM Control Panel, the ECAM wheel page displays the STEER CTL 1, 2 channels status (normal in green and inoperative in amber).

The rudder pedals also send steering signals through the flight control computers. A NWS deflection is possible (up to 6 degrees).

Each hand wheel includes a P/BSW identified as "PEDAL DISC", which can isolate the steering system from the rudder pedals inputs.

During Taxi the pilot can test the rudder with the rudder pedals. By pushing on the pedal disconnect button, the pilot prevent rudder pedal input to the WSCS, keeping the A/C straight.

Automatic Differential Braking (3)

In case of the yellow HP hydraulic failure or a NWS specific failure, a back-up steering is available.

If the normal NWS is not available or failed, a N/W STEER symbol is amber on the wheel page.

For more information, when the MORE keys is depressed on the ECAM Control Panel, the ECAM wheel page displays the STEER CTL 1, 2 channels status (normal in green and inoperative in amber).

The Automatic Differential Braking function uses the aft wheel group (5 to 8) pressurized by the green HP system. The ADB function is available when the aft wheel group (5 to 8) is in Normal Braking Mode.

The hand wheels send signals to the CPIOMs WSCS application and are used by the Braking Control System to command brake application.

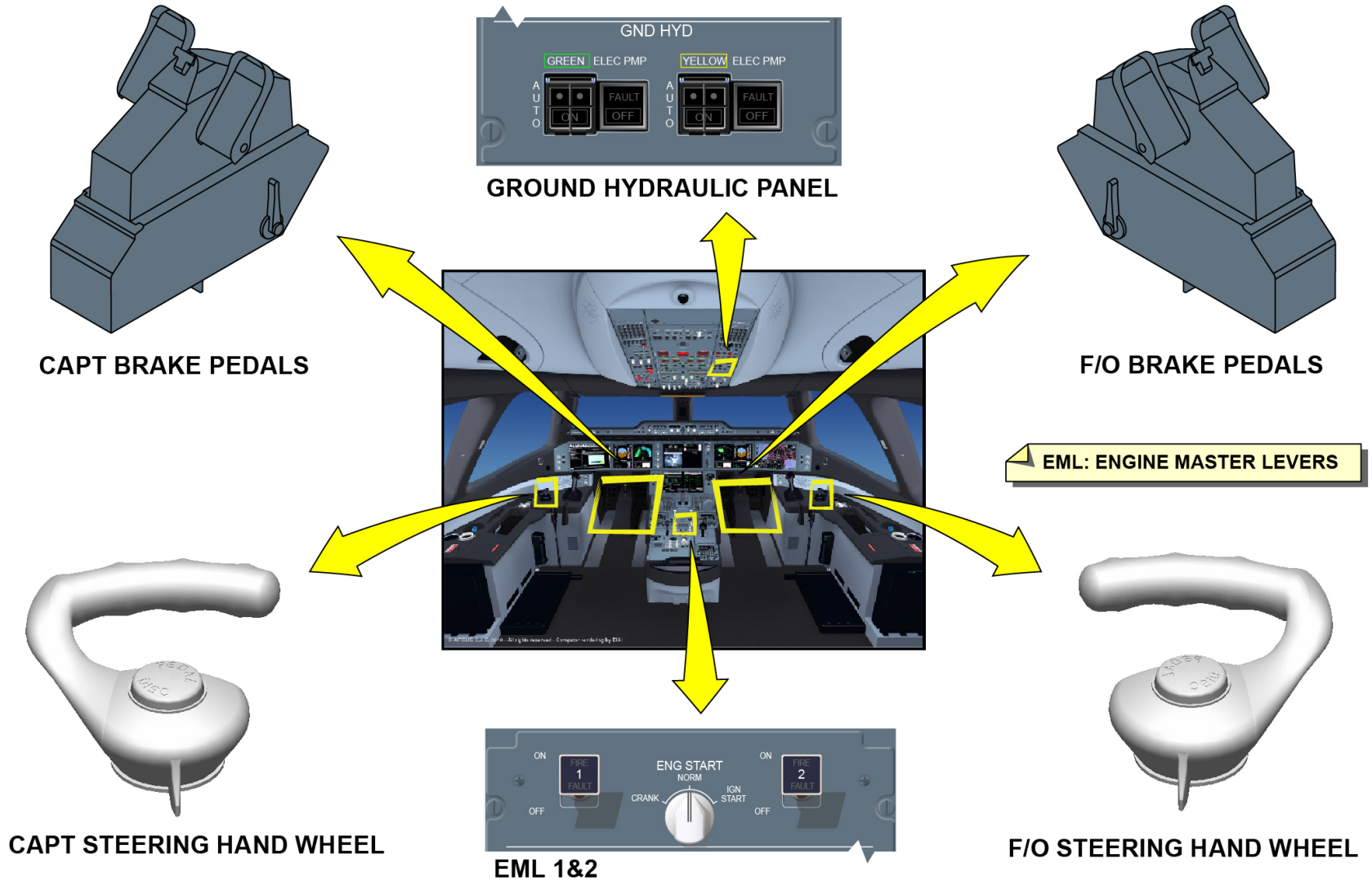

HAND WHEEL CONTROL AND RUDDER PEDALS (3) & AUTOMATIC DIFFERENTIAL BRAKING (3)

V1813401 - V01T0M0 - VM3216STEER3001

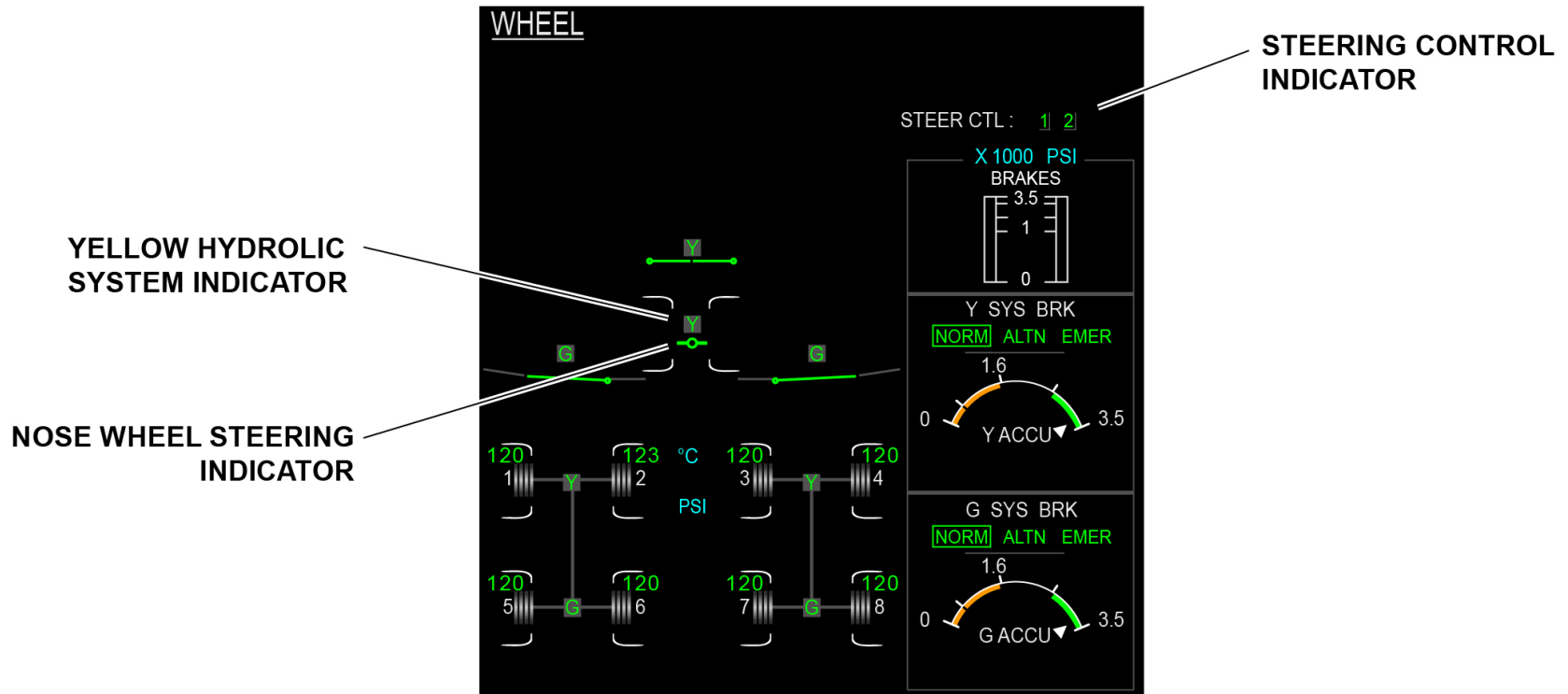

INDICATION	CONDITION
	THE SYSTEM IS NORMAL
	THE SYSTEM IS FAILED
STEER CTL : 1 2	THE TWO SIDES ARE VALID
STEER CTL : 1 X	ONE OF THE TWO SIDES IS INVALID
STEER CTL : X X	THE TWO SIDES ARE INVALID

NOTE: NOT ALL WARNING WILL BE SHOWN AT THE SAME TIME

HAND WHEEL CONTROL AND RUDDER PEDALS (3) & AUTOMATIC DIFFERENTIAL BRAKING (3)

V1813401 - V01T0M0 - VM3216STEER3001

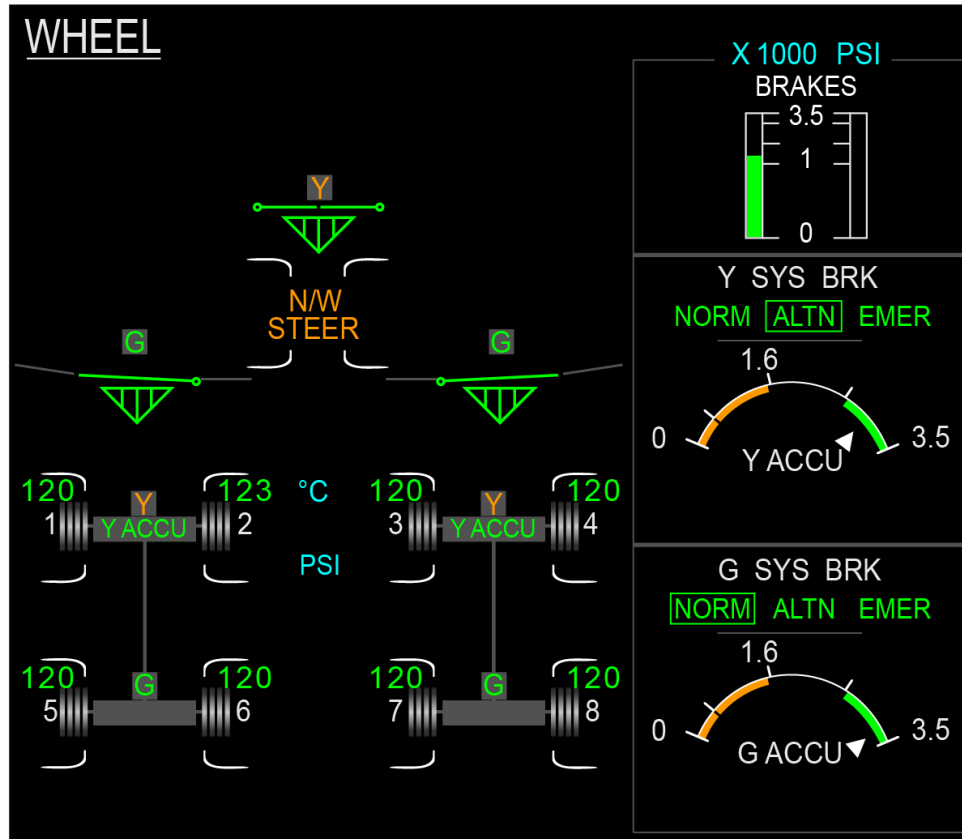

WHEEL SD PAGE

HAND WHEEL CONTROL AND RUDDER PEDALS (3) & AUTOMATIC DIFFERENTIAL BRAKING (3)

V1813401 - V01T0M0 - VM3216STEER3001

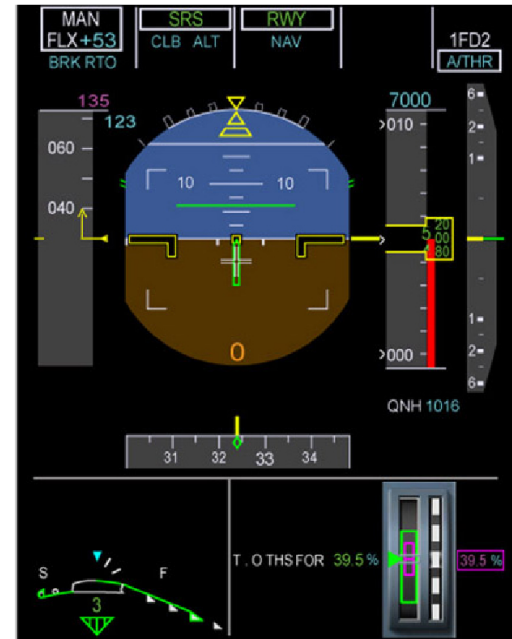

PFD

PFD: Primary Flight Display

HAND WHEEL CONTROL AND RUDDER PEDALS (3) & AUTOMATIC DIFFERENTIAL BRAKING (3)

V1813401 - V01T0M0 - VM3216STEER3001

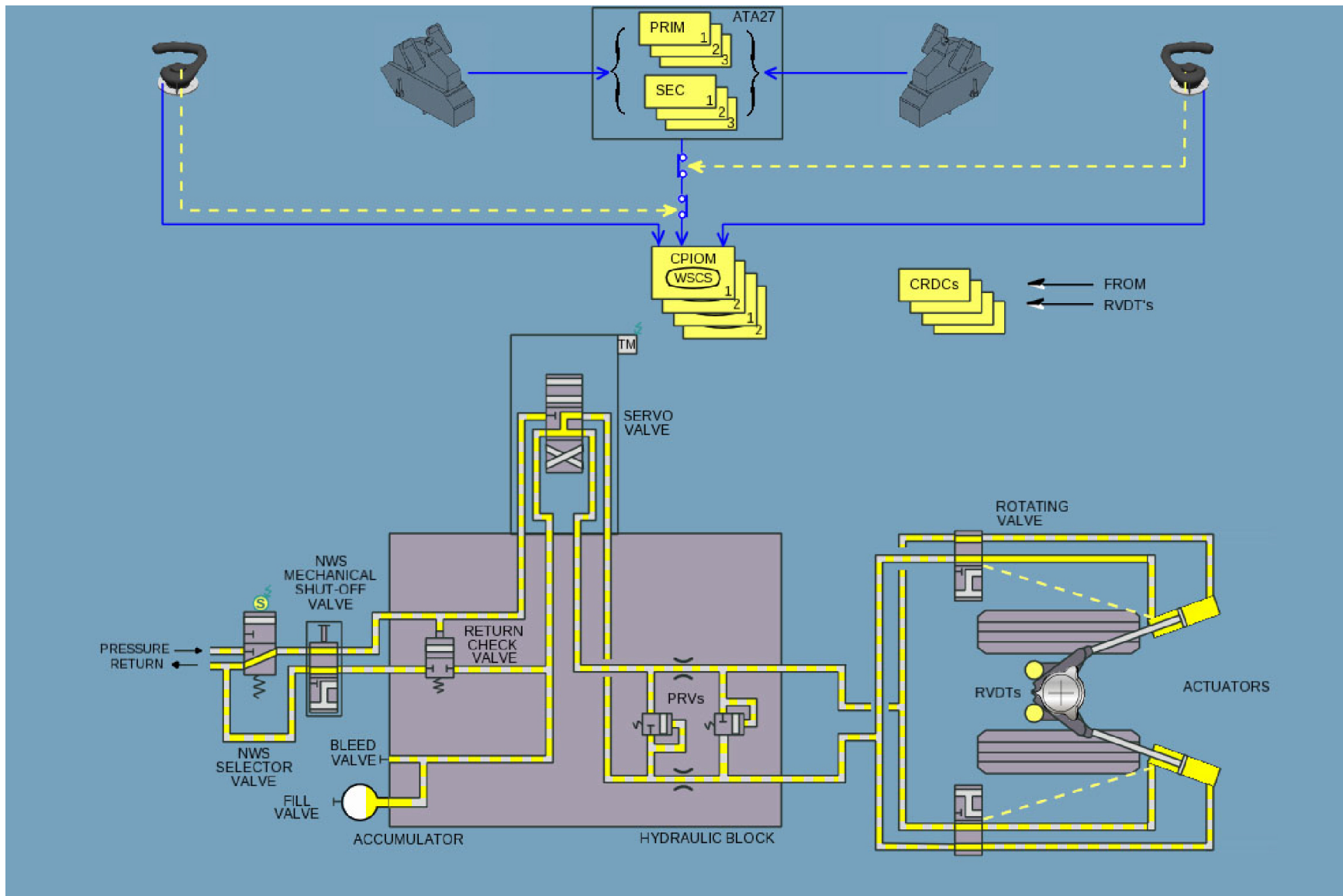

HAND WHEEL CONTROL AND RUDDER PEDALS (3) & AUTOMATIC DIFFERENTIAL BRAKING (3)

V1813401 - V01T0M0 - VM3216STEER3001

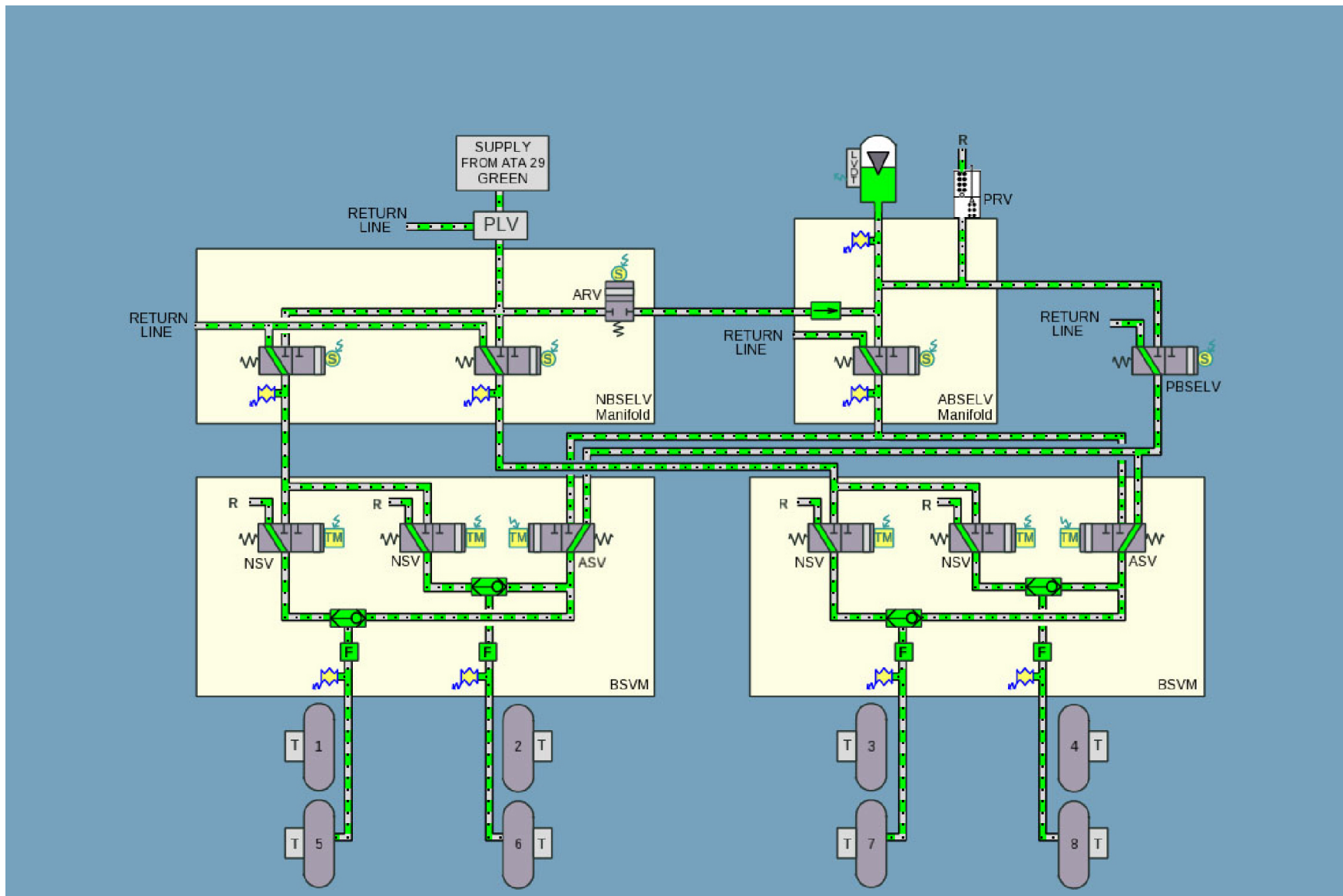

HAND WHEEL CONTROL AND RUDDER PEDALS (3) & AUTOMATIC DIFFERENTIAL BRAKING (3)

V1813401 - V01T0M0 - VM3216STEER3001

This Page Intentionally Left Blank



AIRBUS
AN EADS COMPANY

*AIRBUS S.A.S.
31707 BLAGNAC cedex, FRANCE
STM
REFERENCE V1813401
OCTOBER 2013
PRINTED IN FRANCE
AIRBUS S.A.S. 2013
ALL RIGHTS RESERVED*

AN EADS COMPANY