

**A350**  
**TECHNICAL TRAINING MANUAL**  
**MAINTENANCE COURSE - T1+T2 - RR Trent XWB**  
**Fuel**



This document must be used for training purposes only

Under no circumstances should this document be used as a reference

It will not be updated.

All rights reserved

No part of this manual may be reproduced in any form,  
by photostat, microfilm, retrieval system, or any other means,  
without the prior written permission of AIRBUS S.A.S.



AIRBUS Environmental Recommendation

Please consider your environmental responsibility before printing this document.



**FUEL**

Fuel Tank Safety Procedures (2) . . . . .	2
Tanks and Water Drainage System Description (2/3) . . . . .	42
Fuel Tank Venting System Description (2/3) . . . . .	48
Fuel Quantity Management System Description (2/3) . . . . .	50
Engine Feed System Description (2/3) . . . . .	60
APU Feed System Description (2/3) . . . . .	76
Refuel/Defuel/Transfer System Description (2/3) . . . . .	82
Jettison System Description (2/3) . . . . .	90
Fuel System Control and Indicating (2/3) . . . . .	96

## FUEL TANK SAFETY PROCEDURES (2)

### General

After three fuel tank explosions in recent decades, which caused 346 deaths, the U.S Department of Transportation, Federal Aviation Administration (FAA), started a new regulation to get better fuel tank safety.

This regulation is related to the prevention of ignition sources in fuel tanks of current type certificated aircraft. It requires a one-time fuel system safety and design review of the aircraft.

### **Critical Design Configuration Control Limitations (CDCCL)**

The FAA issued Special Federal Aviation Regulation (SFAR) 88 which gives a detailed description of the CDCCL concept.

The DGAC requested the SFAR 88 to be added to PART 145, PART M and PART 147 to reinforce the application of these regulations.

This includes:

- a conception part related to aircraft design characteristics,
- a maintenance part.

A CDCCL is a limitation requirement to keep a critical ignition source prevention characteristic of the fuel system design that is necessary to prevent the occurrence of a dangerous condition.

The function of the CDCCL is to give instructions to keep the critical ignition source prevention characteristic during a configuration change that can be caused by alterations, repairs or maintenance actions.

The aircraft manufacturers must supply a document to their customers that gives the list of all the maintenance tasks related to the CDCCL.

For AIRBUS, this document is called the Fuel Airworthiness Limitations and it is added to the Airworthiness Limitation Section part 5.

CRITICAL DESIGN CONFIGURATION CONTROL LIMITATIONS (CDCCL)

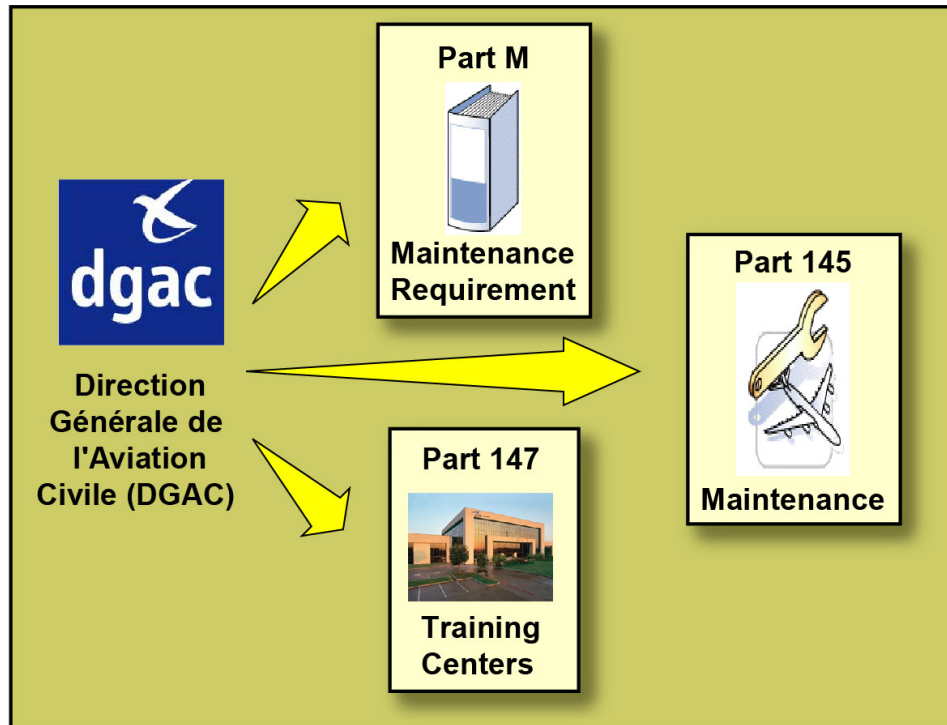
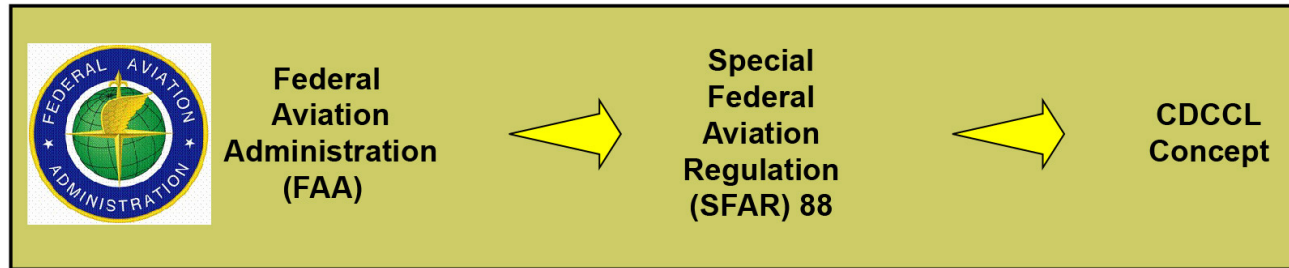

A CDCCL is a limitation requirement to keep a critical ignition source prevention characteristic of the fuel system design that is necessary to prevent the occurrence of a dangerous condition.

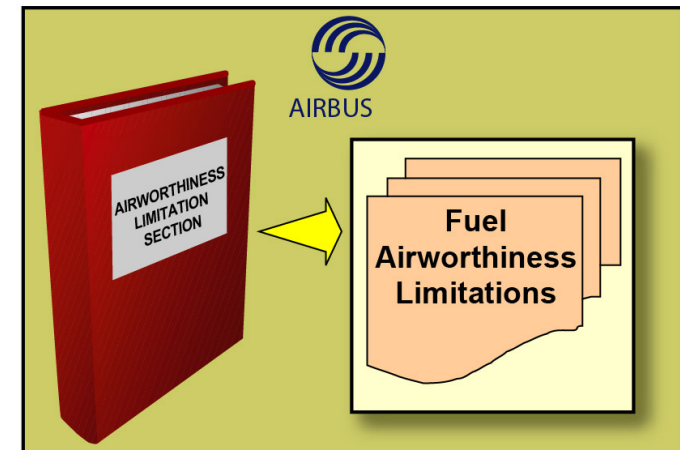

GENERAL - CRITICAL DESIGN CONFIGURATION CONTROL LIMITATIONS (CDCCL)

V1813401 - V01T0M0 - XM28D1000000001

## FUEL TANK SAFETY PROCEDURES (2)

### General (continued)

#### Fuel Information and Combustion Triangle

A fuel tank can be viewed as a confined space where under specific conditions of pressure and temperature the ullage (vacant tank space) can be made of an evaporated fuel/air mixture known as fuel vapor. The liquid fuel does not blow up on its own; explosive conditions are created when specific proportions of evaporated fuel, oxygen, pressure and temperature are present in the tank ullage; the fuel vapor is then defined as flammable. Even if the ullage is flammable, an explosion will not occur unless an ignition source of sufficient energy exists.

The combustion triangle:

An Explosion in a "Fuel" environment such as aircraft wing tanks can only occur if the 3 following sources are reached:

- fuel vapors,
- air (Oxygen O<sub>2</sub>),
- ignition (Electrical short cut, cigarette, etc.).

The aircraft fuel system has, by design, a number of features that are intended to protect the system from inadvertent ignition.

The potential sources of ignition considered are:

- spark generation inside a fuel tank by electrical current originated from external sources such as a lightning strike on the aircraft, by wiring or equipment electrical faults,
- spark/heat generation inside a fuel tank caused by friction of moving parts,
- fuel leakage outside of a fuel tank coming into contact with an ignition source.

A chart shows the fuel grades used.

The flash point is the lowest temperature at which the liquid supplies enough vapors mixed with ambient air, to make a gas that will ignite with the contact of a thermal source, also called flame.

At this temperature the combustion will not be self sufficient, because you need to reach the ignition point.

If the ignition does not need a flame, we talk about auto-ignition.

The Auto-Ignition point is the temperature at which a gas or a vapor ignites spontaneously in the absence of a thermal source.

Do not confuse this term with the ignition point (temperature at which the combustion is started and can continue).



COUNTRY	ORGANISATION	GRADE DESIGNATION
—	IATA	KEROSENE
US	ASTM DOD	JET A, JET A1 JP 8 JP 5
UK	MOD	AVTUR AVCAT TS - 1, RT
CHINA	PRC MPIS	No. 3 JET FUEL (RP 3)

JET A CHARACTERISTICS	
Color	Colorless to yellow
Freeze temperature	< - 47°C
Density	From 0,775 to 0,840
Flash point	Minimum 38°C at sea level 7°C at 12000 m
Self ignition temperature	>230°C

**Flash point :**  
The flash point is the lowest temperature at which the liquid supplies enough vapors mixed with ambient air, to make a gas that will ignite with the contact of a thermal source (flame).

**Ignition**

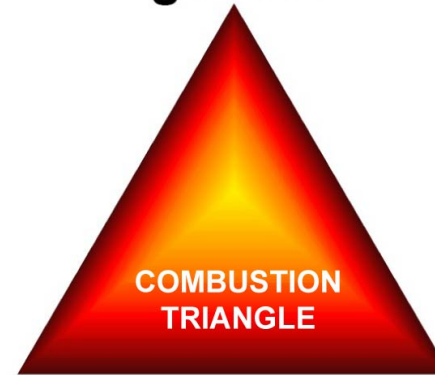

**Oxygen**

**Fuel**

**Auto-ignition point :**  
the temperature at which a gas or a vapor ignites spontaneously in the absence of a thermal source.

GENERAL - FUEL INFORMATION AND COMBUSTION TRIANGLE

V1813401 - V01T0M0 - XM28D1000000001

## FUEL TANK SAFETY PROCEDURES (2)

### Fuel System Design Configuration

The Airbus aircraft fuel systems have, by design, a number of features that are intended to protect the system from inadvertent ignition.

#### - Wing / Trim Tank Structure:

In all the fuel tanks, the material and the large number of fasteners on the attachment of the metallic structure used make sure that the fuel tank structures are electrically bonded.

Composite ribs are bonded by means of metallic strips attached to the non-metallic structure.

All aluminum structural items in the wing, trim and centre boxes have a finishing for protection against electrical harnesses short-circuit with the structure.

The combination of the construction and thickness of the tank boundary skins give protection against a lightning strike causing ignition (heat).

#### - Fuel Quantity Indicating (FQI) Equipment:

Probes and sensors installed in tanks have low power supply. Electrical connection is done through a terminal block. The protective gap between the probes and the tank structure is maintained. They are electrically isolated from the structure.

#### - Fuel pump:

Fuel pumps have safety features to prevent pumps from working in an empty fuel tank. The pumps are tested to show that even after a long working condition in an "empty fuel tank" the rotating surfaces remain lubricated and thus limit the risk of mechanical ignition.

Each of the pumps is contained within an explosion-proof canister. It comprises a pump element contained within and electrically bonded to the canister and driven by an electric motor. Electrical connections to all pumps are made outside the tank.

The moving parts inside the pump are normally submerged in fuel so they cannot generate a spark during faulty conditions.

#### - Lightning Protection:

All equipment installed within any fuel tank is bonded to the structure

#### - Fuel System Wiring:

Only when absolutely necessary, wiring is routed inside fuel tanks. This wiring is limited to sensing and monitoring systems, with very low energy carrying requirements, to protect against the occurrence of an ignition source as a result of high energy entering the fuel tank via the wiring. External electrical wiring support clamps make sure, that a cut cable cannot come into contact with the fuel tank boundary or structure in a fuel vapor area.

There is a complete segregation between in-tank wiring equipment and fuel calculators from other aircraft system wirings.

#### - Valves:

All motor operated valves within the fuel tanks have the actuator located outside the tank wall. The valve mechanisms inside the tank are dual bonded and do not have an ignition hazard.

#### - Pressure Switches:

Pump pressure switches are mounted on the tank boundaries. They are separated from the fuel by a diaphragm. The electrical connections are fully sealed and explosion proof.

#### - Fuel Leaks:

It is possible for fuel or fuel vapor to leak from a fuel tank into an adjacent area and the accumulated fuel can become hazardous causing ignition. Fuel leaks from the wing and trim tanks go either to the leading or trailing edge cavities or to the outside. Any fuel overflowing from the NACA intake is directed downwards and away from the engines (heat source) via a fuel leak drip strip (angle section) located inboard of the NACA intake. In the leading and trailing edges the equipment is explosion proofed and insulated from the leakage. The APU fuel feed and Trim Tank transfer pipes at the rear fuselage are shrouded so any fuel leakage is drained overboard via the drain mast.

#### - Heat Sources:

Wing leading edges contain hot air ducting from the engines to the bleed air and anti icing systems. These pipes are insulated and separated from the tank boundary.



Electrical harnesses in the tanks use very low voltage current (less than 5 VDC) and are far enough for the surrounding equipment and structure (segregated routing).



Fuel pumps are the only electrical equipment using high power current (115 VAC). Consequently, pumps harnesses are located under the lower wing skin panels outside the fuel tanks.

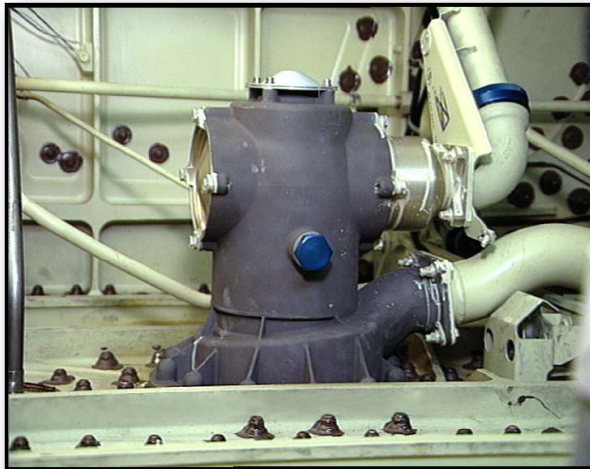

Fuel pumps are installed in a self-contained explosive canister.

### FUEL SYSTEM DESIGN CONFIGURATION

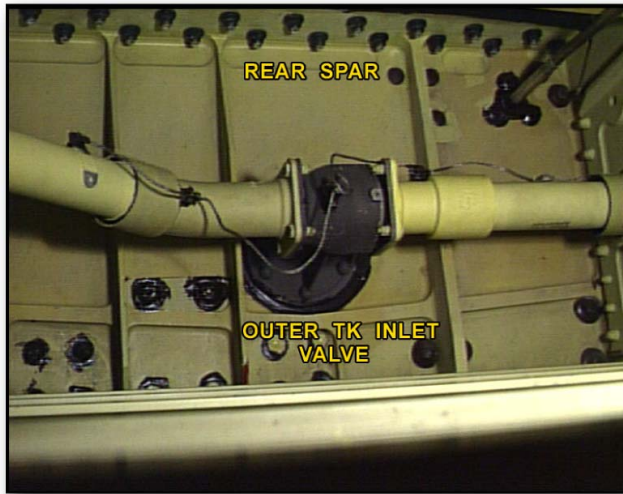

Bonded valve inside the tank

Insulated hot air duct and Valve actuator located outside of the tank

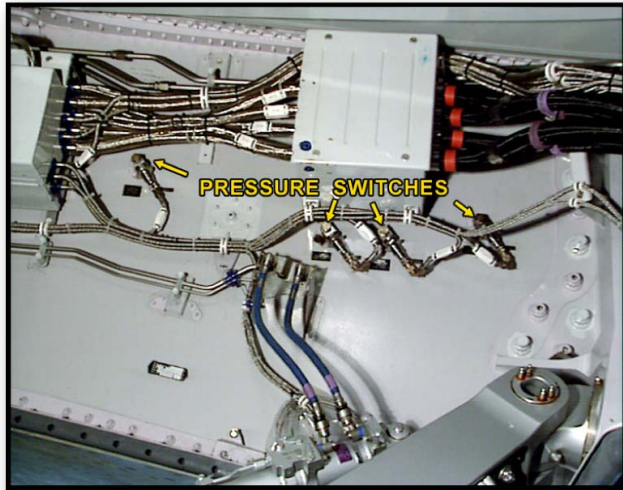

Pressure Switches and FQI terminal block

Wing fence and Naca air intake



**FUEL SYSTEM DESIGN CONFIGURATION**

V1813401 - V01T0M0 - XM28D1000000001

This Page Intentionally Left Blank

V1813401 - V01T0M0 - XM28D1000000001

## FUEL TANK SAFETY PROCEDURES (2)

### **Maintenance Application of CDCCL**

CDCCL items are listed in Airworthiness Limitation Form.  
CDCCL section 2 of Airworthiness Limitation Form.



Customer Services Directorate

## A330 Fuel Airworthiness Limitations

### SECTION 0 - INTRODUCTION

#### 1. **SCOPE**

This document contains the Fuel Airworthiness Limitations that arise from compliance with JAA's Interim Policy on Fuel Tank Safety (INT/POL/25/12) and FAA's Special Federal Aviation Regulation (SFAR) 88. They have been derived in accordance with JAA's draft Temporary Guidance Leaflet (TGL) 47 and FAA's Advisory Circular (AC) 25.981-1B. The nomenclature and means of promulgation follow the FAA's memorandum ref PS-ANM100-2004-10029 'Policy Statement on Process for Developing SFAR 88-related Instructions for Maintenance and Inspection of Fuel Tank Systems'. This latter document has been jointly developed between FAA and JAA to ensure a unified approach.

These requirements, together with the Life Limits / Monitored Parts, structural Airworthiness Limitation Items (ALI) and systems Certification Maintenance Requirements (CMR) comprise the Airworthiness Limitation Section which satisfies the requirements of JAR 25.1529 Appendix H paragraph 25.4.

**IMPORTANT:** At first delivery of an aircraft configuration into an operator's fleet, the requirements given in this document are mandatory, except in so far that interval escalations can be justified in accordance with the procedure stated herein. If a more restrictive Fuel ALI is issued on an aircraft configuration already in service, the requirement for existing operators to follow the revised FAL document will normally be mandated by Airworthiness Directive (Consigne de Navigabilité).

Non-compliance suspends the validity of the Airworthiness Certificate.

The identification of Fuel Airworthiness Limitations in no way diminishes the importance of other tasks and practices associated with the fuel system. Changes to these are subject to normal practices and procedures between the operator and his national authorities.

This document does not take into account Airworthiness Directives (Consigne de Navigabilité) which, if issued against an existing Fuel Airworthiness Limitation, supersede the specific requirement given in this document

### MAINTENANCE APPLICATION OF CDCCL



Customer Services Directorate

A330 Fuel Airworthiness Limitations

SECTION 2

CRITICAL DESIGN CONFIGURATION CONTROL LIMITATIONS

CDCCL	Requirement	Reference	Applicability
1	Air gap between a fuel quantity indicating probes and the aircraft structure.  The gap stated in the relevant maintenance procedure in the AMM must be achieved during installation of a fuel quantity probe.	AMM 28-42-15-400 28-42-16-400 28-42-17-400 28-42-19-400 28-42-21-400	ALL A330-200 ALL A330-200 ALL
2	Separation of fuel quantity and level indicating system wiring from other wiring.  To prevent cross coupling of high voltage transients and thereby keep unsafe ignition energies from inside the tank it is required that operators obey the wire routing and separation standards given in the Electrical Standard Practices Manual (ESPM).	ESPM 20-10-00 20-33-20 20-33-21 20-33-22	ALL ALL ALL
3	Direct bonding on items of equipment inside a fuel tank.  Direct bonding is critical to prevent spark generation during component failure and lightning strike conditions and must not be compromised  Direct bonding in fuel tanks must be carried out during component installation to the appropriate bonding method and standard stated within the installation procedure in the AMM.	AMM 28-11-41-400 28-11-44-400 28-11-45-400 28-11-48-400 28-12-41-400 28-17-51-400 28-21-51-400 28-21-52-400 28-23-43-400 28-26-42-400 28-26-51-400 28-31-41-400  28-42-18-400 28-27-11-400	ALL A330-200 ALL ALL ALL ALL ALL ALL ALL ALL A330-200 A330-200 Post 45008 ALL
4	Safety critical features of fuel pumps  These features must be maintained throughout the full life of the fuel pump to avoid the possibility of generation of an ignition source by overheating or sparks caused by arcing, friction etc.  Repair and overhaul of fuel pumps must be carried out in accordance with the equipment manufacturer's maintenance instructions or other maintenance instructions acceptable to the certifying authority.	CMM 28-20-40 28-21-50	ALL

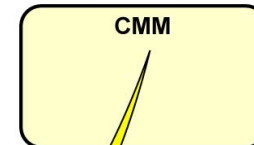
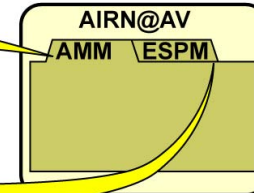
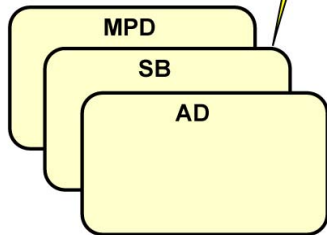

MAINTENANCE APPLICATION OF CDCCL

V1813401 - V01T0M0 - XM28D1000000001



This Page Intentionally Left Blank

V1813401 - V01T0M0 - XM28D1000000001

## FUEL TANK SAFETY PROCEDURES (2)

### Maintenance Application of CDCCL (continued)

#### AMM Application

A WARNING in the procedures identifies CDCCL items. When a procedure identifies a CDCCL item, it is mandatory and necessary that you follow the instructions correctly and accurately.

Air gap between fuel quantity indicating probes and the aircraft structure.

**WARNING: THIS PROCEDURE USES A FUEL SYSTEM ITEM THAT IS IN A CATEGORY KNOWN AS A CRITICAL DESIGN CONFIGURATION CONTROL LIMITATION (CDCCL). CDCCL IDENTIFIES AN ITEM THAT CAN BE THE SOURCE OF A POSSIBLE FUEL TANK IGNITION. YOU MUST KEEP ALL CDCCL ITEMS IN THE APPROVED CONFIGURATION. DAMAGE, WEAR OR CHANGES TO A CDCCL ITEM CAN CAUSE A POSSIBLE FUEL TANK EXPLOSION.**

**WARNING: THIS INSTRUCTION IS APPLICABLE TO A CRITICAL DESIGN CONFIGURATION CONTROL LIMITATION (CDCCL). CAREFULLY OBEY ALL GIVEN INSTRUCTIONS WHEN YOU DO THIS STEP. IF YOU DO NOT OBEY THESE INSTRUCTIONS, A DANGEROUS CONDITION CAN OCCUR THAT CAN CAUSE A POSSIBLE FUEL TANK EXPLOSION.**

The screenshot shows a web browser window titled "AIBF A340 - Selected effectivity: ALL - Document AMM - ADDC N@vigator V 2.4b - Microsoft Internet Explorer provided by AIRBUS". The user is identified as ARROYAS, with a database of AIBF - A340 and a revision date of October 1, 2007. The document is for effectivity ALL. The browser address bar shows "AirN@v / Maintenance".

The main content area displays the following structure:

- 28 - FUEL**
- 28-00 - FUEL - GENERAL**
- 28-00-00 - FUEL - GENERAL**
- 28-00-00 PB 001 - FUEL - GENERAL - DESCRIPTION AND OPERATION**

The highlighted section contains the following text:

1. General

A. Critical Design Configuration Control Limitations (CDCCL)

Some procedures identify a fuel system item that is in a category known as a Critical Design Configuration Control Limitation (CDCCL). This category is applicable to items that are identified as the possible source of ignition of fuel in a fuel tank. You must keep CDCCL items in a serviceable condition. It is possible that damage, wear or changes to a CDCCL item can cause a fuel tank explosion. CDCCL items are identified by a WARNING in the procedures where they occur. When a procedure identifies a CDCCL item, it is a mandatory requirement that you do the instruction correctly and accurately as the procedure tells you.

B. Description

The fuel system:

- keeps fuel in the main fuel tanks and trim tank, which are open to atmosphere through vent surge tanks
- controls and supplies fuel in the correct quantities to the fuel tanks during refuel operations
- supplies fuel to the engines
- supplies fuel to the Auxiliary Power Unit (APU)
- moves fuel to and from the trim tank (during flight) to control the Center of Gravity (CG) of the aircraft
- supplies fuel to cool the Integrated Drive Generators (IDG)
- contains sufficient fuel to let the aircraft operate at an Extended Range (ER). Thus the aircraft does not have a diversion time limit
- makes it possible to discard some of the aircraft fuel in flight
- keeps fuel in the outer wing to give wing bending and flutter relief
- gives indications in the cockpit of the usual system operation
- gives indications in the cockpit of failures that could cause an unusual condition.

2. Component Location

(Ref. Fig. 001 SHEET 001.1)  
 (Ref. Fig. 002 SHEET 002.1)  
 (Ref. Fig. 003 SHEET 003.1)

MAINTENANCE APPLICATION OF CDCCL - AMM APPLICATION

V1813401 - V01T0M0 - XM28D1000000001

**WARNING: THIS PROCEDURE USES A FUEL SYSTEM ITEM THAT IS IN A CATEGORY KNOWN AS A CRITICAL DESIGN CONFIGURATION CONTROL LIMITATION (CDCCL). CDCCL IDENTIFIES AN ITEM THAT CAN BE THE SOURCE OF A POSSIBLE FUEL TANK IGNITION. YOU MUST KEEP ALL CDCCL ITEMS IN THE APPROVED CONFIGURATION. DAMAGE, WEAR OR CHANGES TO A CDCCL ITEM CAN CAUSE A POSSIBLE FUEL TANK EXPLOSION.**

**WARNING: MAKE SURE THAT THE SAFETY DEVICES AND THE WARNING NOTICES ARE IN POSITION BEFORE YOU START A TASK ON OR NEAR:**

- THE FLIGHT CONTROLS
- THE FLIGHT CONTROL SURFACES
- THE LANDING GEAR AND THE RELATED DOORS
- COMPONENTS THAT MOVE.

**MOVEMENT OF COMPONENTS CAN KILL OR INJURE PERSONS.**

**WARNING: MAKE SURE THAT THE GROUND SAFETY-LOCKS ARE CORRECTLY INSTALLED ON THE LANDING GEAR. THIS PREVENTS UNWANTED MOVEMENT OF THE LANDING GEAR.**

1. Reason for the Job  
Self Explanatory

2. Job Set-up Information

3. Job Set-up  
Subtask 28-42-15-941-051

**WARNING: OBEY THE SAFETY PROCEDURES WHEN YOU DO WORK IN A FUEL TANK. THIS WILL PREVENT INJURY OR DAMAGE.**

A. Safety Precautions

(1) Obey the safety procedures when you do work in a fuel tank [\(Ref. AMM TASK 28-10-00-910-901\)](#).

Subtask 28-42-15-010-052

B. Get Access

(1) Make sure that the adjustable platform is in position below the applicable access panel

(2) Make sure that the applicable access panel is removed.

**WARNING: THIS INSTRUCTION IS APPLICABLE TO A CRITICAL DESIGN CONFIGURATION CONTROL LIMITATION (CDCCL). CAREFULLY OBEY ALL GIVEN INSTRUCTIONS WHEN YOU DO THIS STEP. IF YOU DO NOT OBEY THESE INSTRUCTIONS, A DANGEROUS CONDITION CAN OCCUR THAT CAN CAUSE A POSSIBLE FUEL TANK EXPLOSION.**

(1) Put the probe (10) in the correct position and install the bolts (1).

(a) Measure the clearance between the structure and the top and the bottom of the probe (10). Make sure that there is a minimum of 10 mm (0.3937 in.) clearance at the top and the bottom probe position.

(b) To prevent the possibility of a static discharge, also make sure that the fuel probe is not less than 7 mm (0.2755 in.) from:

- the nearest structure - nb and tank wall
- pipework, brackets, p-clips and fasteners
- other metal parts.

(2) Identify and connect the electrical connectors of the cable (9) with the screws (4), (5) and (6).

(3) TORQUE the screws (4), (5) and (6):

- the screw (4) to 0.11 m.daN (9.73 lbf.in)
- the screw (5)

DESIGNATION	FIN	LOCATION
	3QM1	
	3QM2	
	2QM2	K34
	2QM1	M78
	1QM2	M77
	1QM1	M76

MAINTENANCE APPLICATION OF CDCCL - AMM APPLICATION

This Page Intentionally Left Blank

**FUEL TANK SAFETY PROCEDURES (2)****Maintenance Application of CDCCL (continued)****ESPM Application**

Separation of fuel quantity and level indicating system wiring from other wiring.

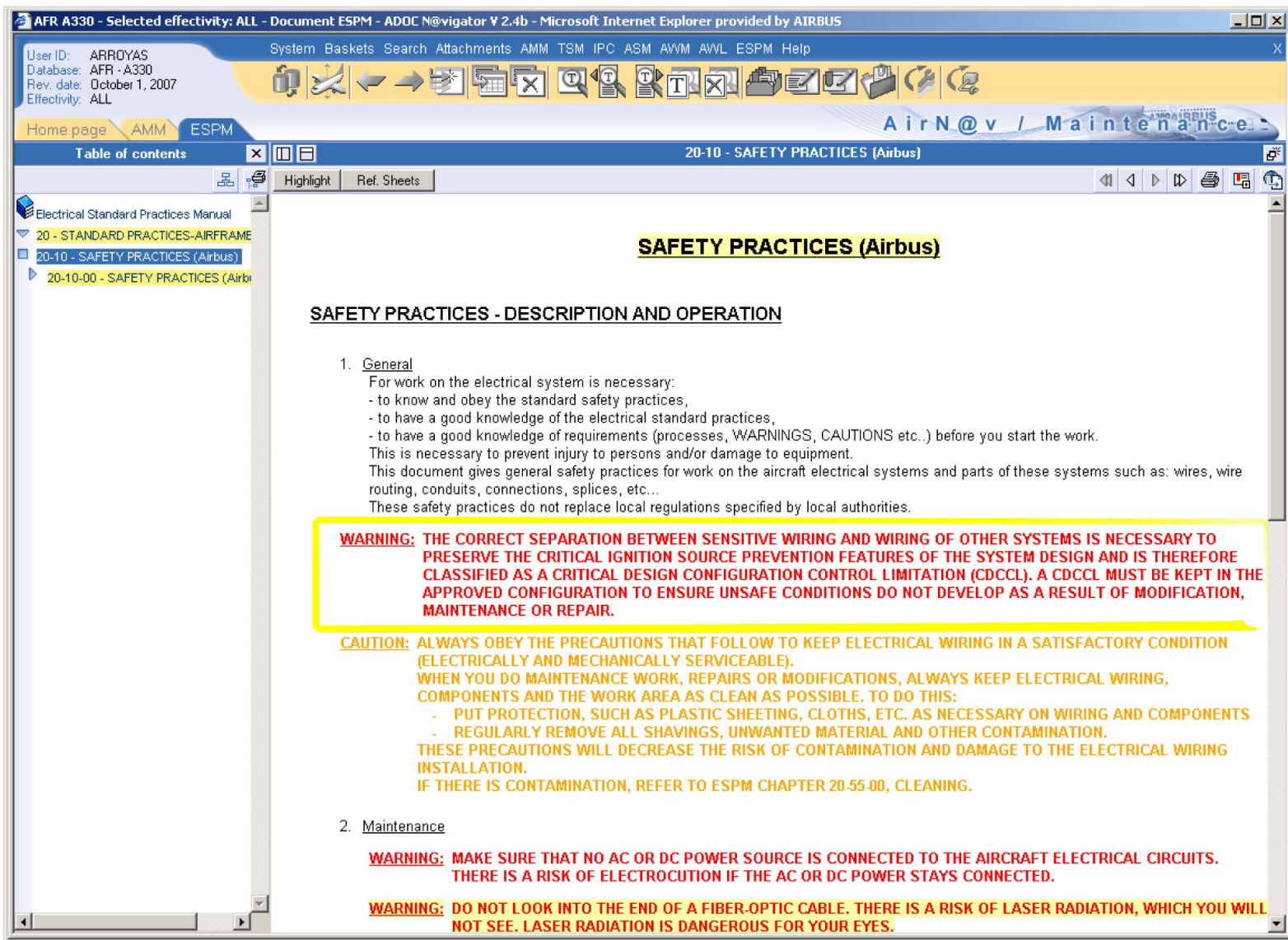

**SAFETY PRACTICES (Airbus)**

**SAFETY PRACTICES - DESCRIPTION AND OPERATION**

1. General  
 For work on the electrical system is necessary:  
 - to know and obey the standard safety practices,  
 - to have a good knowledge of the electrical standard practices,  
 - to have a good knowledge of requirements (processes, WARNINGS, CAUTIONS etc..) before you start the work.  
 This is necessary to prevent injury to persons and/or damage to equipment.  
 This document gives general safety practices for work on the aircraft electrical systems and parts of these systems such as: wires, wire routing, conduits, connections, splices, etc...  
 These safety practices do not replace local regulations specified by local authorities.

**WARNING: THE CORRECT SEPARATION BETWEEN SENSITIVE WIRING AND WIRING OF OTHER SYSTEMS IS NECESSARY TO PRESERVE THE CRITICAL IGNITION SOURCE PREVENTION FEATURES OF THE SYSTEM DESIGN AND IS THEREFORE CLASSIFIED AS A CRITICAL DESIGN CONFIGURATION CONTROL LIMITATION (CDCCL). A CDCCL MUST BE KEPT IN THE APPROVED CONFIGURATION TO ENSURE UNSAFE CONDITIONS DO NOT DEVELOP AS A RESULT OF MODIFICATION, MAINTENANCE OR REPAIR.**

**CAUTION: ALWAYS OBEY THE PRECAUTIONS THAT FOLLOW TO KEEP ELECTRICAL WIRING IN A SATISFACTORY CONDITION (ELECTRICALLY AND MECHANICALLY SERVICEABLE). WHEN YOU DO MAINTENANCE WORK, REPAIRS OR MODIFICATIONS, ALWAYS KEEP ELECTRICAL WIRING, COMPONENTS AND THE WORK AREA AS CLEAN AS POSSIBLE. TO DO THIS:**  
 - PUT PROTECTION, SUCH AS PLASTIC SHEETING, CLOTHS, ETC. AS NECESSARY ON WIRING AND COMPONENTS  
 - REGULARLY REMOVE ALL SHAVINGS, UNWANTED MATERIAL AND OTHER CONTAMINATION.  
 THESE PRECAUTIONS WILL DECREASE THE RISK OF CONTAMINATION AND DAMAGE TO THE ELECTRICAL WIRING INSTALLATION.  
 IF THERE IS CONTAMINATION, REFER TO ESPM CHAPTER 20-55-00, CLEANING.

2. Maintenance

**WARNING: MAKE SURE THAT NO AC OR DC POWER SOURCE IS CONNECTED TO THE AIRCRAFT ELECTRICAL CIRCUITS. THERE IS A RISK OF ELECTROCUTION IF THE AC OR DC POWER STAYS CONNECTED.**

**WARNING: DO NOT LOOK INTO THE END OF A FIBER-OPTIC CABLE. THERE IS A RISK OF LASER RADIATION, WHICH YOU WILL NOT SEE. LASER RADIATION IS DANGEROUS FOR YOUR EYES.**

MAINTENANCE APPLICATION OF CDCCL - ESPM APPLICATION

V1813401 - V01T0M0 - XM28D1000000001

**FUEL TANK SAFETY PROCEDURES (2)****Maintenance Application of CDCCL (continued)****AMM Application**

Direct bonding on items of an equipment inside a fuel tank.



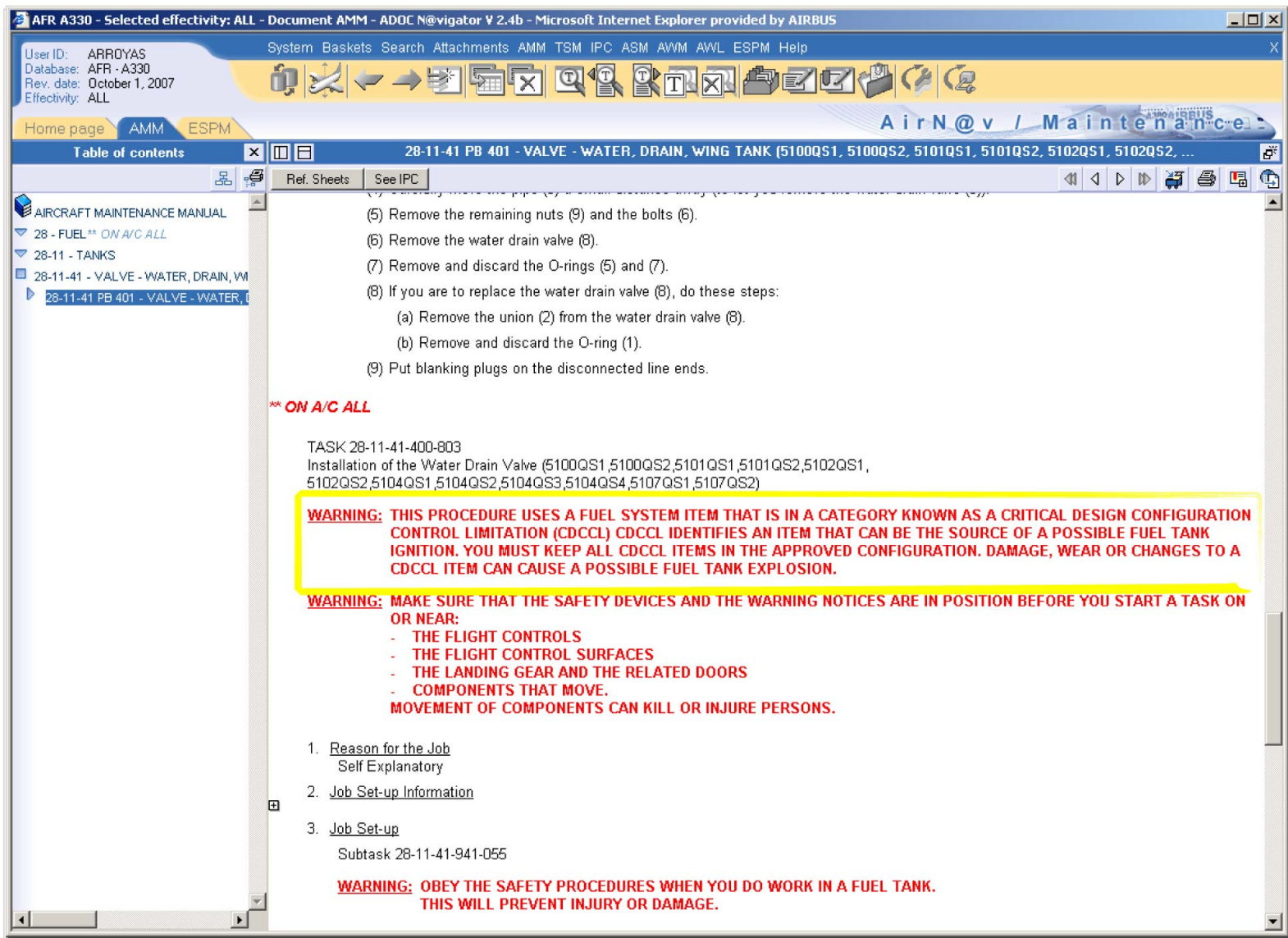

AFR A330 - Selected effectivity: ALL - Document AMM - ADOC N@vigator V 2.4b - Microsoft Internet Explorer provided by AIRBUS

User ID: ARROYAS  
 Database: AFR - A330  
 Rev. date: October 1, 2007  
 Effectivity: ALL

System Baskets Search Attachments AMM TSM IPC ASM AWM AWL ESPM Help

Home page AMM ESPM

Table of contents

AIRCRAFT MAINTENANCE MANUAL

- 28 - FUEL\*\* ON A/C ALL
- 28-11 - TANKS
- 28-11-41 - VALVE - WATER, DRAIN, WM
- 28-11-41 PB 401 - VALVE - WATER, DRAIN, WM

28-11-41 PB 401 - VALVE - WATER, DRAIN, WING TANK (5100QS1, 5100QS2, 5101QS1, 5101QS2, 5102QS1, 5102QS2, ...)

Ref. Sheets See IPC

(5) Remove the remaining nuts (9) and the bolts (6).  
 (6) Remove the water drain valve (8).  
 (7) Remove and discard the O-rings (5) and (7).  
 (8) If you are to replace the water drain valve (8), do these steps:  
 (a) Remove the union (2) from the water drain valve (8).  
 (b) Remove and discard the O-ring (1).  
 (9) Put blanking plugs on the disconnected line ends.

**\*\* ON A/C ALL**

TASK 28-11-41-400-803  
 Installation of the Water Drain Valve (5100QS1,5100QS2,5101QS1,5101QS2,5102QS1, 5102QS2,5104QS1,5104QS2,5104QS3,5104QS4,5107QS1,5107QS2)

**WARNING: THIS PROCEDURE USES A FUEL SYSTEM ITEM THAT IS IN A CATEGORY KNOWN AS A CRITICAL DESIGN CONFIGURATION CONTROL LIMITATION (CDCCL) CDCCL IDENTIFIES AN ITEM THAT CAN BE THE SOURCE OF A POSSIBLE FUEL TANK IGNITION. YOU MUST KEEP ALL CDCCL ITEMS IN THE APPROVED CONFIGURATION. DAMAGE, WEAR OR CHANGES TO A CDCCL ITEM CAN CAUSE A POSSIBLE FUEL TANK EXPLOSION.**

**WARNING: MAKE SURE THAT THE SAFETY DEVICES AND THE WARNING NOTICES ARE IN POSITION BEFORE YOU START A TASK ON OR NEAR:**

- THE FLIGHT CONTROLS
- THE FLIGHT CONTROL SURFACES
- THE LANDING GEAR AND THE RELATED DOORS
- COMPONENTS THAT MOVE.

**MOVEMENT OF COMPONENTS CAN KILL OR INJURE PERSONS.**

1. Reason for the Job  
 Self Explanatory

2. Job Set-up Information

3. Job Set-up  
 Subtask 28-11-41-941-055

**WARNING: OBEY THE SAFETY PROCEDURES WHEN YOU DO WORK IN A FUEL TANK. THIS WILL PREVENT INJURY OR DAMAGE.**

MAINTENANCE APPLICATION OF CDCCL - AMM APPLICATION

V1813401 - V01T0M0 - XM28D1000000001

---

**FUEL TANK SAFETY PROCEDURES (2)****Maintenance Application of CDCCL (continued)****CMM Application**

Safety critical features of fuel pumps: these features must be maintained throughout the full life of the fuel pump to avoid a possible ignition source by overheating or sparks caused by arcing, or friction etc...

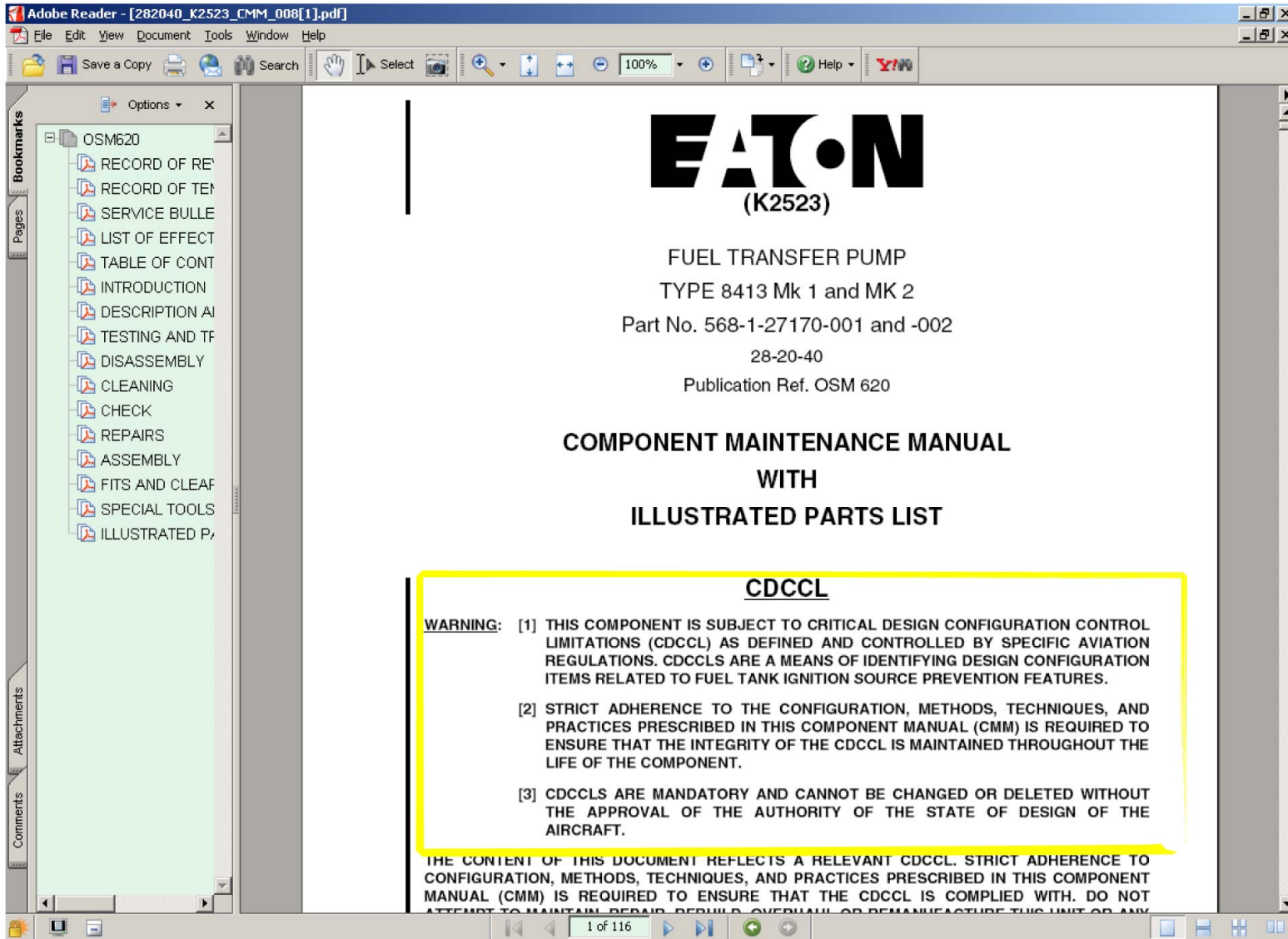

**EATON**  
(K2523)

FUEL TRANSFER PUMP  
TYPE 8413 Mk 1 and MK 2  
Part No. 568-1-27170-001 and -002  
28-20-40  
Publication Ref. OSM 620

**COMPONENT MAINTENANCE MANUAL  
WITH  
ILLUSTRATED PARTS LIST**

**CDCCL**

**WARNING:** [1] THIS COMPONENT IS SUBJECT TO CRITICAL DESIGN CONFIGURATION CONTROL LIMITATIONS (CDCCL) AS DEFINED AND CONTROLLED BY SPECIFIC AVIATION REGULATIONS. CDCCLS ARE A MEANS OF IDENTIFYING DESIGN CONFIGURATION ITEMS RELATED TO FUEL TANK IGNITION SOURCE PREVENTION FEATURES.

[2] STRICT ADHERENCE TO THE CONFIGURATION, METHODS, TECHNIQUES, AND PRACTICES PRESCRIBED IN THIS COMPONENT MANUAL (CMM) IS REQUIRED TO ENSURE THAT THE INTEGRITY OF THE CDCCL IS MAINTAINED THROUGHOUT THE LIFE OF THE COMPONENT.

[3] CDCCLS ARE MANDATORY AND CANNOT BE CHANGED OR DELETED WITHOUT THE APPROVAL OF THE AUTHORITY OF THE STATE OF DESIGN OF THE AIRCRAFT.

THE CONTENT OF THIS DOCUMENT REFLECTS A RELEVANT CDCCL. STRICT ADHERENCE TO CONFIGURATION, METHODS, TECHNIQUES, AND PRACTICES PRESCRIBED IN THIS COMPONENT MANUAL (CMM) IS REQUIRED TO ENSURE THAT THE CDCCL IS COMPLIED WITH. DO NOT ATTEMPT TO MAINTAIN, REPAIR, REBUILD, OVERHAUL OR REMANUFACTURE THIS UNIT OR ANY

MAINTENANCE APPLICATION OF CDCCL - CMM APPLICATION

V1813401 - V01T0M0 - XM28D1000000001

**FUEL TANK SAFETY PROCEDURES (2)****Maintenance Application of CDCCL (continued)****MPD Application**

Application in Maintenance Planning Document.

**A380**

MAINTENANCE PLANNING DOCUMENT

TASK NUMBER	ZONE	DESCRIPTION	THRESHOLD INTERVAL	SOURCE	REFERENCE	MEN	M/H	APPLICABILITY
281400-00003-01	198	PIPE SHROUD DRAINAGE AF OPC CHECK DRAIN MAST/LEAK MONITOR FOR BLOCKAGE/OPERATION.	I: 12 MO	MRB 9	281400-210-801 MRB REFERENCE 281400-00003-01M	1	0.10	A380-800
281400-00004-01	140 310	PIPE SHROUD DRAINAGE AF FNC PRESSURE CHECK TRIM TRANSFER PIPE SHROUD FOR INTEGRITY. ACCESS: 143AZ 197BB 198BB 311AB	I: 48 MO	MRB 8	281400-780-803 MRB REFERENCE 281400-00004-01M	1 1	0.60 0.60	A380-800
281400-00005-01	140 310	PIPE SHROUD DRAINAGE AF FNC PRESSURE CHECK APU FUEL FEED PIPE SHROUD FOR INTEGRITY. ACCESS: 143AZ 197BB 198BB 313AB	I: 48 MO	MRB 8	281400-780-804 MRB REFERENCE 281400-00005-01M	1 1	0.60 0.60	A380-800
281400-00006-01	198	PIPE SHROUD DRAINAGE AF OPC CHECK LEAK MONITOR FOR CORRECT OPERATION.	I: 7 DY	MRB 9	281400-710-802 MRB REFERENCE 281400-00006-01M	1	0.05	A380-800
281800-00001-01	140 300 500 600	IGNITION PREVENTION AF DET DETAILED INSPECTION OF WING AND TRIM TANK BONDING LEADS. ACCESS: 311AB	I: 144 MO	MRB 9	281800-220-801 MRB REFERENCE 281800-00001-01M	1 1 1 1	2.20 2.20 2.20 2.20	A380-800
281800-00002-01	500 600	IGNITION PREVENTION AF GVI GENERAL VISUAL INSPECTION OF COMPOSITE RIB BONDING STRAPS. ACCESS: 541AB 542DB 542EB 543AB 543BB 543CB 543DB 543EB 544AB 544BB 544CB 544DB ***** CONTINUED *****	I: 144 MO	MRB 9	281800-210-803 MRB REFERENCE 281800-00002-01M	1 1	0.90 0.90	A380-800

SYSTEMS AND POWER PLANT PROGRAM : FUEL

ISSUE: JUN 01/07

SECTION: 2-28

PAGE 3

MAINTENANCE APPLICATION OF CDCCL - MPD APPLICATION

V1813401 - V01T0M0 - XM28D1000000001

**FUEL TANK SAFETY PROCEDURES (2)****Maintenance Application of CDCCL (continued)****SB Application**

Service bulletin applicable on single aisle family aircraft.

**A318/A319/A320/A321**

 SERVICE BULLETIN  
 REVISION TRANSMITTAL SHEET

 AIRBUS  
 CUSTOMER SERVICES DIRECTORATE  
 1 Rond Point Maurice Bellonte  
 31707 BLAGNAC CEDEX FRANCE  
 Tel : (33) 5 61 93 33 33  
 Telex : AIRBU 530526F  
 Fax : (33) 5 61 93 42 51

ATA SYSTEM : 33

 TITLE : LIGHTS - CARGO AND SERVICE COMPARTMENTS - INSTALL MAINTENANCE LIGHT  
 F1000955-01

MODIFICATION No. : 33593K9935

This page transmits Revision No. 01 of Service Bulletin No. A320-33-1044.

**ADDITIONAL WORK**

No additional work is required by this revision for aircraft modified by any previous issue.

**REASON**

This Revision is issued to :

- update the operators,
- update the Weight and Balance Information of Kit D01 and D02.

**CHANGES**

SUMMARY :

- REASON/DESCRIPTION/OPERATIONAL CONSEQUENCES
  - . Kit price changed from 1470 to 1560 USD.

## - EFFECTIVITY

- . Operators updated.

PLANNING INFORMATION :

## - EFFECTIVITY

- . 1.A. Operators updated.

## - WEIGHT AND BALANCE

- . 1.H. Weight and Balance updated.

## - REFERENCES

- . 1.J. AMM reference 33-37-00 added.

6 DATE : Mar 25/05

SERVICE BULLETIN No. : A320-33-1044

REVISION No. : 01 - Aug 22/05

Page : 1 of 2

Printed in FRANCE © AIRBUS, 2005 All rights reserved

**A318/A319/A320/A321**

 SERVICE BULLETIN  
 SUMMARY

 AIRBUS  
 CUSTOMER SERVICES DIRECTORATE  
 1 Rond Point Maurice Bellonte  
 31707 BLAGNAC CEDEX FRANCE  
 Tel : (33) 5 61 93 33 33  
 Telex : AIRBU 530526F  
 Fax : (33) 5 61 93 42 51

 This summary is for information only  
 and is not approved for modification of the aircraft

ATA SYSTEM : 33

 TITLE : LIGHTS - CARGO AND SERVICE COMPARTMENTS - INSTALL MAINTENANCE LIGHT  
 F1000955-01

MODIFICATION No. : 33593K9935

**REASON/DESCRIPTION/OPERATIONAL CONSEQUENCES**

The Special Federal Aviation Regulation (SFAR) 88 requests that the hydraulic area is protected against fuel vapour ignition. In order to fulfill the SFAR 88 requirements the maintenance lights 9LL and 10LL have been removed with Service Bulletin No. A320-92-1032.

This Service Bulletin details the procedure to replace maintenance lights 9LL and 10LL, PN 2LA002606-01, previously removed, with maintenance lights, PN F1000955-01.

The accomplishment of this Service Bulletin will fulfil the requirements of the SFAR 88 in maintenance areas.

EVALUATION TABLE

COMPLIANCE	Recommended	CANCELS INSPECTION SB	No
POTENTIAL AD	No	A/C OPERATION AFFECTED	No
RELIABILITY AFFECTED	No	PAX COMFORT AFFECTED	No
COST SAVING	No	ETOPS AFFECTED	No
STRUCTURAL LIFE EXTN	No	VENDOR SB INVOLVED	No
KIT PRICE (USD)D01	1560	KIT PRICE (USD)D02	1560

**EFFECTIVITY**

This Service Bulletin is applicable to this (these) operator(s) :

 30X 31X 53Z 57Y 72Y 83Y 88Y A1L AAF AAR ABQ ABY ACA ACC ADR AFL AFR AHY AJM ALK  
 AMC AMU ANA ANZ ARF AUA AWE AZA BAW BES BGH BIE BMA BWG CBF CCM CES CIB CJG CNW  
 CRX CSA CSC CSN CTN CXN CYP D2F DAT DCS DGA DKN DLH EDW EEZ EGN EIN EIR EZY F2I  
 F2L FCA FFT FHY FIN G2X G4I G8E GBL GFA GWI GWY HDA HEJ HVN I2L IAC IBE IRM ISS  
 IWD JBU JCS JET JKK JST KAC KYV LAJ LAN LAO LBT LTC LTE LTU LVG LXR MAU MEA MHS

6 DATE : Mar 25/05

SERVICE BULLETIN No. : A320-33-1044

REVISION No. : 01 - Aug 22/05

Page : 1 of 4

**MAINTENANCE APPLICATION OF CDCCL - SB APPLICATION**

**FUEL TANK SAFETY PROCEDURES (2)****Maintenance Application of CDCCL (continued)****AD Application**

Extract of the Airworthiness Directive.





**FAA**  
Aircraft Certification Service

**AIRWORTHINESS DIRECTIVE**

[www.faa.gov/aircraft/safety/alerts/](http://www.faa.gov/aircraft/safety/alerts/)  
[www.gpoaccess.gov/fr/advanced.html](http://www.gpoaccess.gov/fr/advanced.html)

**2007-15-06 Airbus:** Amendment 39-15135. Docket No. FAA-2007-27268; Directorate Identifier 2006-NM-190-AD.

**Effective Date**

(a) This AD becomes effective August 28, 2007.

**Affected ADs**

(b) None.

...

**Revise ALS To Incorporate CDCCLs**

(g) Within 12 months after the effective date of this AD, revise the ALS of the Instructions for Continued Airworthiness to incorporate Airbus A318/A319/A320/A321 ALS Part 5–Fuel Airworthiness Limitations, dated February 28, 2006, as defined in Airbus A318/A319/A320/A321 Fuel Airworthiness Limitations, Document 95A.1931/05, Issue 1, dated December 19, 2005 (approved by the EASA on March 14, 2006), Section 2, "Critical Design Configuration Control Limitations."

**No Alternative Inspections, Inspection Intervals, or CDCCLs**

(h) Except as provided by paragraph (i) of this AD: After accomplishing the actions specified in paragraphs (f) and (g) of this AD, no alternative inspections, inspection intervals, or CDCCLs may be used.

...

**MAINTENANCE APPLICATION OF CDCCL - AD APPLICATION**

V1813401 - V01T0M0 - XM28D1000000001

---

## FUEL TANK SAFETY PROCEDURES (2)

### **Safety Precautions**

Make sure that you have the correct fire fighting equipment available. When you have to work on a fuel system wiring, you must use test equipment that is approved (otherwise, unapproved equipment could cause fire or an explosion).

Make sure that the lighting in the work area is sufficient to work safely. Wear protective goggles or face mask, clothes and gloves and avoid wearing metallic clothing (e.g. footwear or a belt with a metal buckle) which can cause sparks.

In the work area you must not:

- smoke,
- use flames which do not have protection,
- operate electrical equipment which is not necessary for the task,
- pull or move metal objects along the ground,
- use hearing-aids or battery-operated equipment which will cause sparks.



**Ignition**



**Oxygen**

**Fuel**



**SAFETY PRECAUTIONS**

V1813401 - V01T0M0 - XM28D1000000001

## FUEL TANK SAFETY PROCEDURES (2)

### **Safety Areas And Accessibility**

Put the safety barriers in position and put the warning notices, to tell persons not to operate the fuel system, not to refuel the aircraft and not to operate the flaps.

Defuel the applicable wing tank or do a ground fuel transfer. Use the ECAM to make sure that the applicable fuel tank valves are closed and drain the remaining fuel

Open and safety tag circuit breakers for refuel system, refuel panel, applicable fuel valves and SFCC (Slat Flap Control Computers).

Open the related fuel tanks access panels.

**NOTE:** Note: Some of these precautions are the minimum safety standard for work in a fuel tank. Local regulations can make other safety precautions necessary.

Safety barriers & warning notices must be in position prior to starting a task.

Do not operate the fuel system or the F/CTL (Slats & Flaps) or the L/G system : Movement of surrounding components can kill or injure people.

Defuel and drain the applicable wing tank.

Then open the fuel tank access panels :

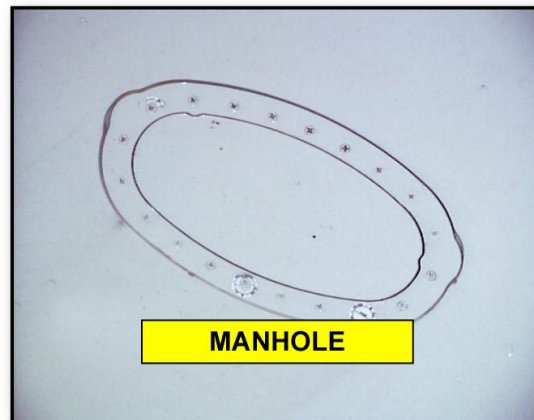

**EXAMPLE OF AN UNDER-WING FUEL TANK ACCESS PANEL (MANHOLE)**

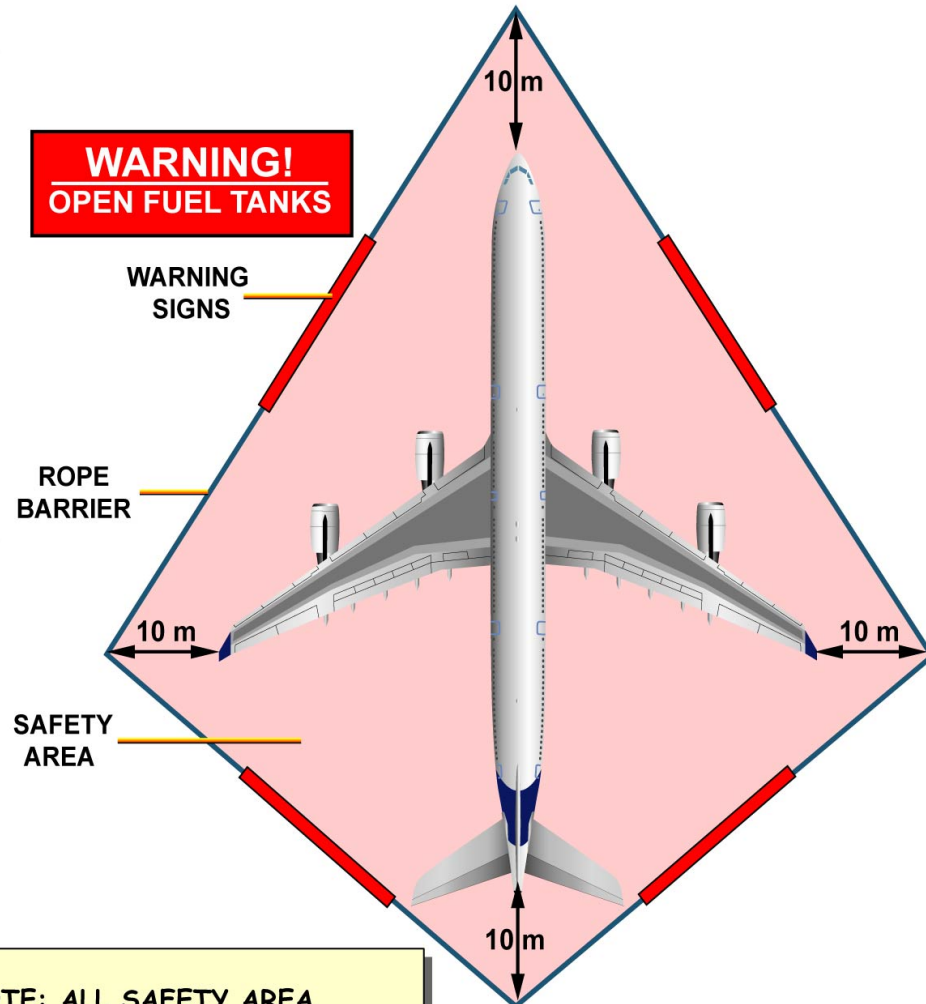

**NOTE: ALL SAFETY AREA CLEARANCES ARE SUBJECT TO CHANGE ACCORDING TO LOCAL AIRPORT REGULATIONS.**

**SAFETY AREAS AND ACCESSIBILITY**

V1813401 - V01T0M0 - XM28D1000000001

---

## FUEL TANK SAFETY PROCEDURES (2)

### **Tanks Ventilation**

Vent the tanks with a proper venting system (fitted with minimum 1 air inlet & 1 air outlet).

Check with a combustible gas indicator (after minimum 6 hours of ventilation) the tanks fuel gas concentration.

The fuel gas concentration must be < 10% of the Lower Explosive Limit (LEL) before entering into the tanks.

**WARNING:** You must use a respirator if the fuel-gas concentration in the fuel tanks is more than 5% of the Lower Explosive Limit (LEL).

**VENTING SYSTEM**

**Vent the tanks with a proper venting system  
(fitted with minimum 1 air inlet & 1 air outlet)**



**WARNING**

**KEEP THE VENTILATION  
AVAILABLE DURING THE  
COMPLETE WORK PROGRESS  
IN THE TANKS.**

**Check with a combustible gas indicator (after  
minimum 6 hours of ventilation) the tanks fuel  
gas concentration.**

**Fuel gas concentration must be < 10% of the  
Lower Explosive Limit (LEL) before entering into  
the tanks.**

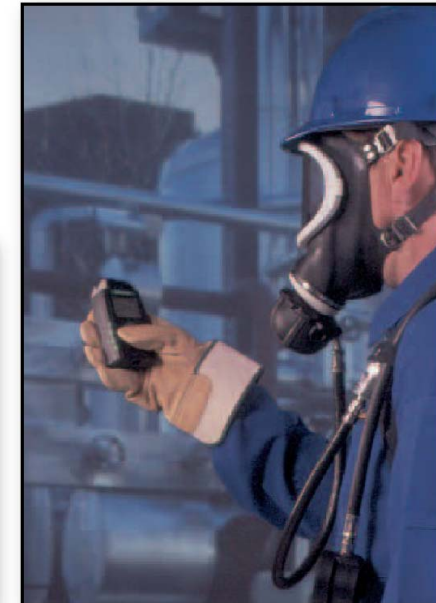
**COMBUSTIBLE  
GAS INDICATOR**

**TANKS VENTILATION**

---

## FUEL TANK SAFETY PROCEDURES (2)

### Entry Check-List

You must complete the Pre-Entry Checklist before you do work in a fuel tank.

Finally, get access to the applicable work area.

#### WARNING: S:

- do not touch or push against the magnetic level indicators when you are in the fuel tank. This will prevent damage to them.
- do not touch or push against the FQI probes when you are in the fuel tank. This will prevent damage to them and their installation.
- do not cause damage to the internal structure, sealant, electrical cables, or conduits during maintenance.



Following the AMM Fuel Safety Procedures, maintenance personnel must fill in this **PRE-ENTRY CHECK LIST** before entering and working in the fuel tank.



**EXTRACT OF AN A330 AMM  
FUEL TANK ENTRY CHECKLIST**

**ENTRY CHECK-LIST**

This check list must be complete before you do work in the fuel tank.

**Wet Fuel Tank Entry Location**

Aircraft: \_\_\_\_\_ Tank: \_\_\_\_\_ Shift: \_\_\_\_\_ Date: \_\_\_\_\_

Shift Supervisor is: \_\_\_\_\_

the box when you have made sure that :-

1. All the aircraft electrical circuits are de-energized.
2. The aircraft is electrically grounded.
3. All the access platforms and associated equipment are electrically grounded.
4. All the electrical ground power units are disconnected.
5. Access to the area is limited and warning signs are in position.
6. A checklist of all tools and equipment to be used in the fuel tank is available.
7. Only approved spark-proof lamps and torches are in the work area. Sealed vapor-lamps are not to be used.
8. Only approved protective clothing is used.
9. The tank entry person and the safety person each have two air-supplied respirators that operate satisfactorily.
10. Both the tank entry person and the safety person have current medical certificates for entry into tanks.
11. Lint free cloths and special fire-proof containers are available to remove all remaining fuel.
12. There is a continuous flow of clean filtered air through the fuel tank available when the person is in the tank.
13. The vapor concentration is less than 25% of the applicable Lower Explosion Limit (LEL).
14. Correct fire fighting equipment and approved persons available.
15. The fire department has been told.

**Meter Reading**

16. Fuel-Gas concentration (LEL) reading prior to tank entry is: \_\_\_\_\_

I confirm that all entry requirements were met before entry was made into the tanks.

Signature of Supervisor \_\_\_\_\_ Date/Time \_\_\_\_\_

Pre-Entry Checklist into a Wet Fuel Tank

V1813401 - V01T0M0 - XM28D1000000001

## FUEL TANK SAFETY PROCEDURES (2)

### Working Environment

**NOTE:** Note: You may have to remove parts of the structure (and equipment) to get access to parts of the tank.

Use protective mats on the floor of the fuel tank to prevent:

- damage to the fuel tank structure,
- injury to persons,
- safety all components before you place them inside the fuel tank,
- all wire locking must be installed/adjusted outside the fuel tank.

Use only RED tie wraps in the fuel tanks.

Use only approved cleaning materials.

Make sure that all signs of solvents and cleaning agents are removed from the equipment/components before they are installed.

Put blanking caps on all disconnected pipes and openings in components and tanks.

Do not connect electrical equipment to a power source less than 30 meters away, unless the power source has spark-proof connectors.

You must obey the fuel safety procedures when you do work in a fuel tank. When differences occur, you must use the approved precautions of this procedure.

**WARNING:** Do not use metallic wire wool in fuel tanks.



Maintenance personnel working in fuel tanks must :

- work in team (safety person required)
- use proper lighting(e.g. spark proof lamp)
- use proper filtered air supply
- use protective mats on the floor to prevent damage to people and structure
- make sure that all the fuel system components have correct electrical bonding.
- record the removed parts and record the position of each panel bolt. This will prevent damage to the structure.

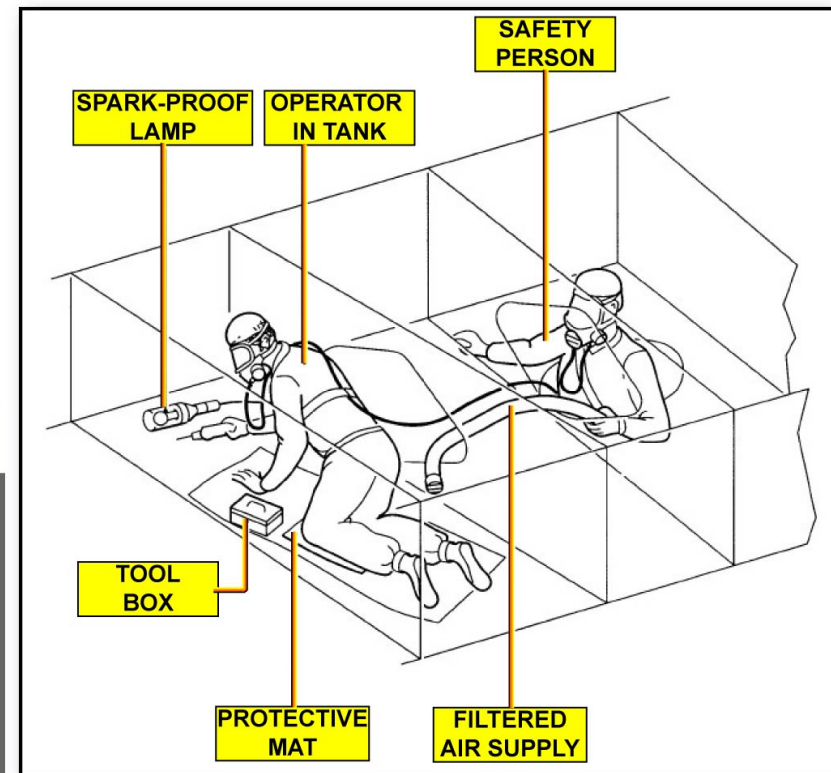
**WORKING ENVIRONMENT**

---

## FUEL TANK SAFETY PROCEDURES (2)

### Close-Up

After completion of a work in a fuel tank, personnel must make sure that:

- the work area is clear of tools,
- the work area is clean,
- no electrical equipment has been damaged and disconnected,
- all the fuel system components have a correct electrical bonding,
- all access panels are back in their original position (e.g. rib access panels).

After completion of a work in a fuel tank, personnel must make sure that :

- the work area is clear of tools
- the work area is clean
- no electrical equipment has been damaged and disconnected
- all the fuel system components have a correct electrical bonding.
- all access panels are back in their original position (e.g. rib access panels)

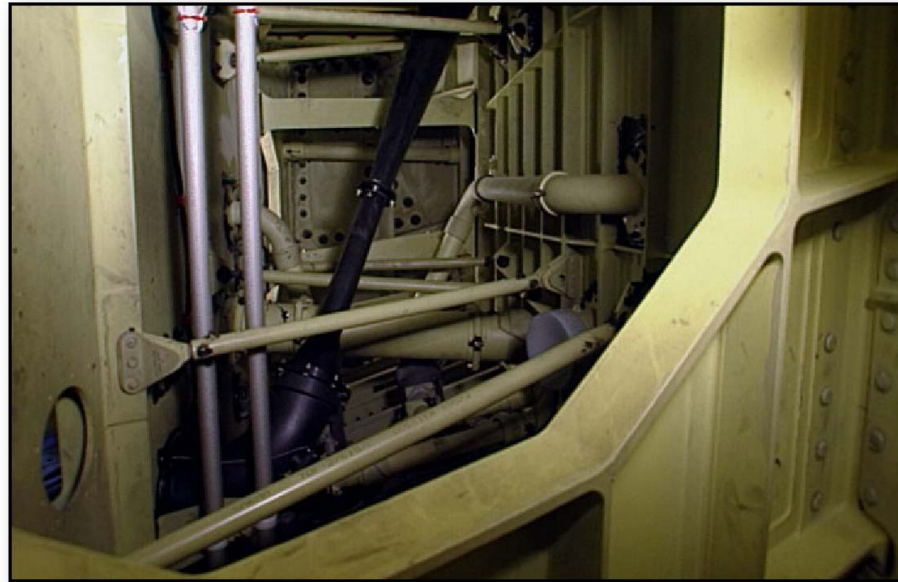

**EXAMPLE OF AN AIRBUS A330/A340 WING FUEL TANK (COLLECTOR CELL)**

CLOSE-UP

## TANKS AND WATER DRAINAGE SYSTEM DESCRIPTION (2/3)

### Function/Description of the Tanks

Tanks are divided into two different categories: fuel tanks and vent/surge tanks. The fuel tanks are used for fuel storage to supply the engines and the APU. Three tanks are used for fuel storage:

- The left wing fuel tank
- The center fuel tank
- The right wing fuel tank.

The structural geometry of the fuel tanks is designed to keep fuel loss to a minimum, if structural damage occurs after an Uncontained Engine Rotor Failure (UERF) event. Two wing vent/surge tanks, one at each wing outboard end, collect fuel during some aircraft maneuvers or if there is an overflow during refueling. Some access panels give access to the fuel system elements.

### Fuel Tanks

The center tank has three cells:

- The left cell (inner part of left wing)
- The mid cell (center wing box)
- The right cell (inner part of right wing).

The fuel in the wing fuel tanks is the last fuel to be used. It thus gives relief for the wing bending moment which optimizes the structural weight of the aircraft. Each wing fuel tank has two parts: the wing fuel-tank collector-box and the wing fuel-tank main-cell. The function of the collector box is to keep fuel near the engine feed pumps during aircraft maneuvers. Fuel from the outboard part of the wing fuel tank flows into the collector box by gravity, through the check valves. Fuel is kept around the pump inlets during aircraft maneuvers because the check valves prevent movement of the fuel out of the collector box.

### Wing Vent/Surge Tanks

The design of the wing surge tanks makes sure that fuel released during aircraft maneuvers does not go overboard. A drain path, through

the non-return valves of the surge tank, is supplied between the wing vent/surge tank and the wing fuel tank. These valves let the fuel drain inboard from the wing vent/surge tank into the wing fuel-tank main-cell, but do not let it flow outboard.

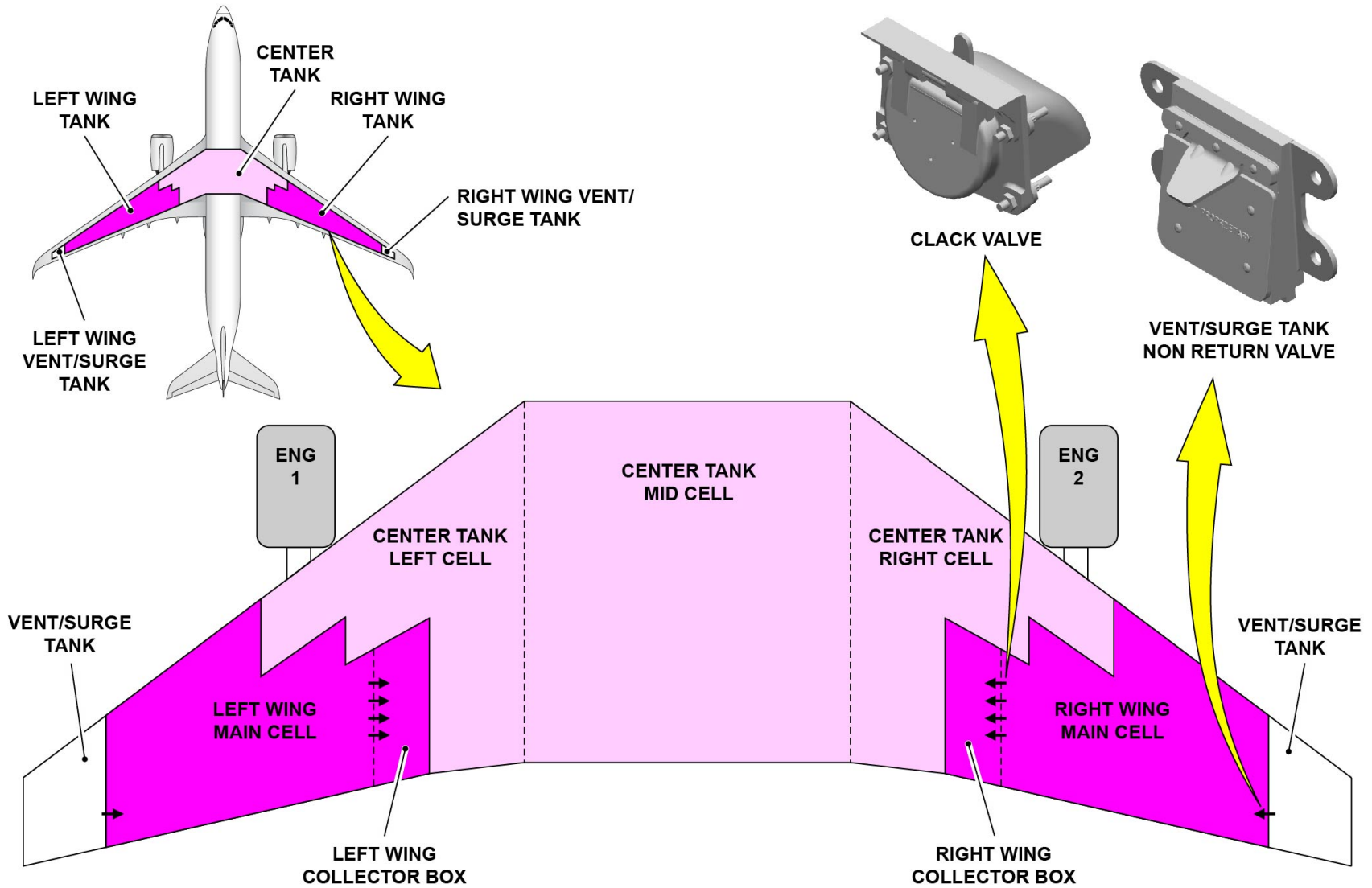

FUNCTION/DESCRIPTION OF THE TANKS - FUEL TANKS & WING VENT/SURGE TANKS

V1813401 - V01T0M0 - VM28DITANKS3001

---

**TANKS AND WATER DRAINAGE SYSTEM DESCRIPTION (2/3)****Function/Description of the Tanks (continued)****Tank Access Panels**

All the tanks have manhole access panels.



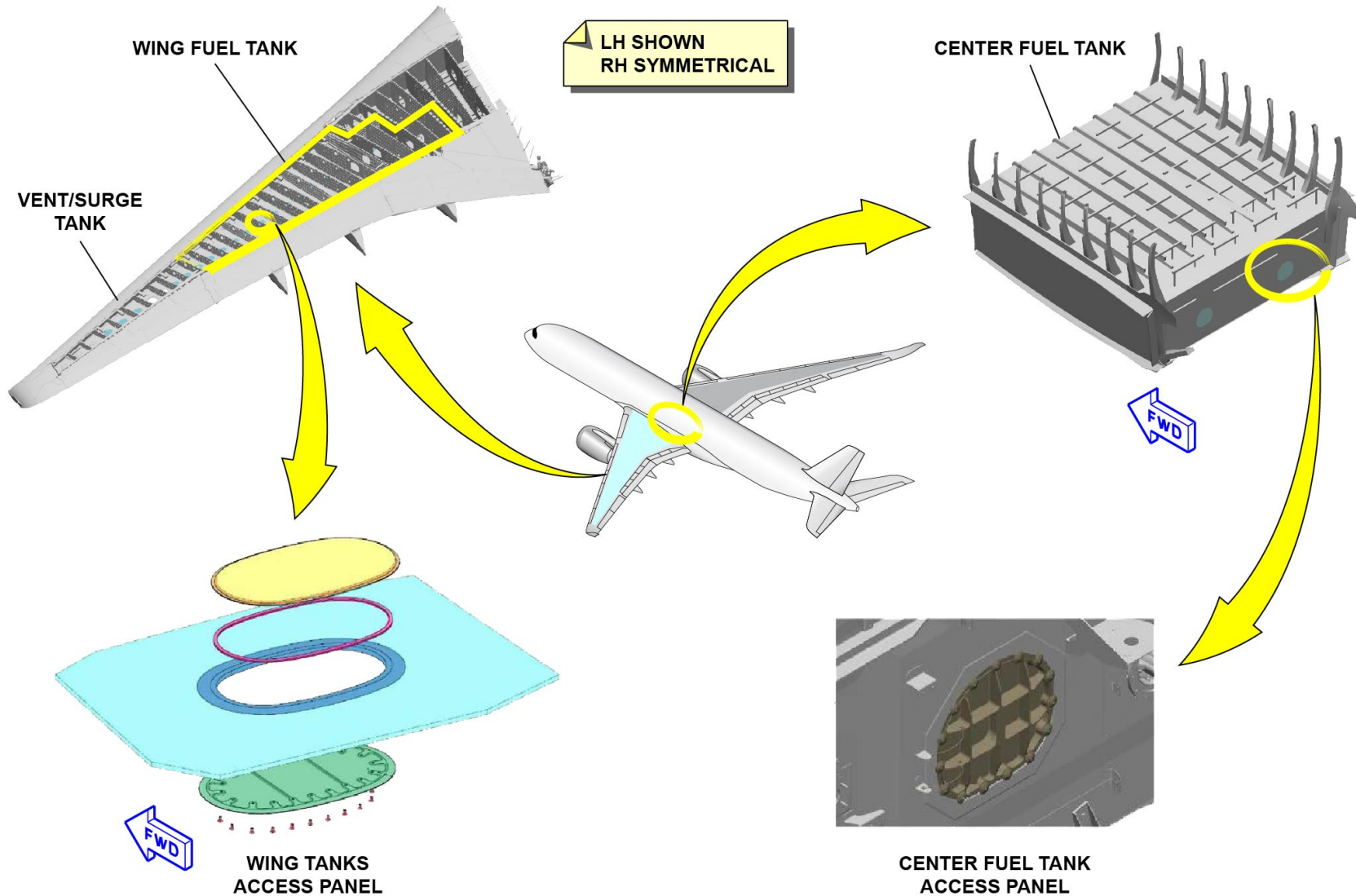

**FUNCTION/DESCRIPTION OF THE TANKS - TANK ACCESS PANELS**

V1813401 - V01T0M0 - VM28DITANKS3001

## TANKS AND WATER DRAINAGE SYSTEM DESCRIPTION (2/3)

### **Water Drainage Function/Description**

Large quantities of water are caused by the condensation effect of air contained in the fuel tanks. Water will also always be found in small quantities in the fuel uploaded. Collected water can cause the fuel quantity probe to give incorrect readings and can cause a contamination of the fuel supplied to the engines. There is also an increased risk of engine flow restriction because of ice formation. Microbiological contamination is also a risk where the aircraft operates in a hot and humid climate. Water drainage must be done at periodic intervals as per maintenance schedule. Each tank has one or more water drain valves. There are three types of water drain valves:

- Direct-water drain-valves
- Remote direct-water drain-valves
- Indirect water drain-valves.

#### **Direct Water Drain Valve**

Collected water is drained from the vent/surge tanks with direct water-drain valves. Direct water-drain valves are manually operated with a standard gravity tool.

#### **Remote Direct Water Drain Valve**

Water is removed from the center fuel tank with remote direct water-drain valves, operated through a remote inlet. Because they are fitted with extension tubes, the center tank water-drain valves are manually operated with a standard gravity tool from the access panels (belly fairing access).

#### **Indirect Water Drain Valve**

Indirect water-drain valves remove the water from the wing fuel-tank collector-box. Indirect water-drain valves are connected to the lowest point of the tank through a pipe and are manually operated.

For the indirect water-drain valves, if there is a low fuel quantity in the tank, it is recommended to drain the water with a suction procedure and not a gravity procedure.

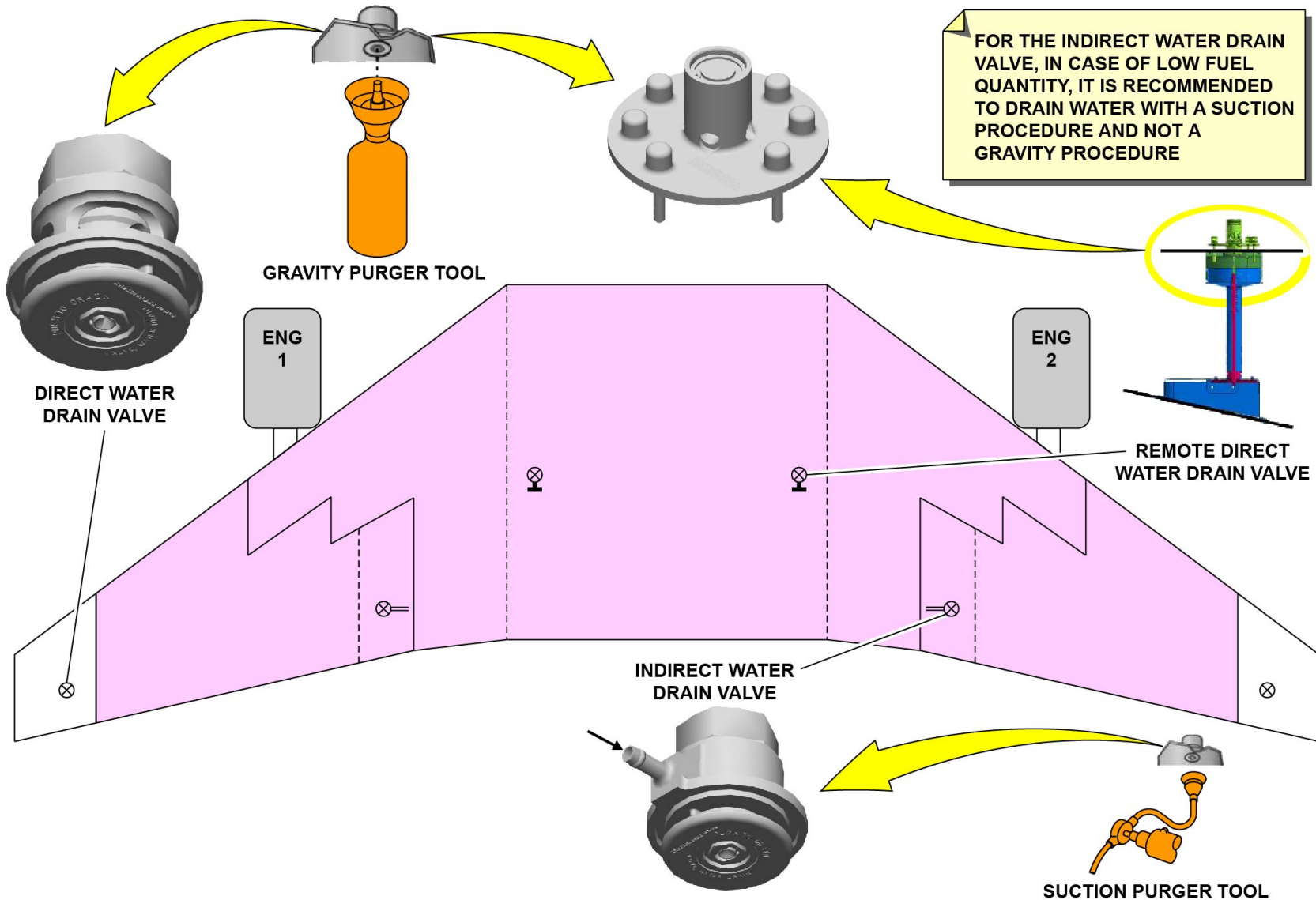

**WATER DRAINAGE FUNCTION/DESCRIPTION - DIRECT WATER DRAIN VALVE ... INDIRECT WATER DRAIN VALVE**

V1813401 - V01T0M0 - VM28DITANKS3001

## FUEL TANK VENTING SYSTEM DESCRIPTION (2/3)

### Venting System Function/Description

The function of the tank venting system is to keep the air pressure in the fuel tanks at approximately the external air pressure. This function prevents a large difference between these pressures which could cause damage to the fuel tank/aircraft structure. This is done by the free passage of air into and out of the tanks during all usual aircraft operating conditions.

The vent system of the tanks is necessary during the following operations:

- Refuel/Defuel/Transfers
- Climb/Descent.

### Components Description

The fuel tanks are connected to the vent/surge tanks by vent pipes. Each vent/surge tank is connected to the atmosphere through a NACA intake with a flame arrestor. Because of the NACA intake, the tanks can be lightly pressurized in flight. The NACA includes a flame arrestor that avoids the propagation of a flame from an external fire into the vent system and prevents ice formation. Overpressure protectors give an alternative path to release excessive pressure if the flame arrestor/NACA intake is blocked. There is one overpressure protector installed at the bottom of each vent/surge tank. The protection is given by a frangible disk with a white cross. When the disk is intact, the white cross is visible from outside the aircraft. Float vent valves are float-operated valves. These float vent valves supply ventilation for the wing fuel tanks for all applicable aircraft attitudes and fuel levels.

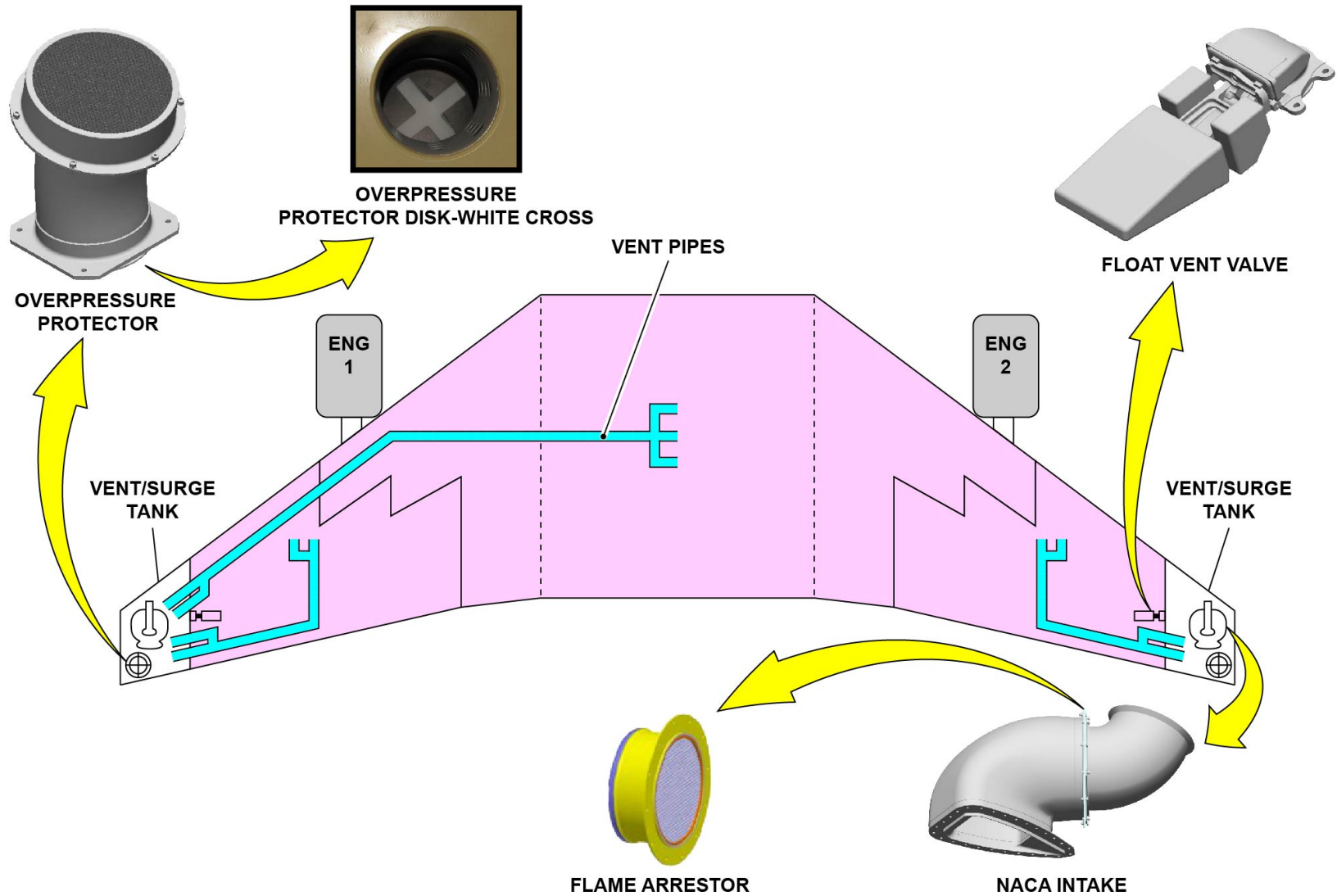

**VENTING SYSTEM FUNCTION/DESCRIPTION & COMPONENTS DESCRIPTION**

V1813401 - V01T0M0 - VM28D2FLVYG3001

## FUEL QUANTITY MANAGEMENT SYSTEM DESCRIPTION (2/3)

### **FQMS General Presentation**

The Fuel Quantity Management System (FQMS) supplies the aircraft with three primary functions:

- Measurement (this includes fuel quantities, temperatures, levels, wing imbalance and aircraft center of gravity) and transmission of the measured values to the CDS
- Management with pumps and valves commands and data from the Integrated Control Panel (ICP) (this includes the control of refueling, defueling, fuels transfers and jettison)
- Monitoring (this includes fuel system valves and pumps, and BITE tests).

The FQMS has:

- In-tank equipment
- Tank Wall Data Concentrators (3) (TWDCs), to process signals from the in-tank equipment
- An Integrated Refuel Panel (IRP)
- Some FQMS software in (4) CPIOMs.

The CPIOMs are divided into two sides: side 1 and side 2. Each side can support all the functional requirements of the fuel system. Only one side is active, the other one is on standby. Each side has the same interfaces with the fuel system and the other aircraft systems.

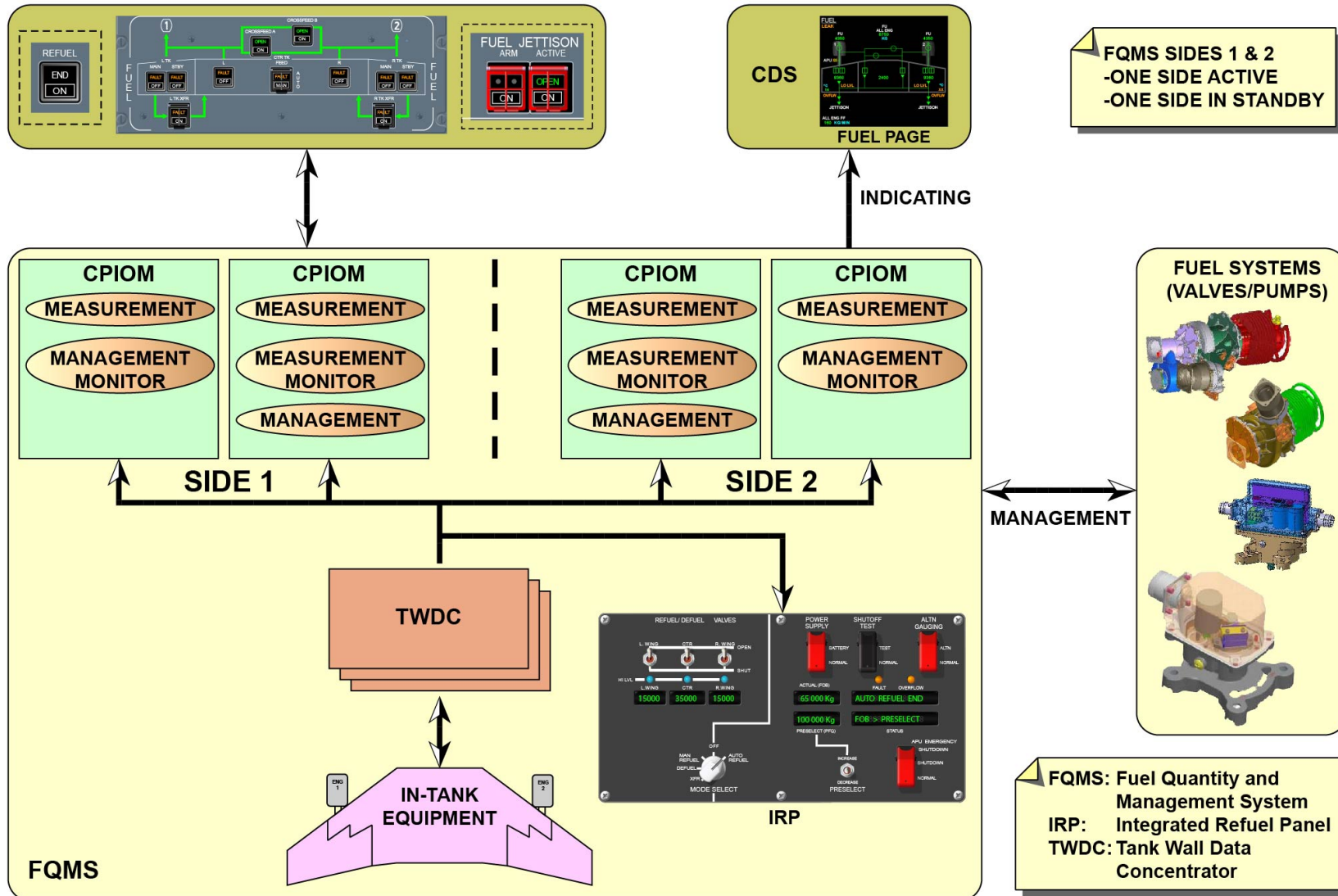

FQMS GENERAL PRESENTATION

V1813401 - V01T0M0 - VM28D3FQMS03001

---

## FUEL QUANTITY MANAGEMENT SYSTEM DESCRIPTION (2/3)

### **FQMS Description/Interfaces**

The FQMS has an interface with many aircraft systems, which includes:

- The Air Data/Inertial Reference System (ADIRS) for aircraft attitude data to calculate fuel tank volumes
- The Flight Management System (FMS) to process the BLOCK fuel request from the cockpit
- The APU Electronic Control Box (ECB) and the Propulsion Control System (PCS) to receive fuel used data for fuel leakage detection.

The TWDCs are reset through the two FQMS reset push-buttons. The FQMS 1 reset push-button also resets the CPIOMs side 1 and the FQMS 2 reset push-button resets side 2. Data of critical levels (such as low levels) are sent, at the same time, by the TWDCs:

- To the CPIOMs by Controller Area Network (CAN)
- To the CRDCs by discretes. The CRDCs then change the data into digital format.



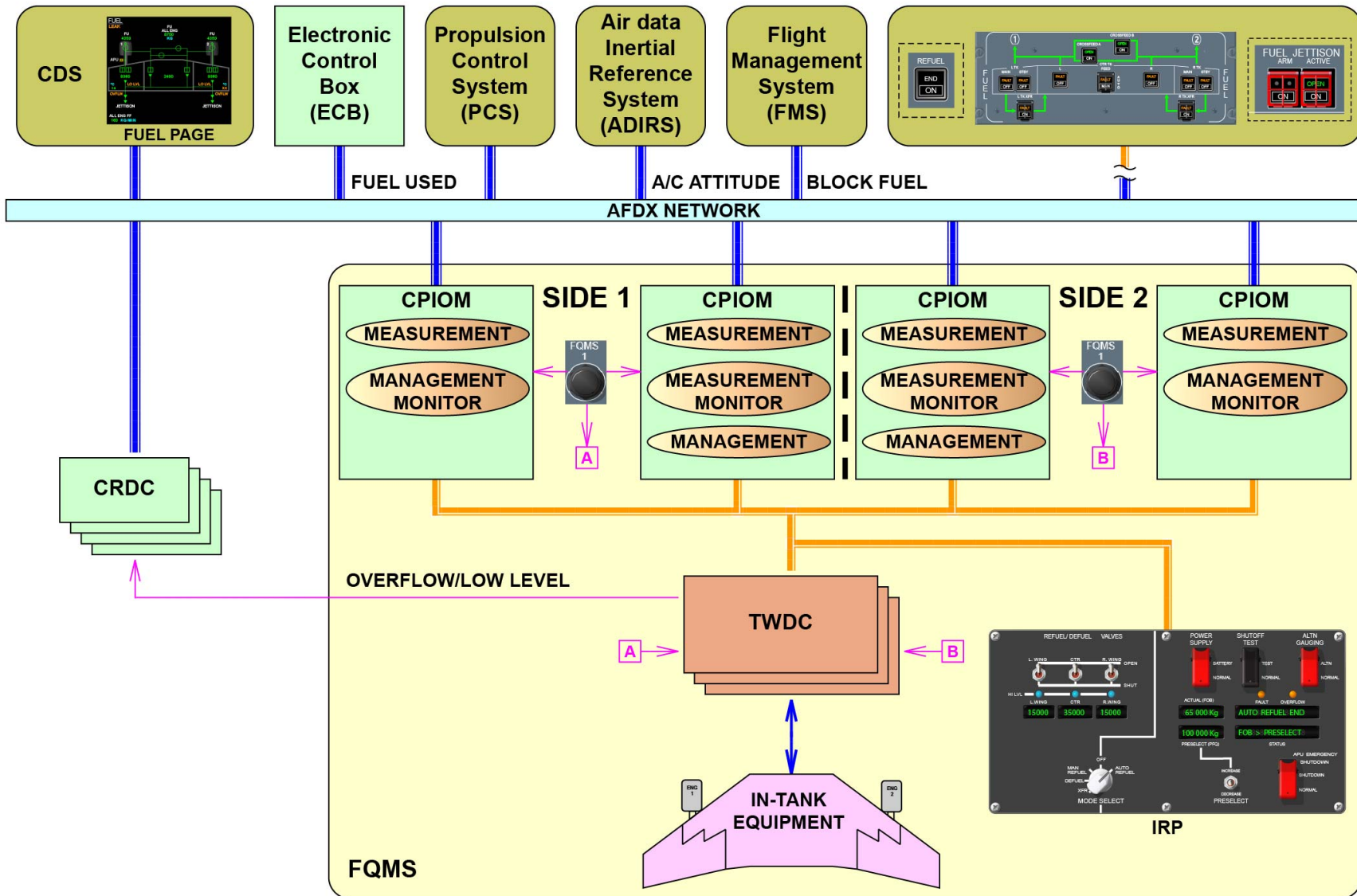

FQMS DESCRIPTION/INTERFACES

V1813401 - V01T0M0 - VM28D3FQMS03001

---

## FUEL QUANTITY MANAGEMENT SYSTEM DESCRIPTION (2/3)

### Components Function/Description

#### In Tank Equipment

The in-tank equipment is electrically energized and monitored by the TWDCs. The capacitance probes are fuel quantity probes that measure the height of the fuel at their locations. The height of the fuel at the different locations is used by the fuel applications to calculate the fuel volume in the different tanks. The Probe Dual Temperature (PDT) units measure:

- The fuel temperature at their locations (when immersed)
- The height of the fuel (when not fully immersed).

PDTs are installed vertically in a position where they are fully immersed at most fuel quantities. The fuel temperatures from the PDTs are used by the fuel applications to calculate the fuel density and permittivity in each tank.

The Fuel Properties Measurement Units (FPMUs), connected to the refuel gallery (not shown), measure the fuel properties for the uplifted fuel during refuel. The uplifted fuel properties are:

- Fuel density
- Fuel permittivity
- Fuel temperature.

The point level sensors sense the presence/absence of the fluid at a given level, independently of the CPIOMs FQMS software. They are used to detect overflow and to validate critical fuel levels (low levels, minimum level necessary for Extended Range Twin Engine Operations (ETOPS) diversion).

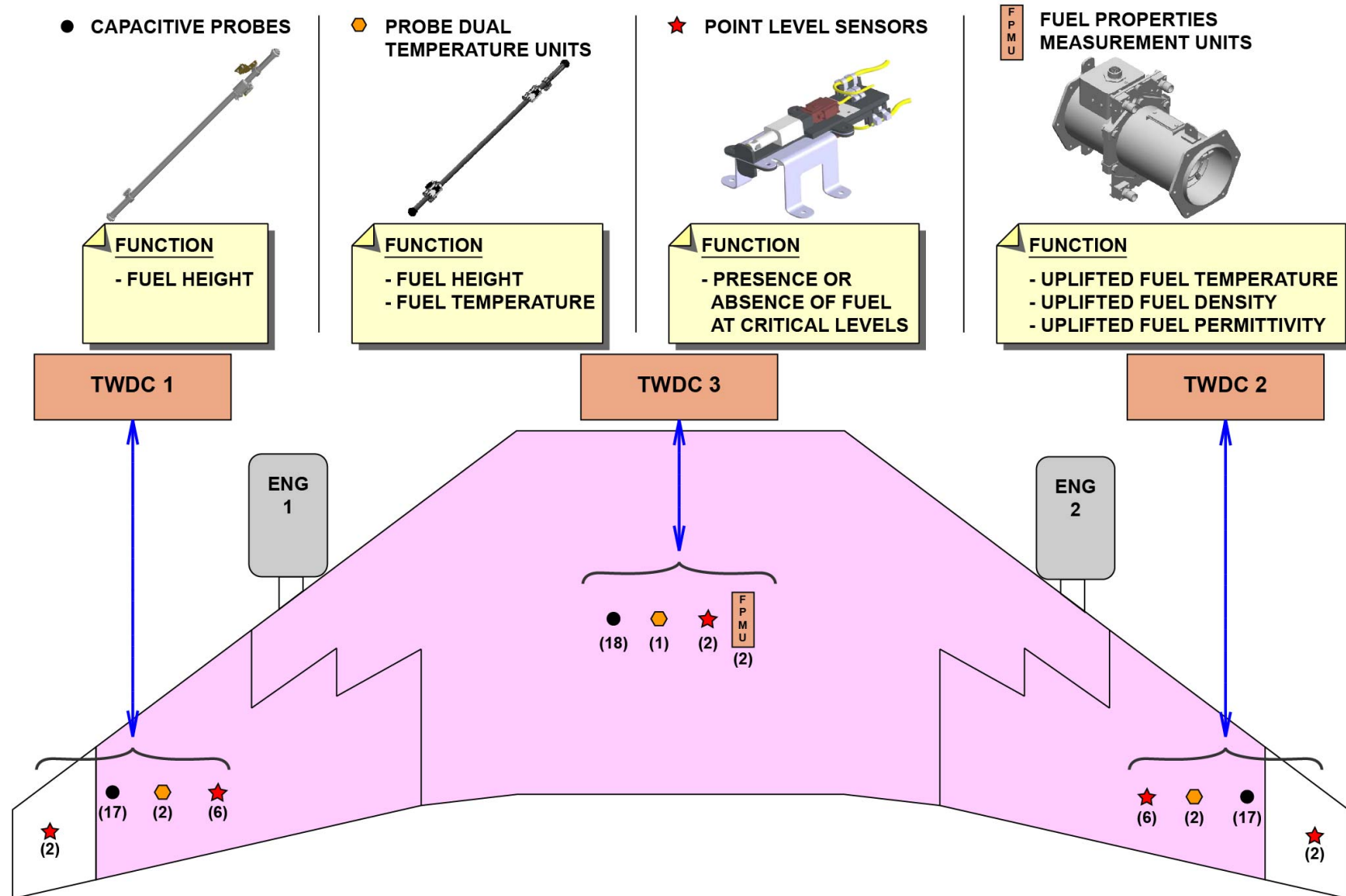

COMPONENTS FUNCTION/DESCRIPTION - IN TANK EQUIPMENT

V1813401 - V01T0M0 - VM28D3FQMS03001

---

## FUEL QUANTITY MANAGEMENT SYSTEM DESCRIPTION (2/3)

### Components Function/Description (continued)

#### **Tank Wall Data Concentrator**

TWDCs electrically energize and receive data from:

- Capacitance probes
- PDTs
- FPMUs
- Point level sensors.

They change the data into digital format for transmission to:

- The CPIOMs fuel applications
- The AFDX network through CRDC for point level sensor data as CPIOMs back-up
- The IRP.

Each TWDC, one for each tank, contains two processing channels A and B which operate independently. Each channel includes a Tank Signalling Processor (TSP) with dedicated software and a Point Level Sensor Processor (PLSP), also with dedicated software.

Each TSP gets data for its related fuel tank from capacitance probes, PDTs and FPMUs (for the center tank). These data are available for the FQMS software in CPIOMs to calculate the fuel quantities. As a back-up for the CPIOMs fuel applications, for maintenance only, the TSPs also calculate the tank fuel quantities which are shown only on the IRP. This back-up function is the Ground Fuel Level Indication (GFLI).

Each PLSP gets data from its related point-level sensor to transmit critical fuel level data to the fuel measurement function of the CPIOMs and independently to the AFDX through the CRDCs. Each TWDC is related to an area: TWDC 1 for the left wing tank, TWDC 3 for the center tank, TWDC 2 for the right wing tank.

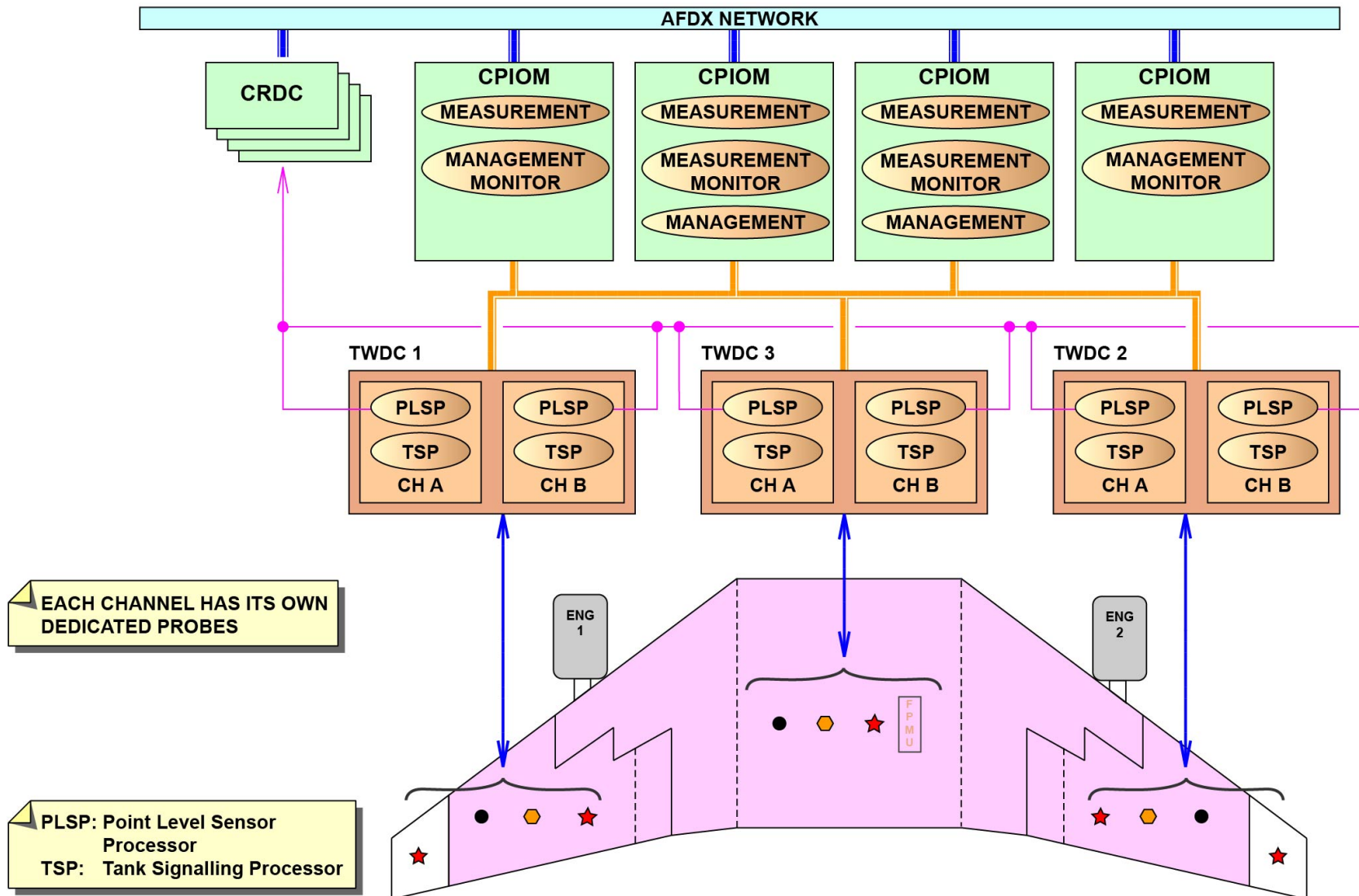

COMPONENTS FUNCTION/DESCRIPTION - TANK WALL DATA CONCENTRATOR

V1813401 - V01T0M0 - VM28D3FQMS03001

---

## FUEL QUANTITY MANAGEMENT SYSTEM DESCRIPTION (2/3)

### Components Function/Description (continued)

#### **Integrated Refuel Panel**

The IRP is a panel installed on the lower side of the aft belly fairing. It is used to show the fuel tank quantities calculated by the CPIOM fuel applications. If a GFLI function is operated with a dedicated switch on the IRP, it also shows the fuel tank quantities calculated by the TWDC TSPs. The measurement accuracy is lower than the measurement accuracy of the CPIOM fuel application. The GFLI is used for aircraft dispatch under MMEL requirements.

The IRP is energized and illuminated when the IRP access door is open. The IRP shows:

- The fuel quantities for each tank
- The total fuel on board.

FUEL QUANTITY VALUES CAN BE DISPLAYED IN KG OR LBS

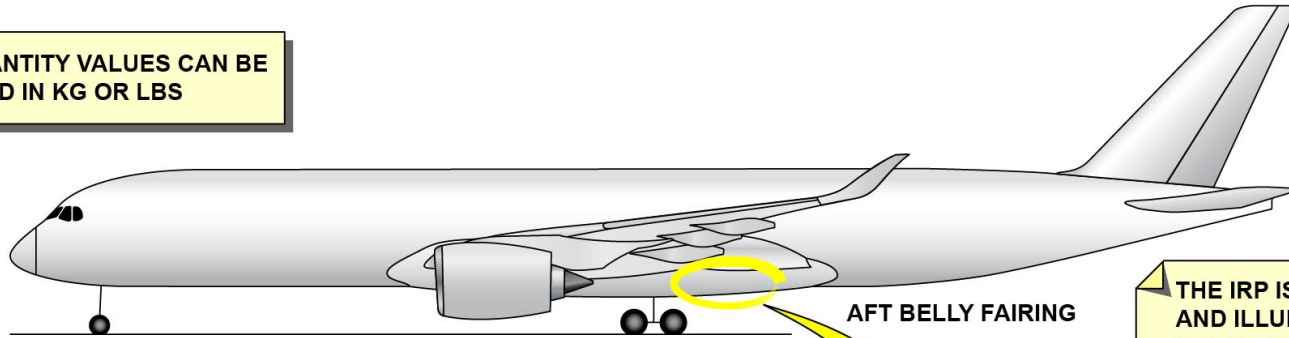

THE IRP IS POWERED AND ILLUMINATED ONLY WHEN THE IRP ACCESS DOOR IS OPEN!

GFLI: Ground Fuel Level Indication

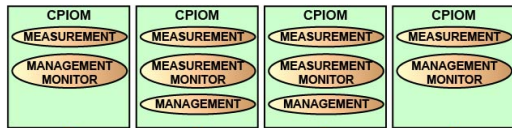

GFLI FUNCTION

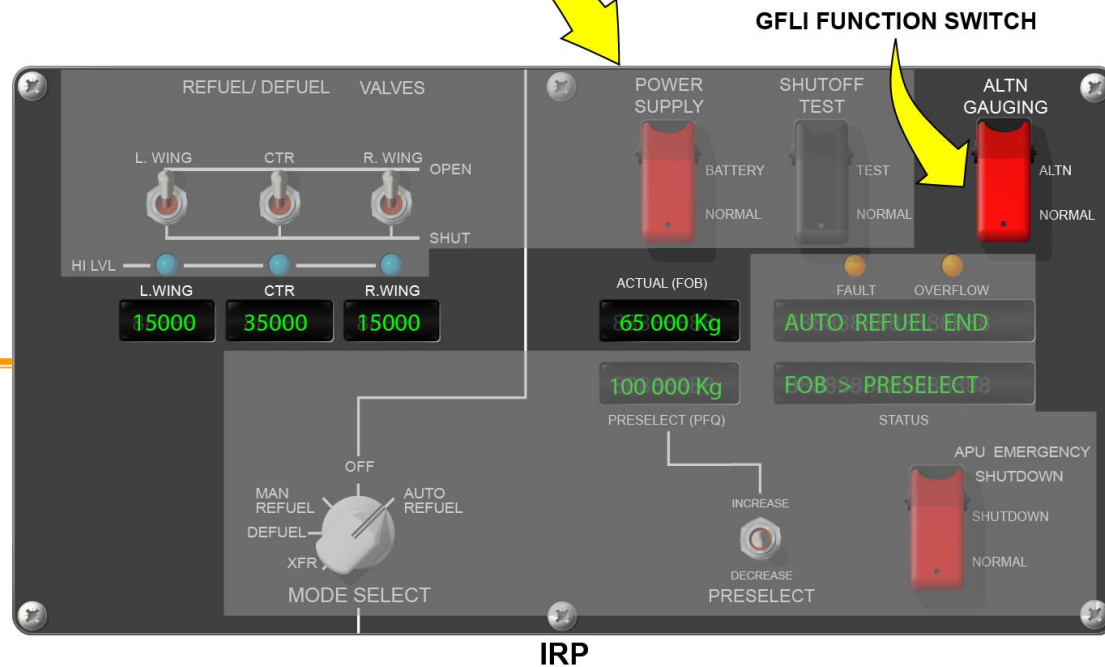
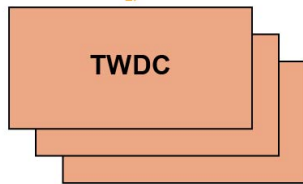

COMPONENTS FUNCTION/DESCRIPTION - INTEGRATED REFUEL PANEL

V1813401 - V01T0M0 - VM28D3FQMS03001

## ENGINE FEED SYSTEM DESCRIPTION (2/3)

### Presentation of the Engine Feed System

The function of the engine feed system is to supply fuel from the collector box to the engines. The engine feed system has:

- An engine feed gallery
- Center-tank fuel pumps (2)
- Wing-tank main fuel pumps (2), one for each wing fuel tank
- Wing-tank standby fuel pumps (2), one for each wing fuel tank
- Low-pressure shut-off valves (2) (operated by a dual-power supply actuator), one for each engine
- Crossfeed valves (2) (operated by a single-power supply actuator).

The fuel is pressurized by the fuel pumps and sent to the engines through the low-pressure shut-off valves. The crossfeed system lets any of the left or right fuel pumps supply fuel to the left or right engine. The fuel pressure switches give information to monitor the fuel pumps. There is one fuel pressure switch for each fuel pump.

To prevent large quantities of water at the bottom of the tanks, water-scavenge jet pumps are used. To operate, the water-scavenge jet pumps use a motive flow from the related engine feed pumps. The water-scavenge jet pumps is then sent to the entrance of the related engine feed pump. A mixture of fuel/water then supplies the engines.



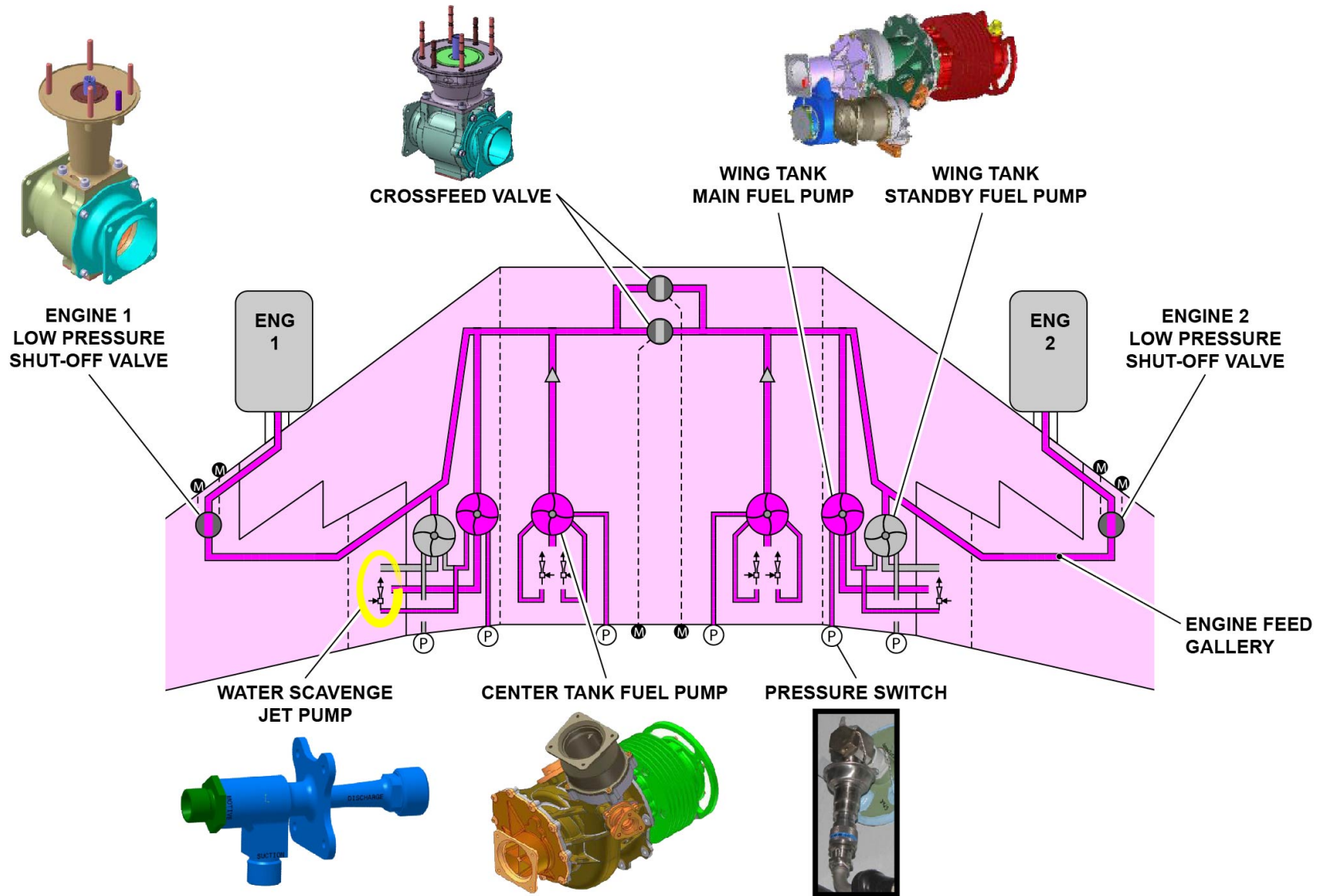

**PRESENTATION OF THE ENGINE FEED SYSTEM**

V1813401 - V01T0M0 - VM28D4ENGFD3001

## ENGINE FEED SYSTEM DESCRIPTION (2/3)

### Description of the Engine Feed System Control

The engine feed system is manually controlled by an Integrated Control Panel (ICP) or automatically controlled by the Fuel Quantity and Management System (FQMS) through:

- Solid State Power Controllers (SSPCs)
- Remote Control Circuit Breakers (RCCBs).

The center-tank fuel pumps are:

- Automatically controlled (through the RCCBs)
- Manually controlled (through the RCCBs).

The main fuel pumps of the wing tank are:

- Manually controlled (through the RCCBs).

The standby fuel pumps of the wing tank are:

- Automatically controlled (through the RCCBs and the SSPCs)
- Manually controlled (through the RCCBs and the SSPCs).

The crossfeed valves are:

- Automatically controlled by the Primary and Secondary computers (PRIMs/SECs) (through relays)
- Manually controlled (direct link between the ICP and the crossfeed valves).

The low-pressure shut-off valves are:

- Manually controlled (through relays).

Some CRDCs are an interface between the engine feed system components and the AFDX network, to give the feedback to the FQMS.

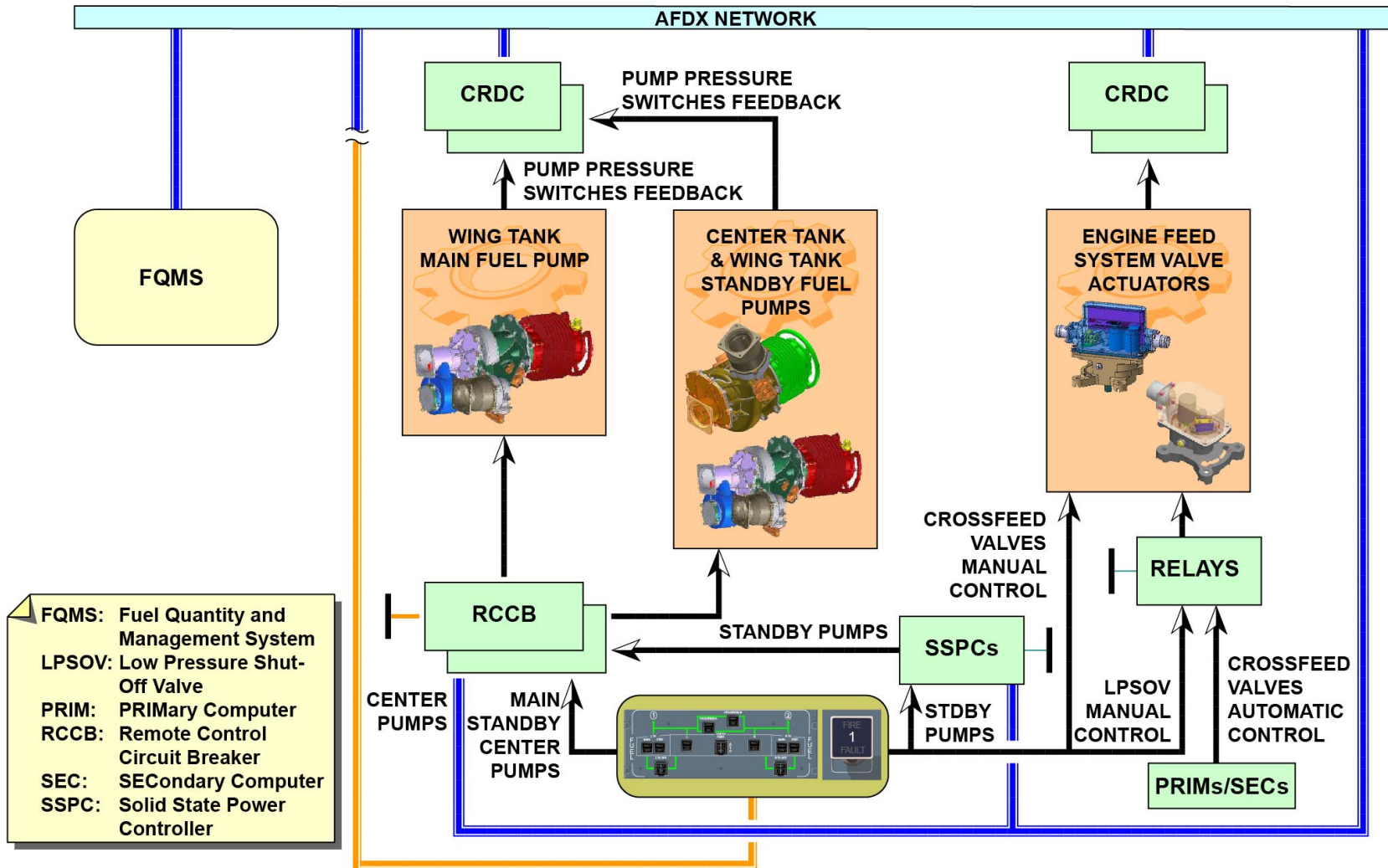

**FQMS:** Fuel Quantity and Management System  
**LPSOV:** Low Pressure Shut-Off Valve  
**PRIM:** PRIMary Computer  
**RCCB:** Remote Control Circuit Breaker  
**SEC:** SECondary Computer  
**SSPC:** Solid State Power Controller

DESCRIPTION OF THE ENGINE FEED SYSTEM CONTROL

V1813401 - V01T0M0 - VM28D4ENGFD3001

## ENGINE FEED SYSTEM DESCRIPTION (2/3)

### Description of the Center-Tank Fuel Pumps

The center-tank fuel pumps have a fuel pump element in a canister. On the fuel pump element, a drain plug is used to drain the canister before you fully remove the fuel pump element.

The center-tank fuel pumps are electrically energized through the Fixed Frequency Supply Units (FFSUs). Each FFSU contains a Ground Fault Interruption (GFI) function, to prevent ground faults with a possible ignition source. The FFSU disconnects the power to the related center-tank fuel pump if it finds current leakage to the ground. Each FFSU also has a TEST and RESET switch to do and reset a manual current-leakage simulation. There is a visual indication for current leakage.

The center-tank pumps are usually controlled by the FQMS, but there is a manual override function. They are energized through the FFSUs when the applicable center-tank pump pushbuttons are set to ON. The center-tank fuel pumps are set to ON and automatically controlled when:

- The related pump pushbutton is set to ON at the ICP
- The flaps/slats control lever is set to the ZERO position
- The center-tank empty status is found to be NOT EMPTY.

During the take-off flight phase (or landing with fuel in the center fuel tank), the FQMS automatically stops the center-tank fuel pumps. This is to make sure that there is no contamination in the fuel supplied to the two engines during this critical flight phase. The FQMS uses the slat/flap extension data from the Slat Flap Control Computer (SFCC) interface to know if the aircraft is in take-off phase.

The center-tank pumps operate continuously when the related ICP pushbutton is pushed and the manual override is set.

The center-tank fuel pumps supply more pressure than the wing-tank fuel pumps, and thus are the first to supply fuel to the engines. One center-tank fuel pump keeps sufficient pressure and flow to keep the fuel supply to the two engines, in preference to the wing-tank fuel pumps, if the crossfeed valves are opened.

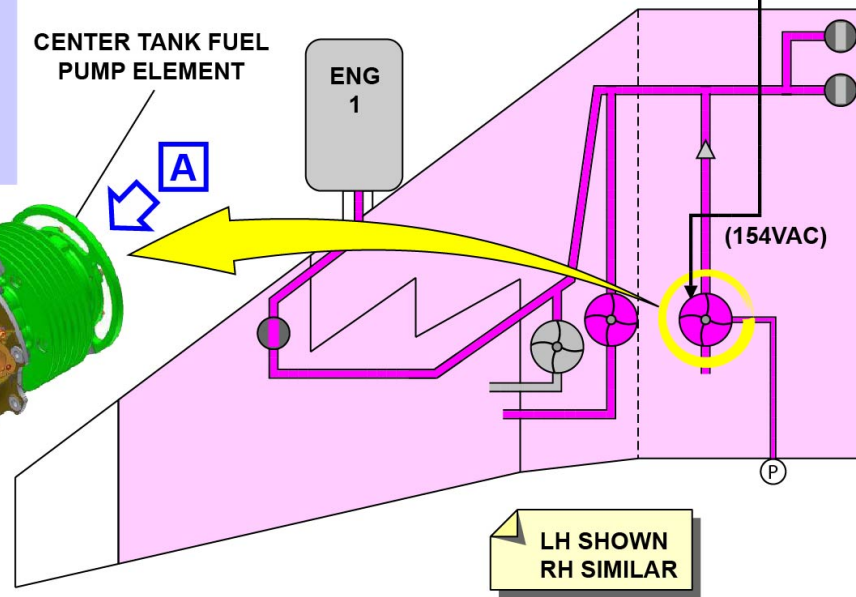
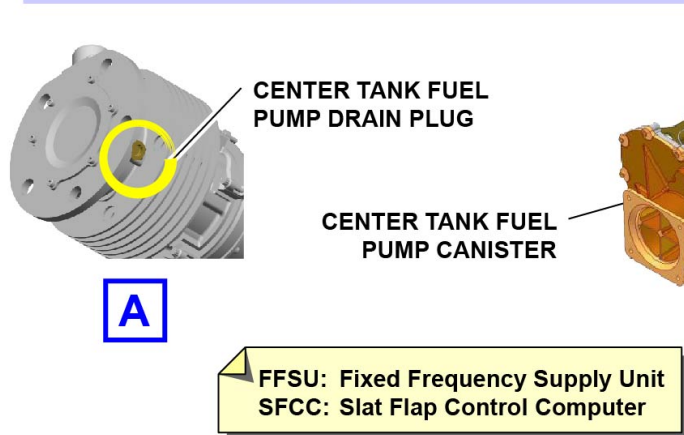
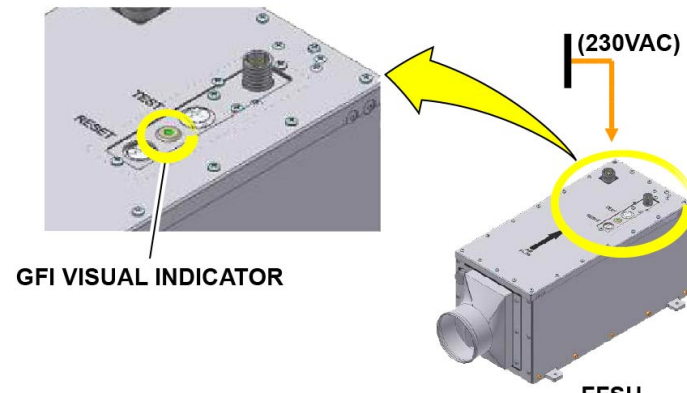
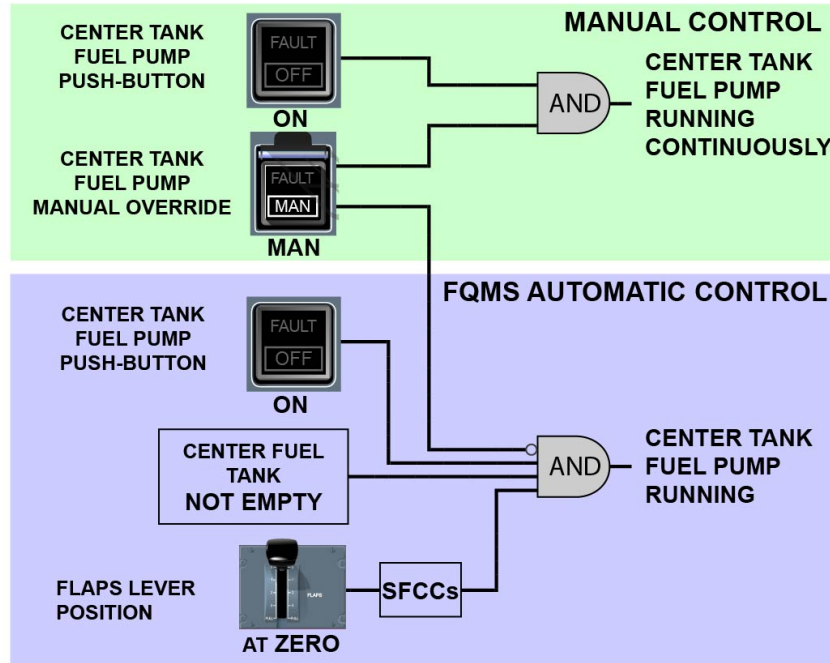

DESCRIPTION OF THE CENTER-TANK FUEL PUMPS

V1813401 - V01T0M0 - VM28D4ENGFD3001

---

## ENGINE FEED SYSTEM DESCRIPTION (2/3)

### Description of the Wing Tanks Fuel Pumps

#### Main Pumps

The MAIN fuel-pumps elements and the standby fuel-pump elements of the wing tanks are inserted in a canister. The MAIN and STANDBY fuel pumps have the protection of a pump protective cage. The pumps and canisters are all assembled by the same procedure and are interchangeable. A drain plug is installed to let the fuel to be drained from the canister before you fully remove the pump element.

The MAIN fuel pumps of the wing tanks are manually controlled only. There is no automatic control. The MAIN fuel pumps of the wing tanks are set to ON and manually controlled when:

- The related pump pushbutton is set to ON at the ICP
- The aircraft is not in Emergency Electrical Configuration (EEC) during the landing phase.

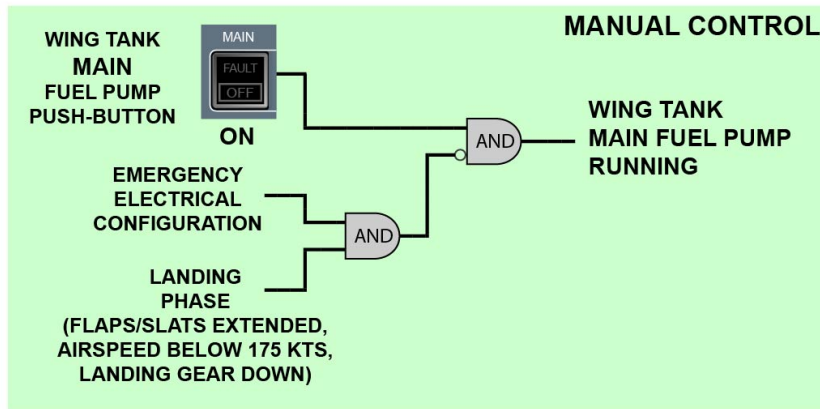

**NO AUTOMATIC CONTROL FOR THE WING TANK MAIN FUEL PUMPS!**

### MAIN PUMP OPERATION

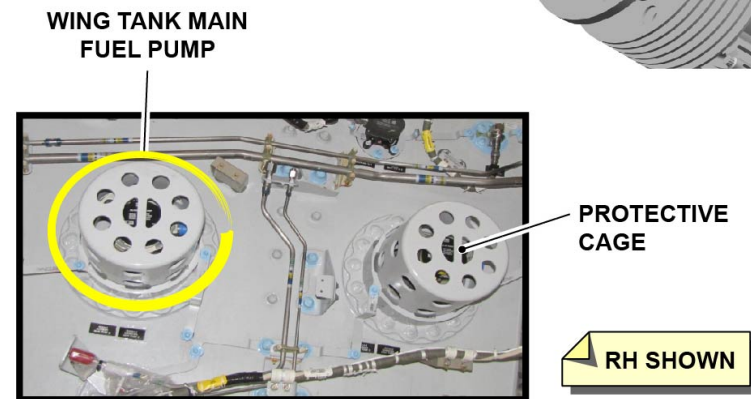
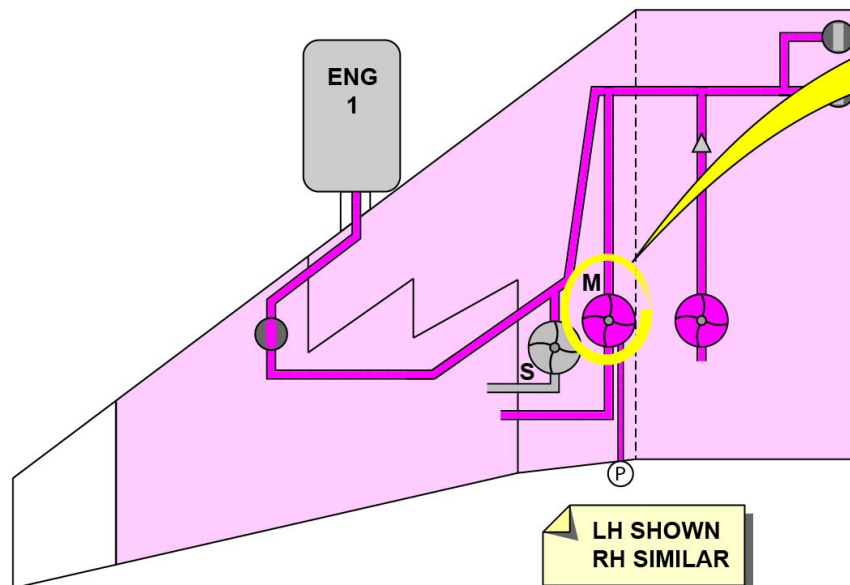
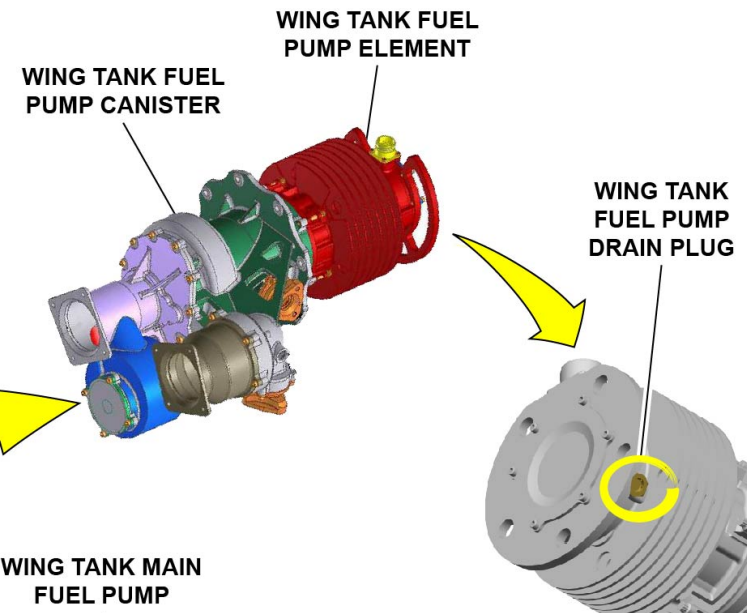

### DESCRIPTION OF THE WING TANKS FUEL PUMPS - MAIN PUMPS

V1813401 - V01T0M0 - VM28D4ENGFD3001

---

## ENGINE FEED SYSTEM DESCRIPTION (2/3)

### Description of the Wing Tanks Fuel Pumps (continued)

#### Standby Pumps

The STANDBY fuel pumps of the wing tanks are manually controlled in normal operation and automatically controlled for test only during a short period (5 minutes). This test is done to make sure that the standby engine feed-pumps, the related pressure switches and the control circuits operate correctly before each flight, and to remove water collected in the pump.

**MANUAL CONTROL:** The STANDBY fuel-pumps of the wing tanks are set to ON and manually controlled when:

- The applicable pump pushbutton is set to ON at the ICP.
- And either the related MAIN pump pushbutton is set to OFF at the ICP.
- Or there is no working pressure sensed for the related MAIN fuel-pump of the wing tank (data from the related-pressure switch).

**AUTOMATIC CONTROL:** for test only. The STANDBY fuel-pumps of the wing tanks are set to ON and automatically controlled when:

- The related pump pushbutton is set to ON at the ICP.
- The ground/flight status is GROUND.
- The FWS flight phase is 1 (pre-flight) or 2 (taxi-out).
- The STANDBY pump status is not OFF or there is no low pressure sensed by the pressure switch.



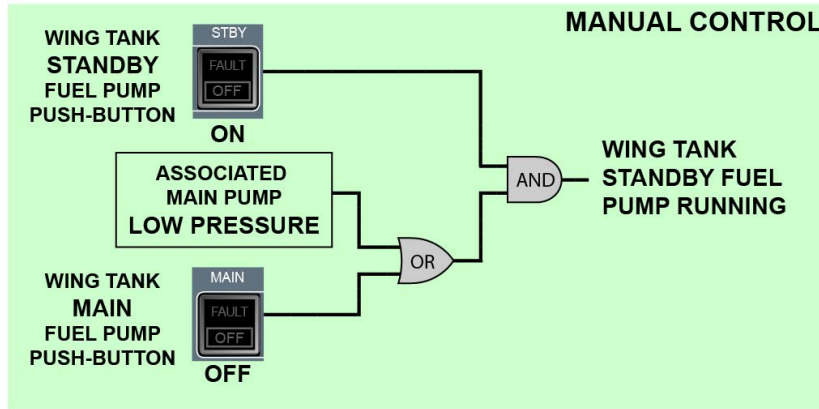

STANDBY PUMP NORMAL OPERATION

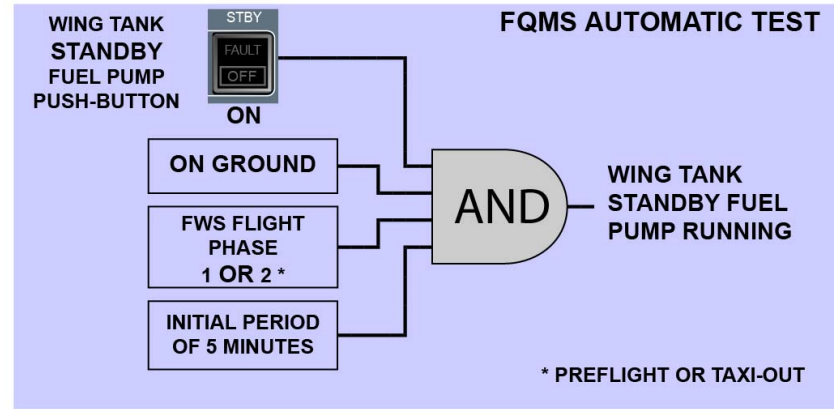

STANDBY PUMP AUTOMATIC OPERATION

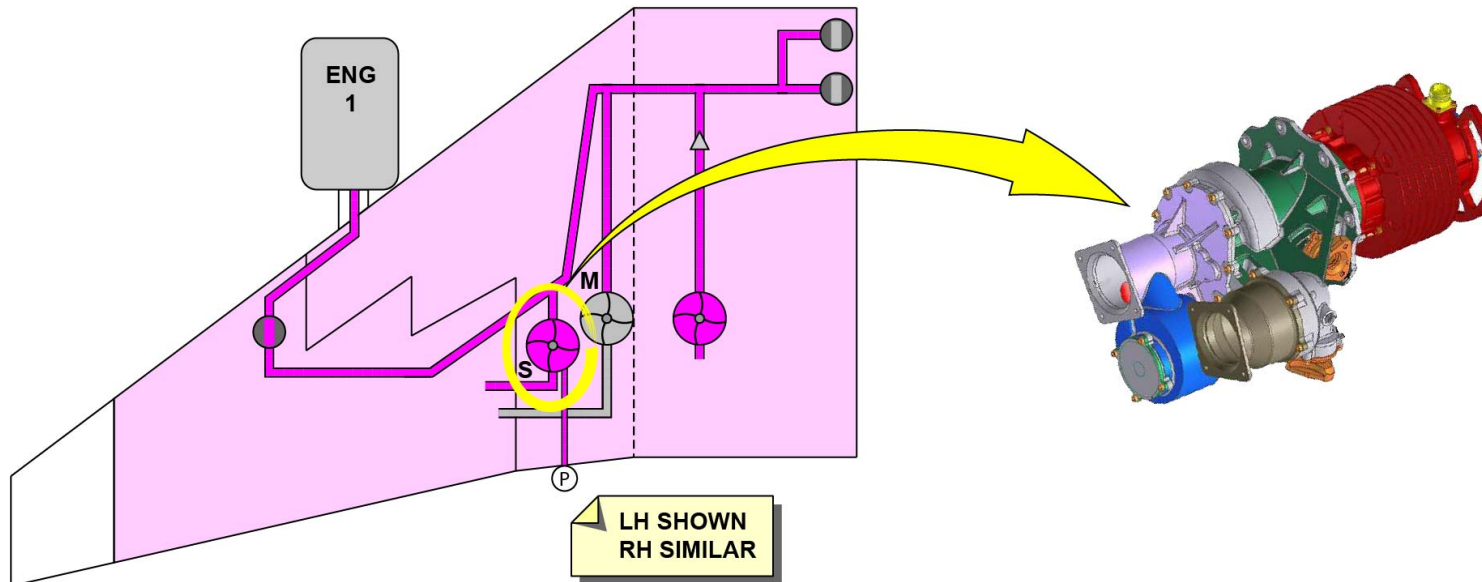

DESCRIPTION OF THE WING TANKS FUEL PUMPS - STANDBY PUMPS

V1813401 - V01T0M0 - VM28D4ENGFD3001

## ENGINE FEED SYSTEM DESCRIPTION (2/3)

### Description of the Low-Pressure Shut-off Valves

The function of the low-pressure shut-off valves is to isolate each engine from the fuel feed supply at engine shut-down or if there is an emergency (for example, engine fire). Each low-pressure shut-off valve is operated to the open and closed positions by a dual-power supply actuator. Each dual-power supply actuator has two motors that independently receive an electrical power supply, and a position indicator switch that sends a feedback signal to give the actuator position. Each dual-power supply actuator also includes a mechanical visual position-indicator for maintenance functions. The dual-power supply actuators are installed in fireboxes for temperature protection.

The low-pressure shut-off valves are manually controlled. In usual operation, they are manually:

- Controlled OPEN when the engine master switch is ON
- Controlled CLOSED when the engine master switch is OFF.

The selection of the engine FIRE push-button overrides the related engine master-switch command in the ON position and causes the low-pressure shut-off valve to close.

**CAUTION: WHEN THE AIRCRAFT IS ELECTRICALLY DE-ENERGIZED, THE LOW-PRESSURE SHUT-OFF VALVE GOES TO ITS OPEN FAIL-SAFE POSITION.**

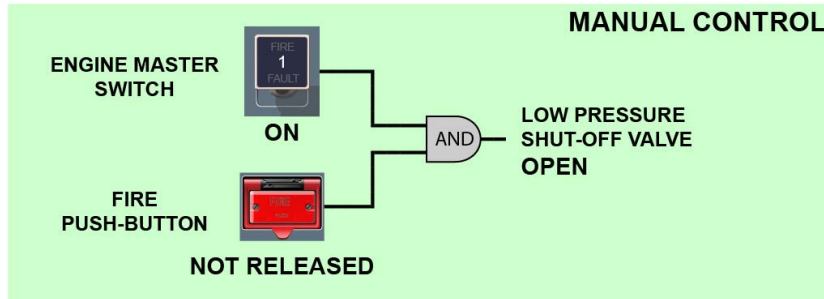

THE LOW PRESSURE SHUT-OFF VALVE IS OPEN WHEN THE AIRCRAFT IS ELECTRICALLY DE-ENERGIZED

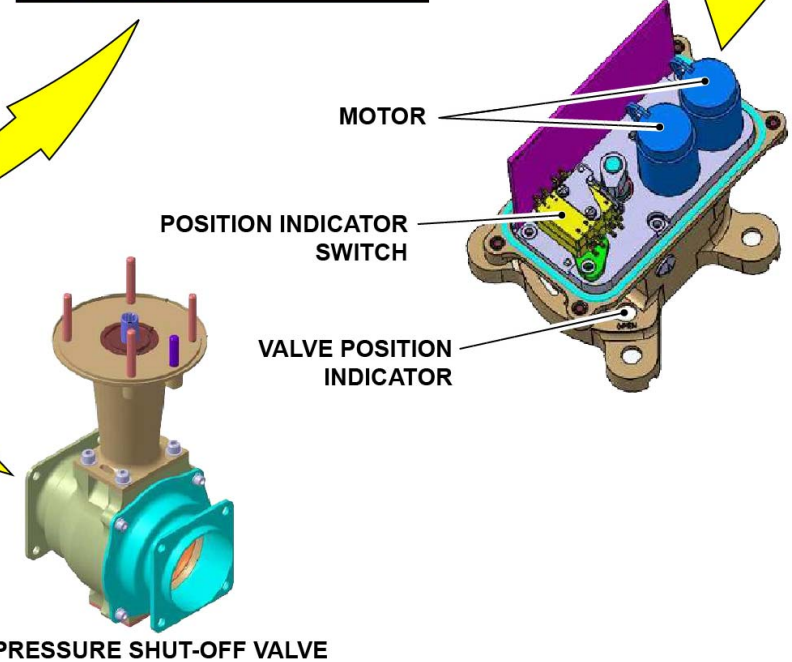
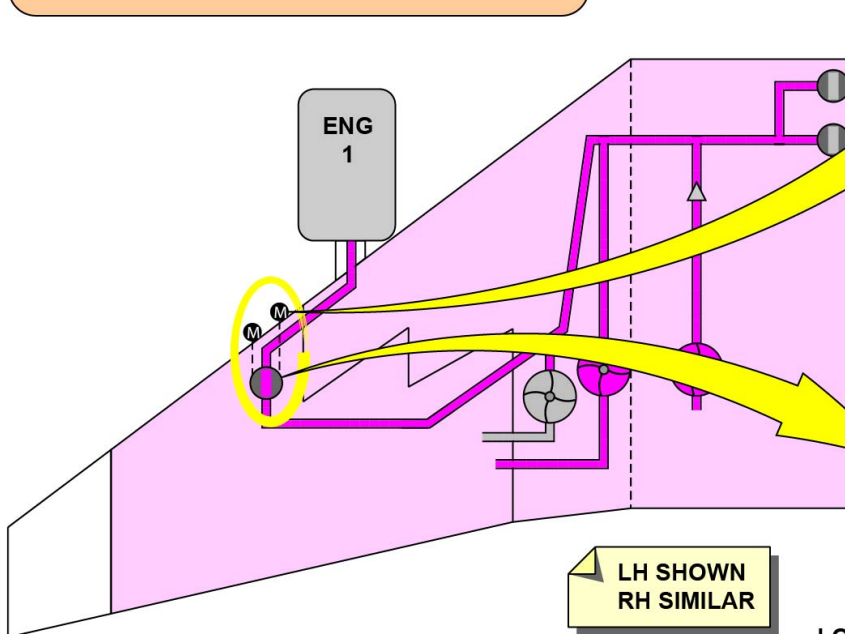
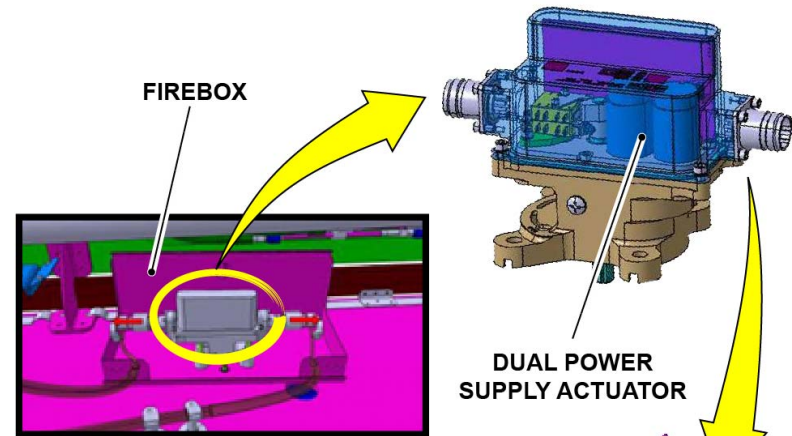

DESCRIPTION OF THE LOW-PRESSURE SHUT-OFF VALVES

V1813401 - V01T0M0 - VM28D4ENGFD3001

---

## ENGINE FEED SYSTEM DESCRIPTION (2/3)

### Description of the Crossfeed Valves

The crossfeed system has:

- Two crossfeed valves connected to the engine feed gallery
- Two single-power supply actuators.

Each single-power supply actuator has one motor and a position indicator switch that sends a feedback signal to give the actuator position. Each single-power supply actuator also includes a mechanical visual position-indicator for deactivation. If there is a failure, it is possible to set the actuator manually and to lock it in the closed position with the mechanical visual position-indicator.

The two crossfeed valves are connected in parallel. In usual operation, the crossfeed valves are set to OPEN when their related pushbutton is set to ON at the ICP. In emergency electrical configuration, the two crossfeed valves are automatically set to OPEN.

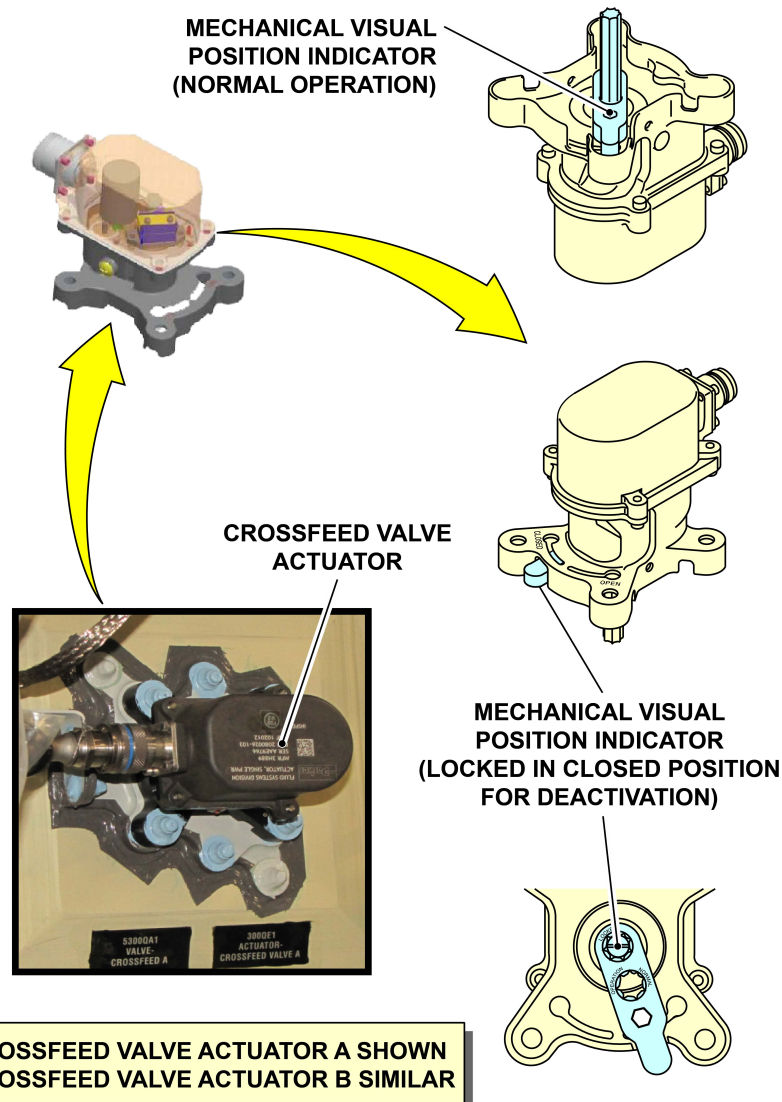
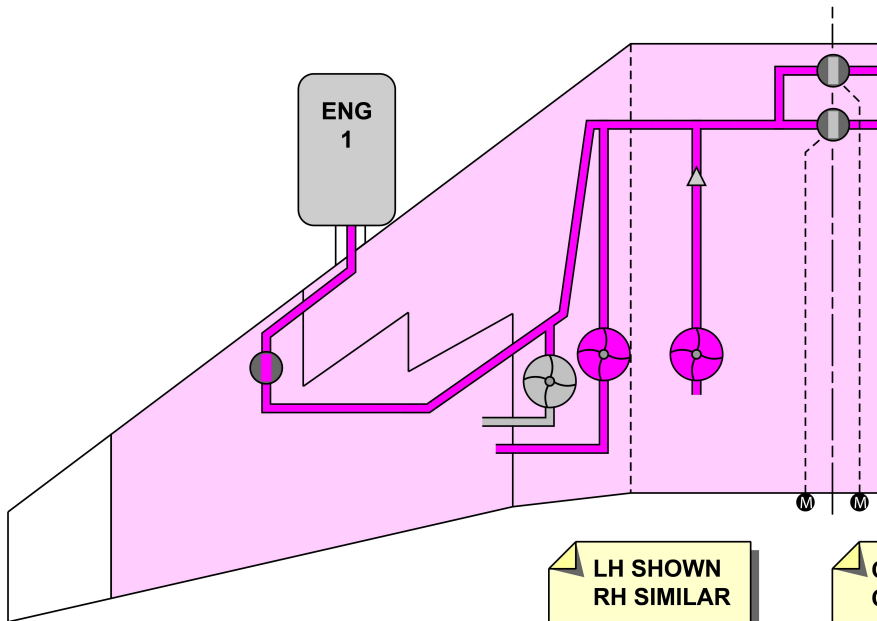
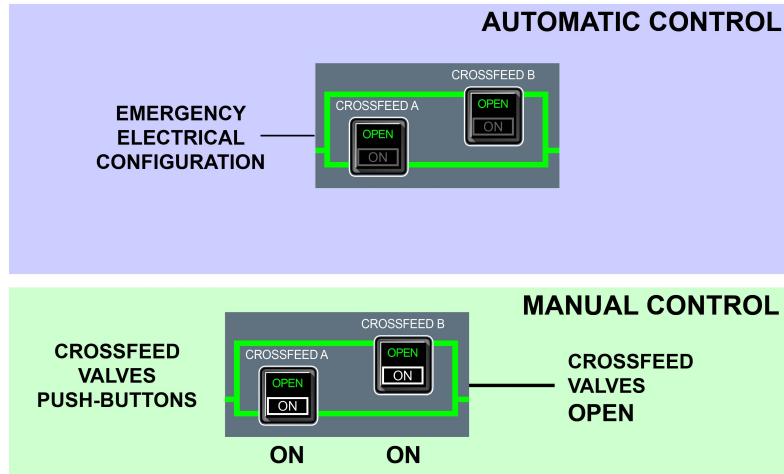

DESCRIPTION OF THE CROSSFEED VALVES

V1813401 - V01T0M0 - VM28D4ENGFD3001

## ENGINE FEED SYSTEM DESCRIPTION (2/3)

### Description of the Fuel Scavenge System

A fuel scavenge system in the center fuel tank decreases the unusable volume of fuel for the center-tank to a minimum. The system uses fuel scavenge jet pumps (4), which are installed to collect fuel from the lowest points of the center fuel tank. The motive flow for the fuel scavenge system is supplied by the wing engine-feed pumps, through the related left fuel-scavenge valve and the right fuel-scavenge valve. Scavenged fuel is sent back to the related wing fuel tank.

The fuel scavenge valve is a two-position valve (fully open or fully closed) operated by a single-power supply actuator. Each single-power supply actuator has one motor and a position indicator switch that sends a feedback signal to give the actuator position. Each single-power supply actuator also includes a mechanical visual position-indicator for deactivation. If there is a failure, it is possible to set the actuator manually and to lock it in the closed position with the mechanical visual position-indicator.

The fuel scavenge system is automatically controlled by the FQMS. The FQMS will start a scavenge cycle in one of the conditions that follows:

- The center fuel tank becomes empty in flight
- The wing fuel tanks are at a low level.

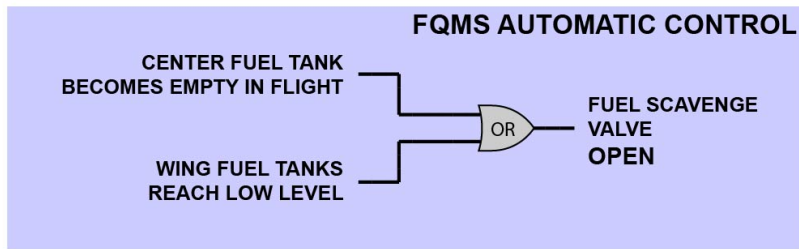

IN CASE OF FAILURE, THE ACTUATORS OF THE FUEL SCAVENGE VALVES ARE DEACTIVATED (SIMILAR TO CROSS-FEED VALVES)

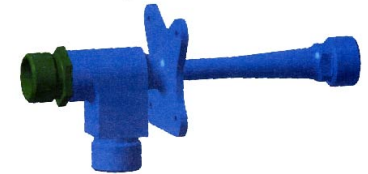
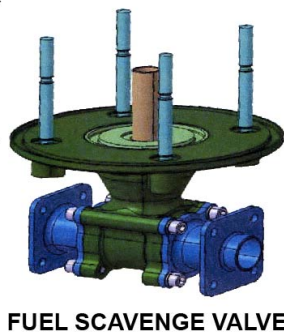
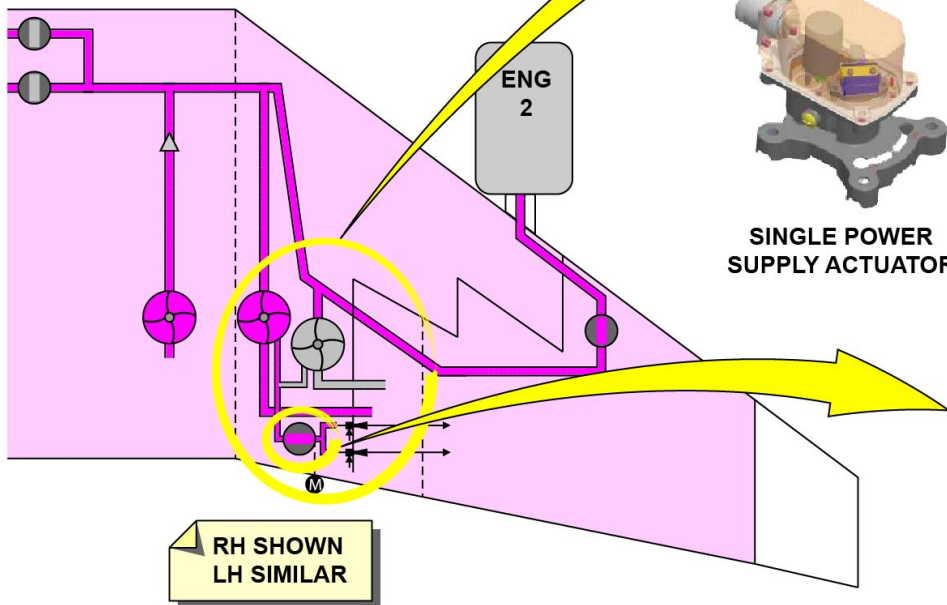
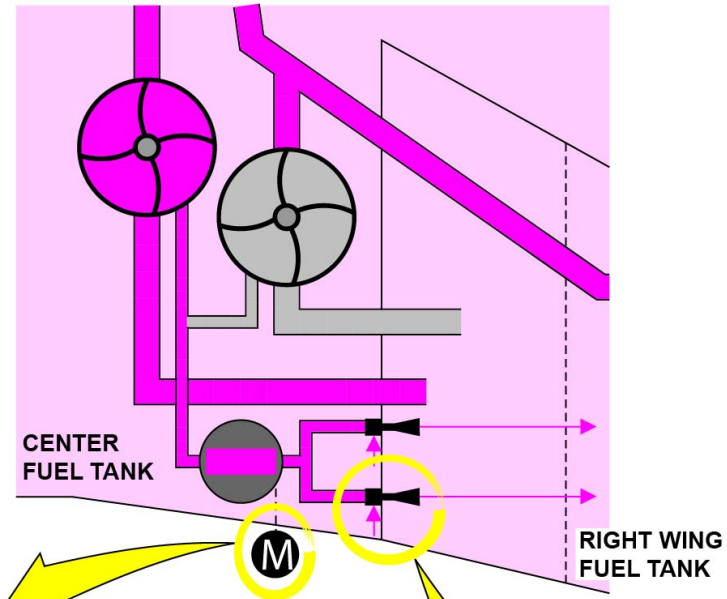

DESCRIPTION OF THE FUEL SCAVENGE SYSTEM

V1813401 - V01T0M0 - VM28D4ENGFD3001

## APU FEED SYSTEM DESCRIPTION (2/3)

### APU Feed System Function/Description

The function of the APU fuel-feed system is to supply fuel to the APU in all operating conditions. The APU fuel-feed system has:

- A shrouded APU fuel-feed pipe
- An APU fuel pump
- An APU isolation valve
- An APU low-pressure valve
- An APU drain and vent valve.

When the APU is not in operation, the APU fuel-isolation valve and the APU fuel low-pressure valve are closed and the APU fuel pump is off. In usual operation, the fuel is supplied from the left side of the engine feed gallery to the APU. The APU fuel pump supplies the necessary fuel pressure. If this is not sufficient, fuel pressure is supplied by the engine fuel-feed pumps. Fuel pressure is monitored through a pressure switch. The fuel flows from the engine feed system to the APU fuel-feed system through a connection at the engine crossfeed line. A shrouded fuel-feed line supplies the fuel to the APU. The APU isolation valve and the APU low-pressure valve allow or prevent the fuel flow to the APU. The APU fuel-feed line is monitored by two adjacent wires, to find if the line is damaged or not. If there is damage, the fuel supply to the APU is stopped. To drain the APU feed-pipe shroud, there is a drain pipe from the APU feed-pipe shroud down to the drain mast. This is used by the maintenance personnel to do a check for fuel leaks. The APU feed line is connected to an APU drain port (on the APU Fuel Control Unit (FCU)) and is used to bleed or drain the feed line.



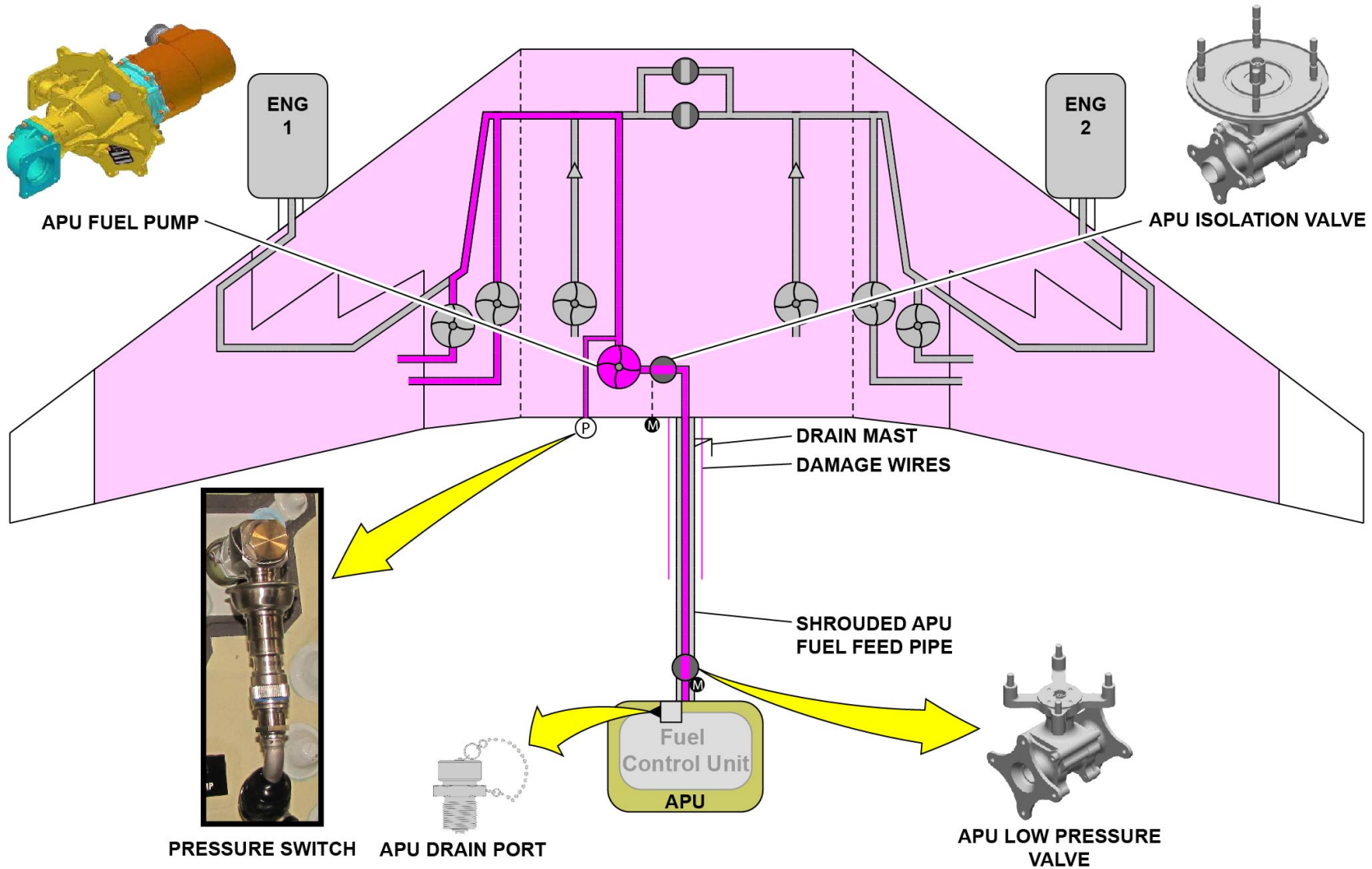

**APU FEED SYSTEM FUNCTION/DESCRIPTION**

V1813401 - V01T0M0 - VM28D5APUFD3001

## APU FEED SYSTEM DESCRIPTION (2/3)

### Description of the APU Feed System Control

The APU is controlled by the APU Electronic Control Box (ECB). When the ECB receives a signal from the APU master switch, it determines that fuel is necessary for the APU and sends a FUEL DEMAND signal. Operation of the APU fuel pump is controlled by a pressure switch, which senses the engine feed-system pressure at the inlet of the pump.

The APU fuel pump is set to ON and the APU isolation valve and the APU low pressure valves are set to OPEN when:

- The APU master switch is set to ON or the APU fuel-vent pushbutton is set to ON
- The APU emergency shutdown switches are not set to SHUT DOWN (on the Integrated Refuel Panel (IRP) and on the Ground Service Panel (GSP)) and the APU fire push-button is NOT SELECTED
- The two APU feed-line damage wires are not damaged
- And, for the APU fuel-pump only, the APU pressure switch senses fuel low pressure from the engine feed gallery.

The CRDCs monitor 2 wires that operate independently and that are parallel to the APU feed line. If the CRDCs sense that one of these two wires becomes an open circuit, it assumes that the APU feed line is damaged. The CRDCs then control, with the relays, the APU isolation valve and the APU low-pressure valve to close, and the APU fuel pump off.

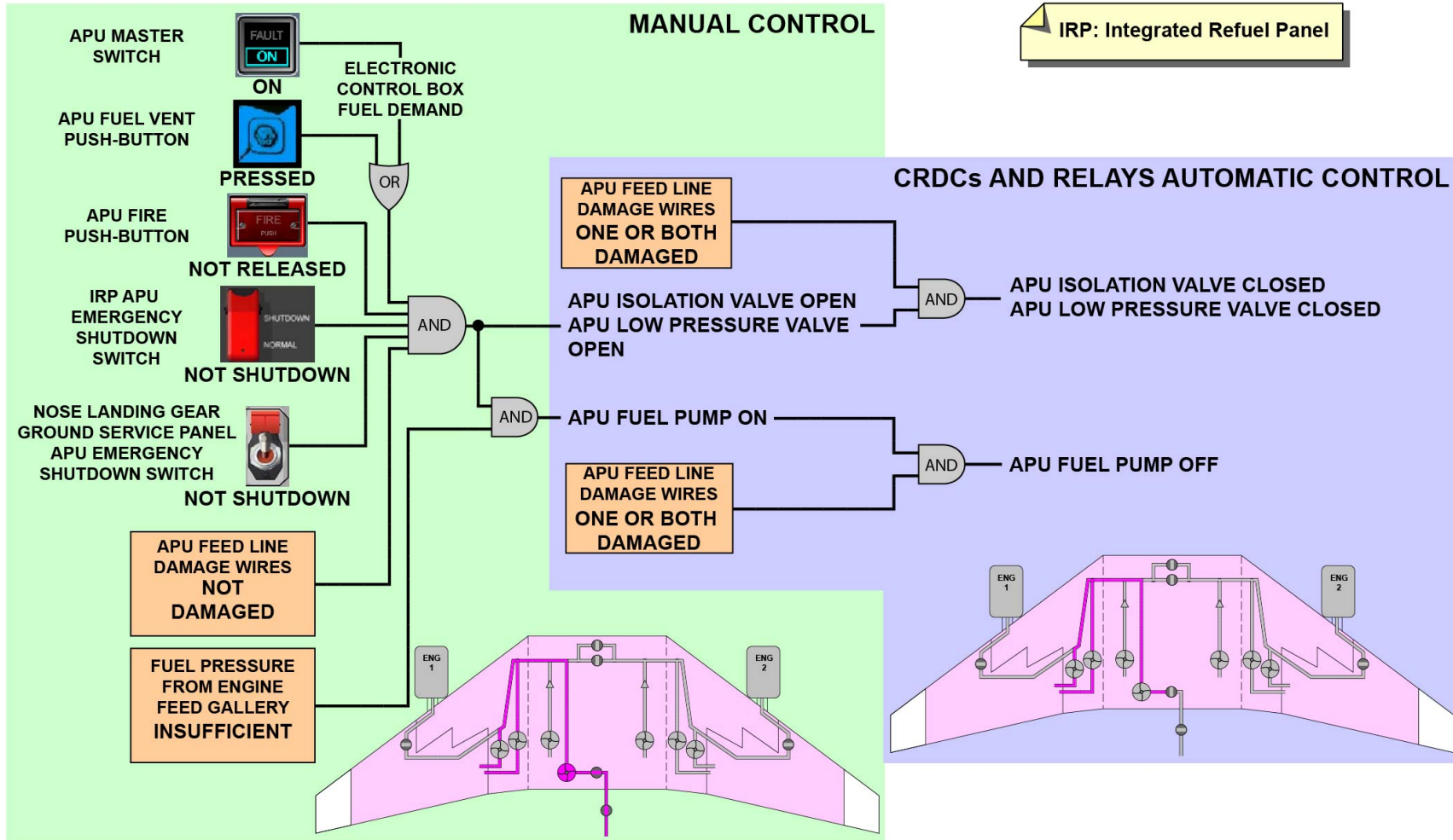

DESCRIPTION OF THE APU FEED SYSTEM CONTROL

V1813401 - V01T0M0 - VM28D5APUFD3001

## APU FEED SYSTEM DESCRIPTION (2/3)

### Components Description

#### **APU Fuel Pump**

The APU fuel pump has a fuel pump element inserted in a canister. The APU fuel pump is a DC pump that is used to battery-start the APU (supplied with a 28 V DC power supply).

#### **APU Fuel Isolation Valve and APU Low Pressure Valve**

The function of the APU isolation valve is to isolate the APU fuel-feed line if there is a damaged APU fuel-feed line. It also prevents the pressurization of the APU fuel-feed line with fuel when the APU is not used. The function of the APU low-pressure valve is to isolate the APU fuel flow. Because this valve is in the APU area, it keeps the fuel quantity to a minimum between the APU feed line and the APU when it is shut-down.

The APU isolation valve and the APU low-pressure valve are operated to the open and closed positions by a single-power supply actuator. Each single-power supply actuator has one motor and a position indicator switch that sends a feedback signal to give the actuator position. Each single-power supply actuator also includes a mechanical visual position-indicator for deactivation. If there is a failure, it is possible to manually turn and lock the valve in the closed position with the mechanical visual position-indicator.

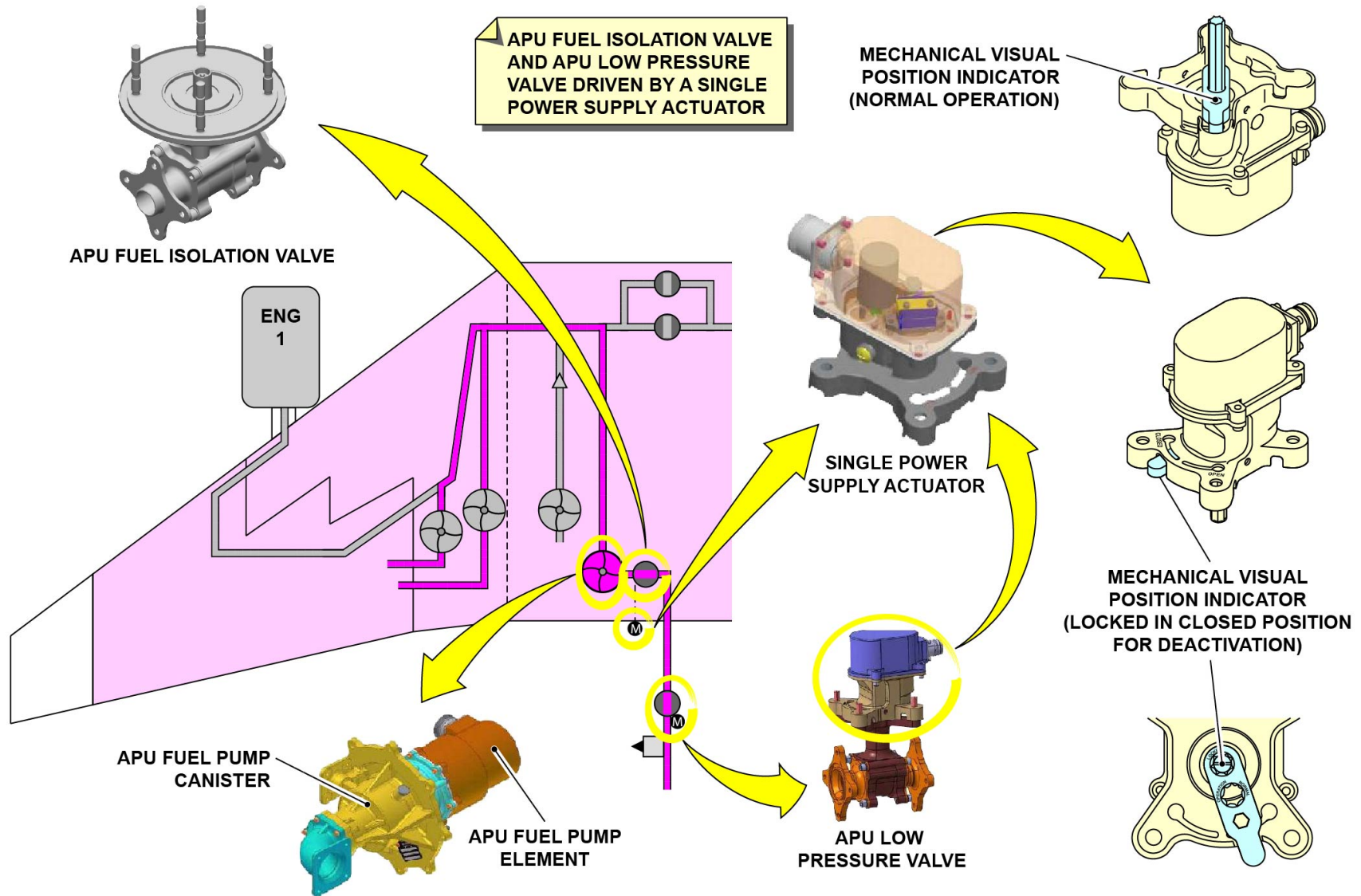

**COMPONENTS DESCRIPTION - APU FUEL PUMP & APU FUEL ISOLATION VALVE AND APU LOW PRESSURE VALVE**

V1813401 - V01T0M0 - VM28D5APUFD3001

---

## REFUEL/DEFUEL/TRANSFER SYSTEM DESCRIPTION (2/3)

### Refuel/Defuel/Transfer System Presentation

The function of the refuel/defuel/transfer system is to add and/or remove and/or transfer the aircraft fuel to/from the tanks. When a pressure refuel source is connected to the aircraft, it is possible to refuel the aircraft:

- Automatically, with the full control of the Fuel Quantity Management System (FQMS)
- Manually, with the control of an operator and the FQMS.

When a receptacle is connected to the aircraft, it is possible to defuel the aircraft manually by:

- Pressure Defuel, which uses the aircraft's pumps as a motive power to push the fuel from the aircraft
- Suction Defuel, which uses an external device to remove the fuel from the aircraft, by suction.

Manual fuel transfers are also possible. The refuel/defuel/transfer system has:

- A right refuel/defuel coupling, which includes a refuel isolation valve plus an optional left refuel/defuel coupling
- A refuel/defuel gallery
- Center tank and wing tank inlet valves
- A right defuel valve (in a basic aircraft configuration, with the optional jettison system not installed).

- POSSIBLE OPERATIONS:**
- AUTOMATIC REFUEL
  - MANUAL REFUEL
  - PRESSURE DEFUEL
  - SUCTION DEFUEL
  - MANUAL TRANSFERS

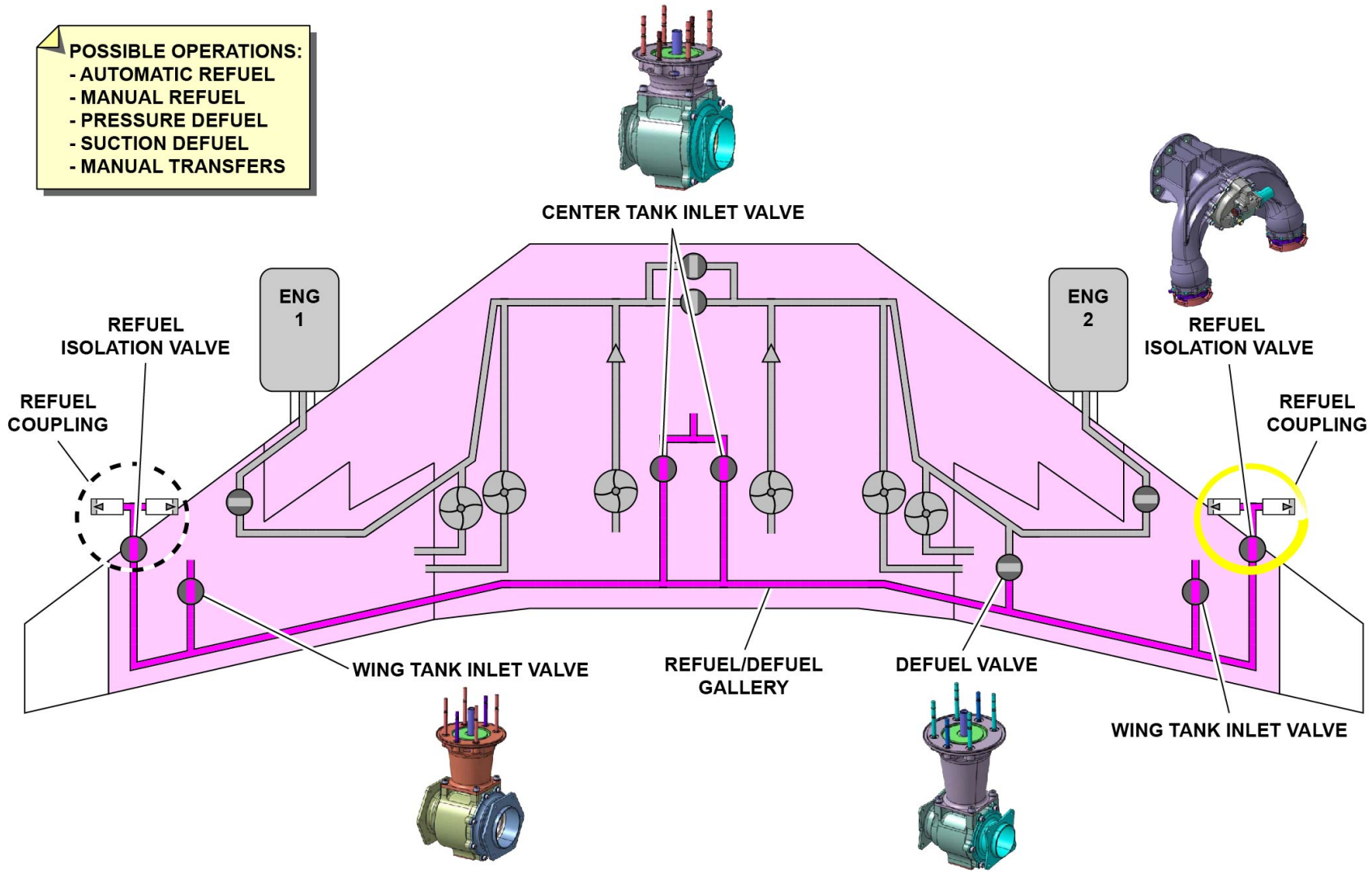

REFUEL/DEFUEL/TRANSFER SYSTEM PRESENTATION

V1813401 - V01T0M0 - VM28D6REFUE3001

---

## REFUEL/DEFUEL/TRANSFER SYSTEM DESCRIPTION (2/3)

### Description of the Refuel/Defuel/Transfer System Components

#### Refuel/Defuel Couplings With Refuel Isolation Valves

In normal configuration, there is only one refuel/defuel coupling on the right-wing leading edge, behind a hinged access panel. It is possible to install an optional second refuel/defuel coupling (and its related refuel gallery pipework) on the left-wing leading edge. The refuel/defuel couplings are connected to one or two standard connectors, through two adaptors. The refuel/defuel coupling adaptor has a check valve in the closed position. When the cockpit refuel option is installed, there is a "Ready to refuel" light, adjacent to the refuel/defuel coupling, to show that cockpit refuel is selected and fuel is necessary.

Each refuel/defuel coupling has a refuel isolation valve to isolate the fuel system from the external sources of fuel pressure. Each refuel isolation valve is operated by fuel pressure and controlled by a solenoid. When the valve is energized and a fuel pressure is applied, it will open. It is possible to use one or the two refuel/defuel coupling adaptors for refuel and defuel. The refuel isolation valve has a manual override button, to control the valve if it does not open when electrical power is supplied. When the manual override button is used as an alternative to electrical power, refuel or defuel pressure continues to be necessary to open the valve.



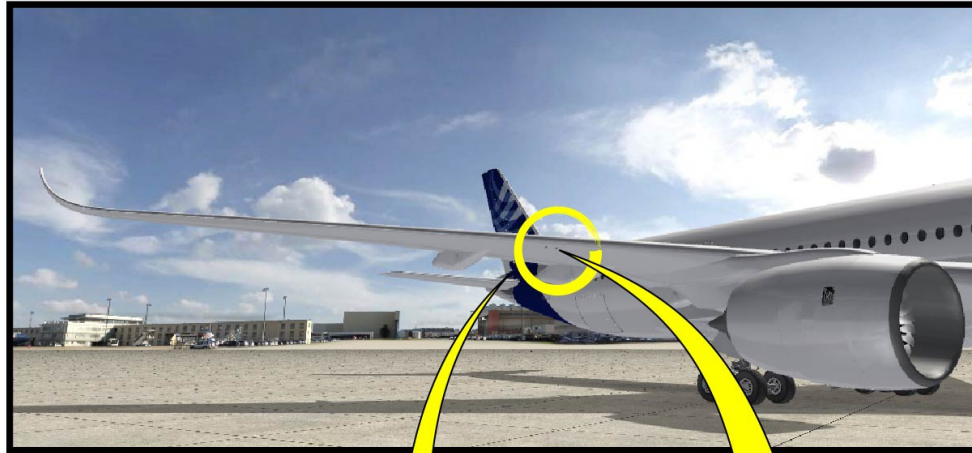

**RH SHOWN  
LH OPTIONALLY SIMILAR**

**REFUEL ISOLATION VALVE IS:**

- CONTROLLED BY THE SOLENOID  
OR THE MANUAL OVERRIDE BUTTON
- AND
- OPERATED BY FUEL PRESSURE

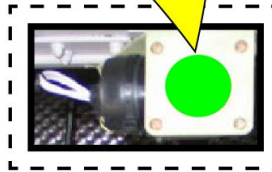

**"READY TO REFUEL" LIGHT**

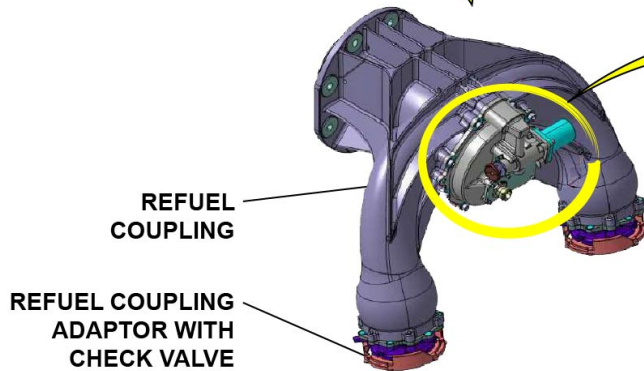

**REFUEL  
COUPLING**

**REFUEL COUPLING  
ADAPTOR WITH  
CHECK VALVE**

**MANUAL OVERRIDE BUTTON**

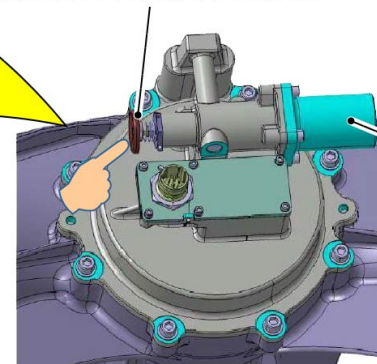

**SOLENOID**

**REFUEL ISOLATION VALVE**

**DESCRIPTION OF THE REFUEL/DEFUEL/TRANSFER SYSTEM COMPONENTS - REFUEL/DEFUEL COUPLINGS WITH REFUEL ISOLATION VALVES**

V1813401 - V01T0M0 - VM28D6REFUE3001

---

**REFUEL/DEFUEL/TRANSFER SYSTEM DESCRIPTION (2/3)****Description of the Refuel/Defuel/Transfer System Components  
(continued)**

possible to turn and lock the valve manually in the closed position with the mechanical visual position-indicator.

**Refuel/Defuel Gallery With Inlet Valves**

During refueling, when the refuel isolation valve is opened, the fuel goes from the external sources of fuel to the fuel tanks through a refuel gallery. The architecture of the refuel gallery lets you fill the fuel tanks at the same time. The refuel gallery is also used for transfers and defueling.

The fuel goes from the refuel gallery to the different fuel tanks (center and wings) through inlet valves. The inlet valves control fuel flow into and out of the fuel tanks. Each inlet valve is opened and closed by a Single-Power Supply Actuator (SPSA). Each SPSA has one motor and a position indicator switch that sends a feedback signal to give the actuator position. Each SPSA also includes a mechanical visual position-indicator for deactivation. If there is a failure, it is possible to turn and lock the valve manually in the closed position with the mechanical visual position-indicator.

In flight, you can operate the inlet valves manually to do a gravity transfer from the wing fuel tanks to the center fuel-tank, through the refuel/defuel gallery.

Surge relief valves are installed adjacent to each inlet valve to keep surge pressure in the limits when the valves close. They thus make sure that the pressure in the refuel system is kept in the limits.

**Defuel Valve**

In the basic configuration, there is one right-hand defuel valve. The defuel valve is closed or fully open. The defuel valve connects the engine feed gallery to the refuel gallery for pressure defuel and ground transfers. The refuel gallery then supplies a link to the refuel couplings for defueling on the ground. The defuel valve is controlled by the same single-power supply actuator as the refuel/defuel valves. It is

**INLET VALVES AND DEFUEL VALVE  
DRIVEN BY A SINGLE POWER  
SUPPLY ACTUATOR:**  
-> ONE MOTOR  
-> MECHANICAL VISUAL POSITION  
INDICATOR FOR DEACTIVATION

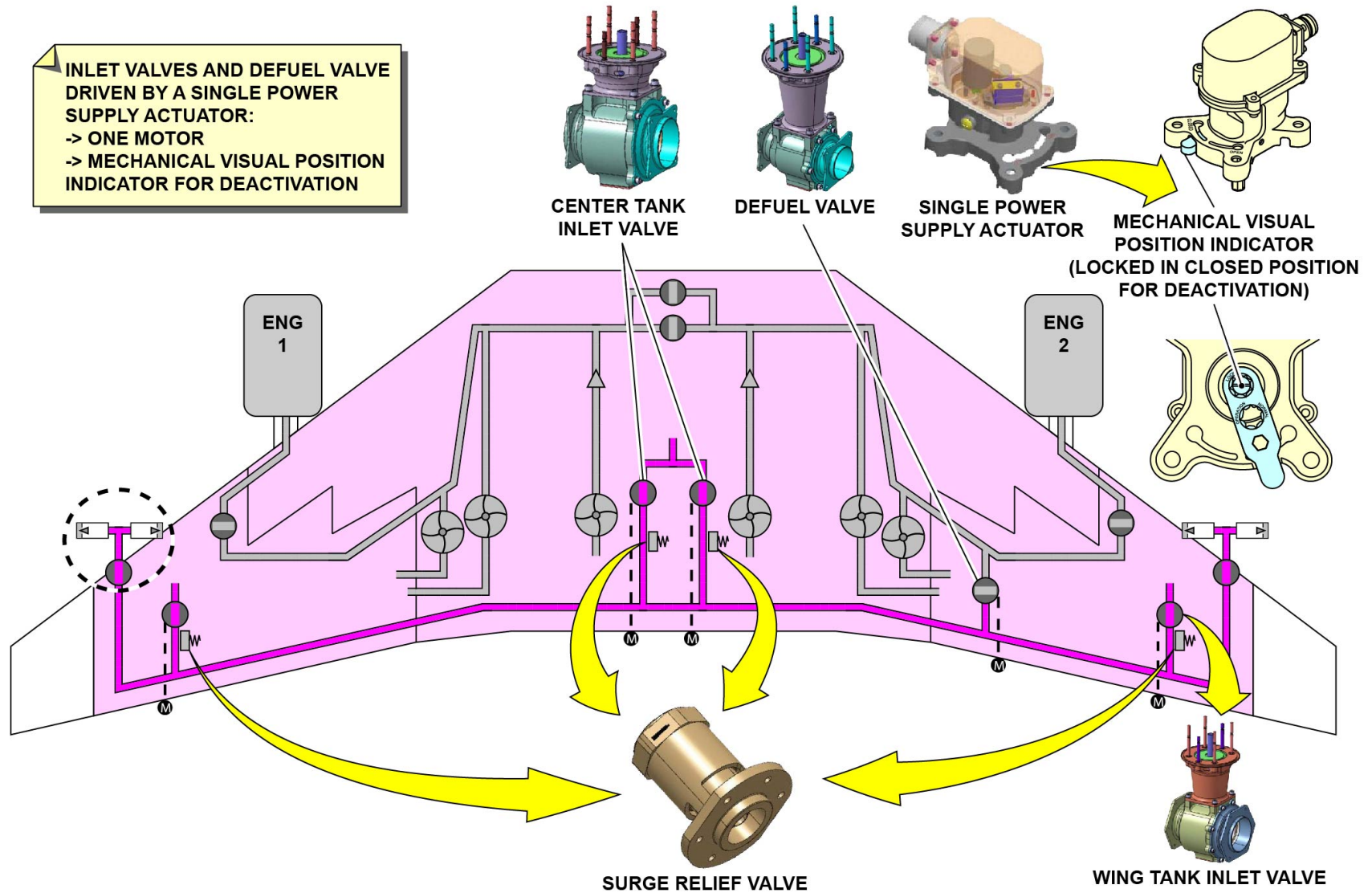

DESCRIPTION OF THE REFUEL/DEFUEL/TRANSFER SYSTEM COMPONENTS - REFUEL/DEFUEL GALLERY WITH INLET VALVES & DEFUEL VALVE

V1813401 - V01T0M0 - VM28D6REFUE3001

## REFUEL/DEFUEL/TRANSFER SYSTEM DESCRIPTION (2/3)

### Refuel/Defuel/Transfer System Control

The refuel, defuel and transfer procedure are:

- Manually started from the cockpit and/or the Integrated Refuel Panel (IRP)
- Manually stopped by the operator or automatically stopped by the FQMS.

When an operator does an automatic refuel procedure from the cockpit or the IRP, the actuators of the inlet valves (center fuel-tank and wing fuel tanks) and the refuel isolation valve(s) are fully controlled by the FQMS, through Solid State Power Controllers (SSPCs). The FQMS automatically closes the inlet valves when the necessary fuel quantity is supplied. The FQMS give protections to the automatic refueling if high level, vent and surge tank overflow or lateral imbalance occurs, or if one of the jettison system valves does not open (if the optional jettison is installed).

When an operator does a manual refuel procedure from the IRP, the actuators of the inlet valves (center fuel-tank and wing fuel tanks) and the refuel isolation valve(s) are controlled by the operator through the IRP but with protections from the FQMS, through the SSPCs. During manual refueling, the FQMS continues to give protections to the refueling if high level, vent and surge tank overflow occurs or if one of the jettison system valves does not open (if the optional jettison is installed).

When an operator does a pressure defuel procedure from the IRP and the cockpit, or a suction defuel procedure from the IRP, the actuators of the defuel valve and the refuel isolation valve(s) are controlled by the operator through the IRP but with protections from the FQMS, through the SSPCs. During defueling, the high level protection is inhibited to allow the defueling of an over-filled fuel tank. Pressure defuel is not available if the aircraft is electrically energized with batteries only.

When an operator does a ground transfer procedure from the IRP and the cockpit, the actuators of the inlet valves, the defuel valve and the refuel isolation valve(s) are controlled by the operator through the IRP and the

FQMS, with protections, through the SSPCs. The ground transfer automatically stops if vent and surge tank overflow occurs or if one of the jettison valves does not open. When the flight crew does a transfer from a wing fuel tank to the center fuel tank, the actuators of the inlet valves are controlled by the flight crew, through the SSPCs. There is no protection from the FQMS.

Some CRDCs interface between the refuel/defuel/transfer system components and the AFDX network, to give feedback to the FQMS.

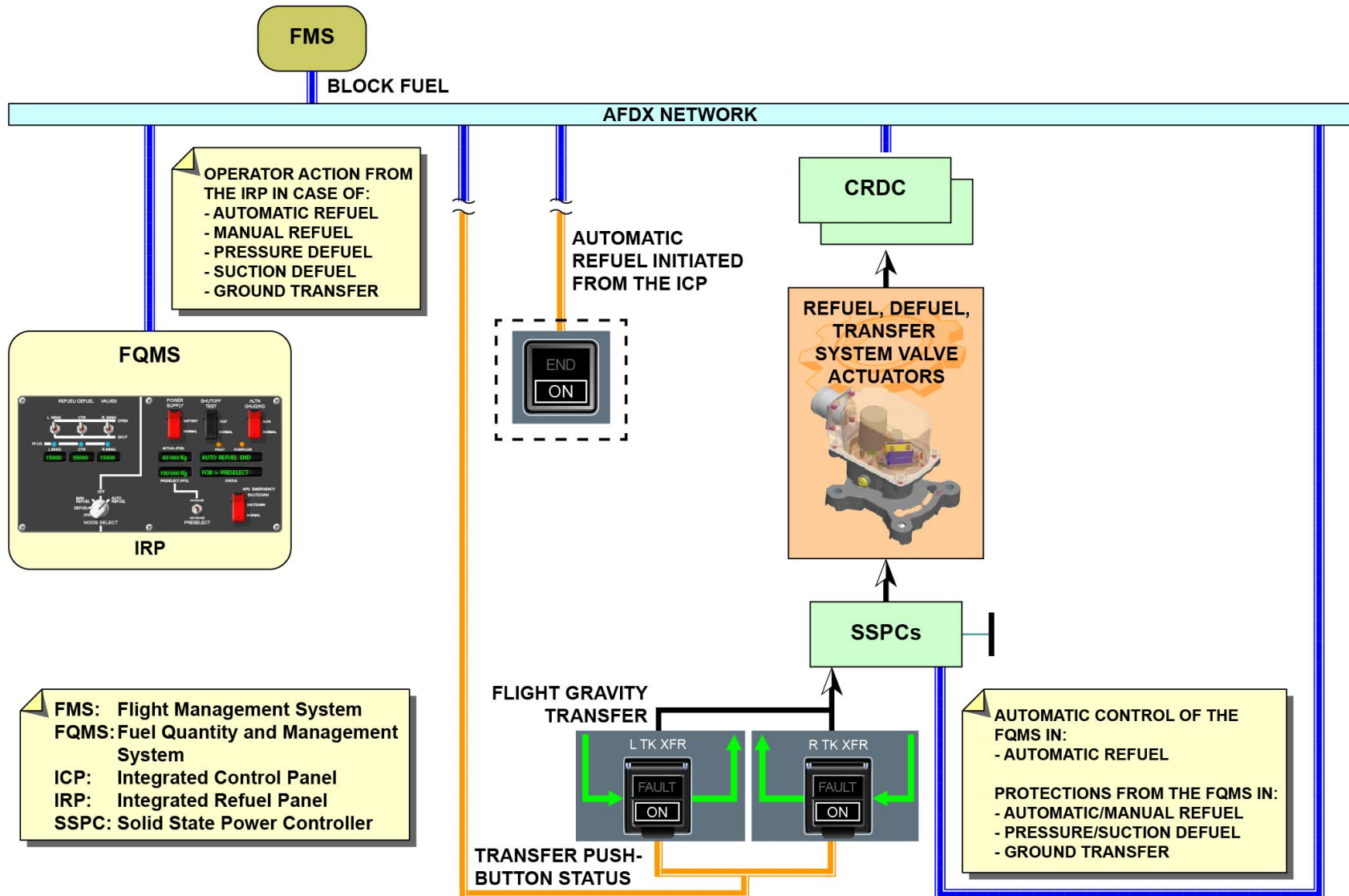

REFUEL/DEFUEL/TRANSFER SYSTEM CONTROL

V1813401 - V01T0M0 - VM28D6REFUE3001

## JETTISON SYSTEM DESCRIPTION (2/3)

### Jettison System Presentation

The function of the optional jettison system is to discharge fuel overboard, while the aircraft is in flight, to decrease the aircraft weight to less than the maximum landing weight. The jettison system has:

- Defuel/jettison valves (2) (each one operated by a single-power supply actuator),
- Center tank jettison valves (2) (each one operated by a single-power supply actuator),
- Jettison valves (2) (each one operated by a dual-power supply actuator),
- Jettison pipes (2) with anti-corona devices (2).

When the defuel/jettison valves open, they connect the wing fuel-tank pumps to the refuel gallery. The defuel/jettison valves are also used for pressure defueling. With a valve in the left wing fuel-tank and the right wing fuel-tank, operation of the crossfeed valves is not necessary for pressure defueling. When the center-tank jettison valves open, they connect the center-tank fuel pumps to the refuel gallery. When the jettison valves open, they discharge fuel from the refuel gallery to the atmosphere through an anti-corona discharge pipe on the wing. The position of the pipe makes sure that jettisoned fuel is not discharged on the aircraft structure.

An anti-corona device (a nozzle) is attached to the pipe end to prevent the possible ignition of fuel fumes because of electrical sparking (that can be caused by an electro-static discharge).

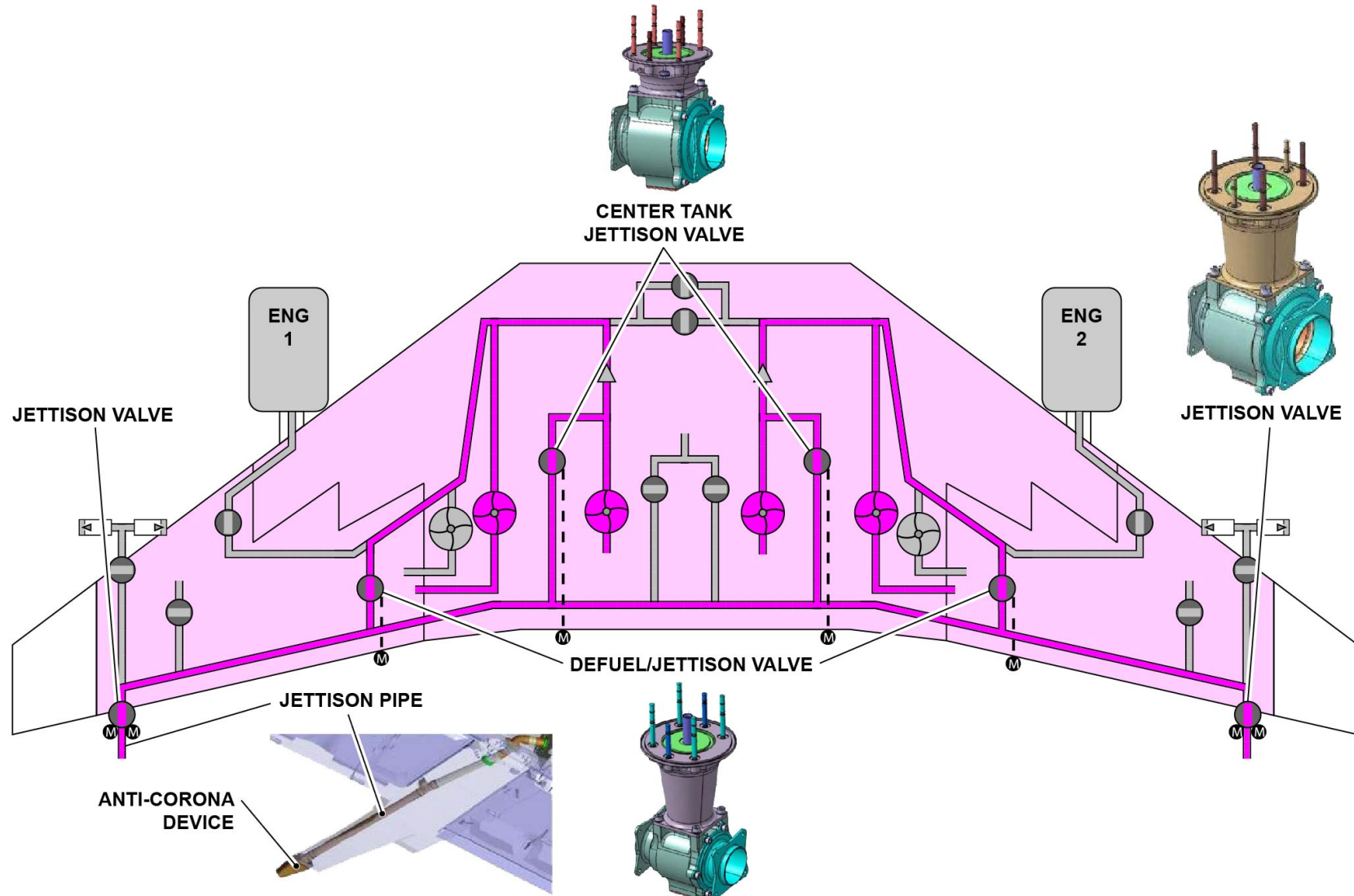

**JETTISON SYSTEM PRESENTATION**

V1813401 - V01T0M0 - VM28D7JETS3001

---

## JETTISON SYSTEM DESCRIPTION (2/3)

### Description of the Jettison System Components

#### Defuel/Jettison Valves and Center-Tank Jettison Valves

Each defuel/jettison valve and center-tank jettison valve is operated by a single-power supply actuator. Each single-power supply actuator has one motor and a position indicator switch that sends a feedback signal to give the actuator position. Each single-power supply actuator also includes a mechanical visual position-indicator for deactivation. If there is a failure, it is possible to manually turn and lock the valve in the closed position with the mechanical visual position-indicator of the actuator.

#### Jettison Valves

Each jettison valve is set to the open and closed positions by a dual-power supply actuator. Each dual-power supply actuator has two motors, each with an electrical power supply that operates independently, and a position indicator switch that sends a feedback signal to give the actuator position. Each dual-power supply actuator also includes a mechanical visual position-indicator. If there is a failure, it is possible to lock the valve in the closed position with a locking tool.



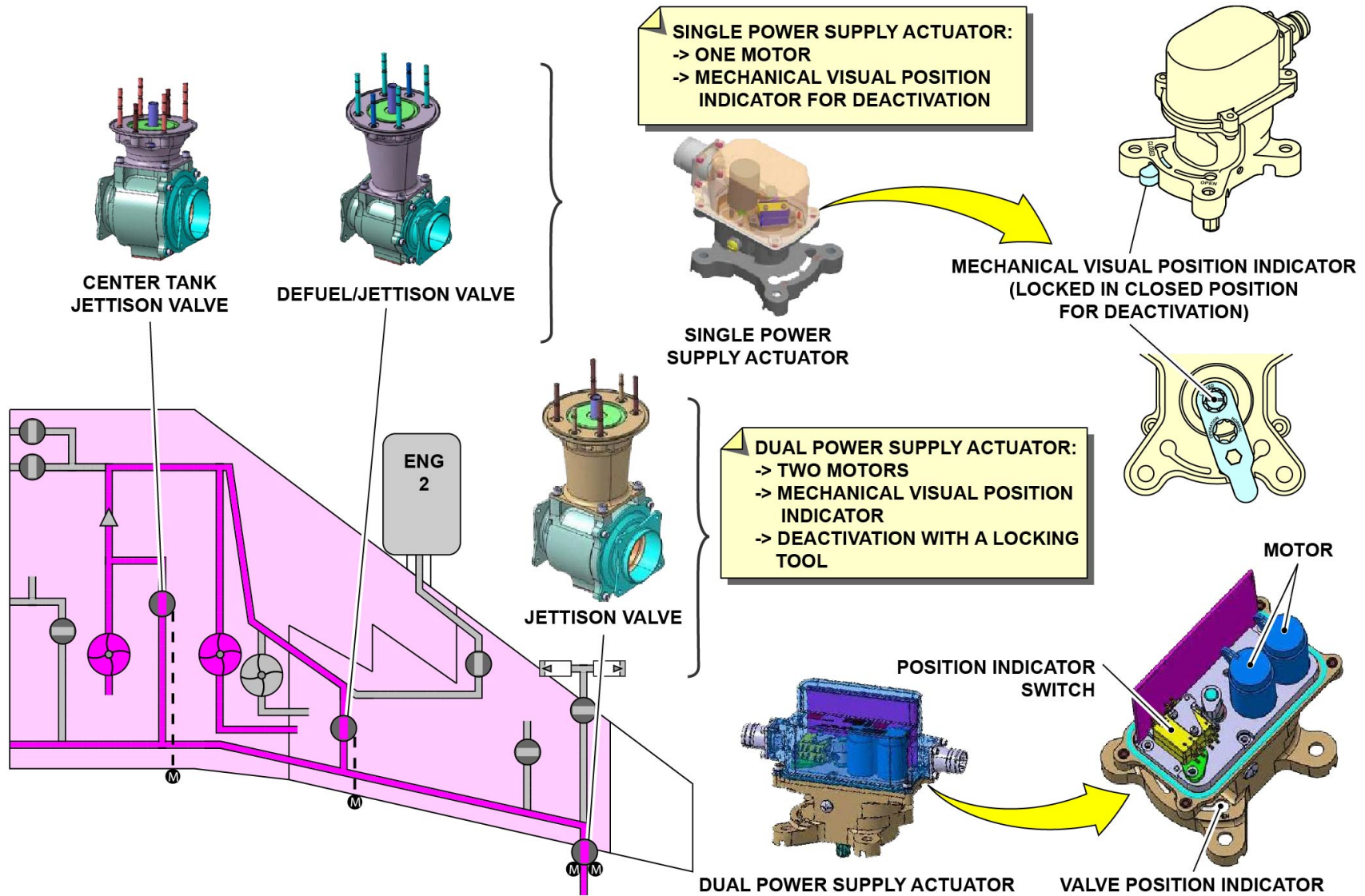

DESCRIPTION OF THE JETTISON SYSTEM COMPONENTS - DEFUEL/JETTISON VALVES AND CENTER-TANK JETTISONVALVES & JETTISON VALVES

V1813401 - V01T0M0 - VM28D7JETS3001

## JETTISON SYSTEM DESCRIPTION (2/3)

### **Jettison System Control Description**

The center-tank jettison valves, the defuel/jettison valves and the jettison valves are controlled with Solid State Power Controllers (SSPCs). The Integrated Control Panel (ICP) is used to start the jettison manually if the Fuel Quantity and Management System (FQMS) does not open the SSPCs. To manually start the jettison, push the ARM and ACTIVE pushbuttons. To manually stop the jettison from the ICP, release one of the two pushbuttons (ARM or ACTIVE). The FQMS automatically stops the jettison with the SSPCs if the fuel on board decreases to a minimum value or if the gross weight is the same as the jettison final gross-weight. Some CRDCs interface between the jettison system components and the AFDX network, to give feedback to the FQMS.

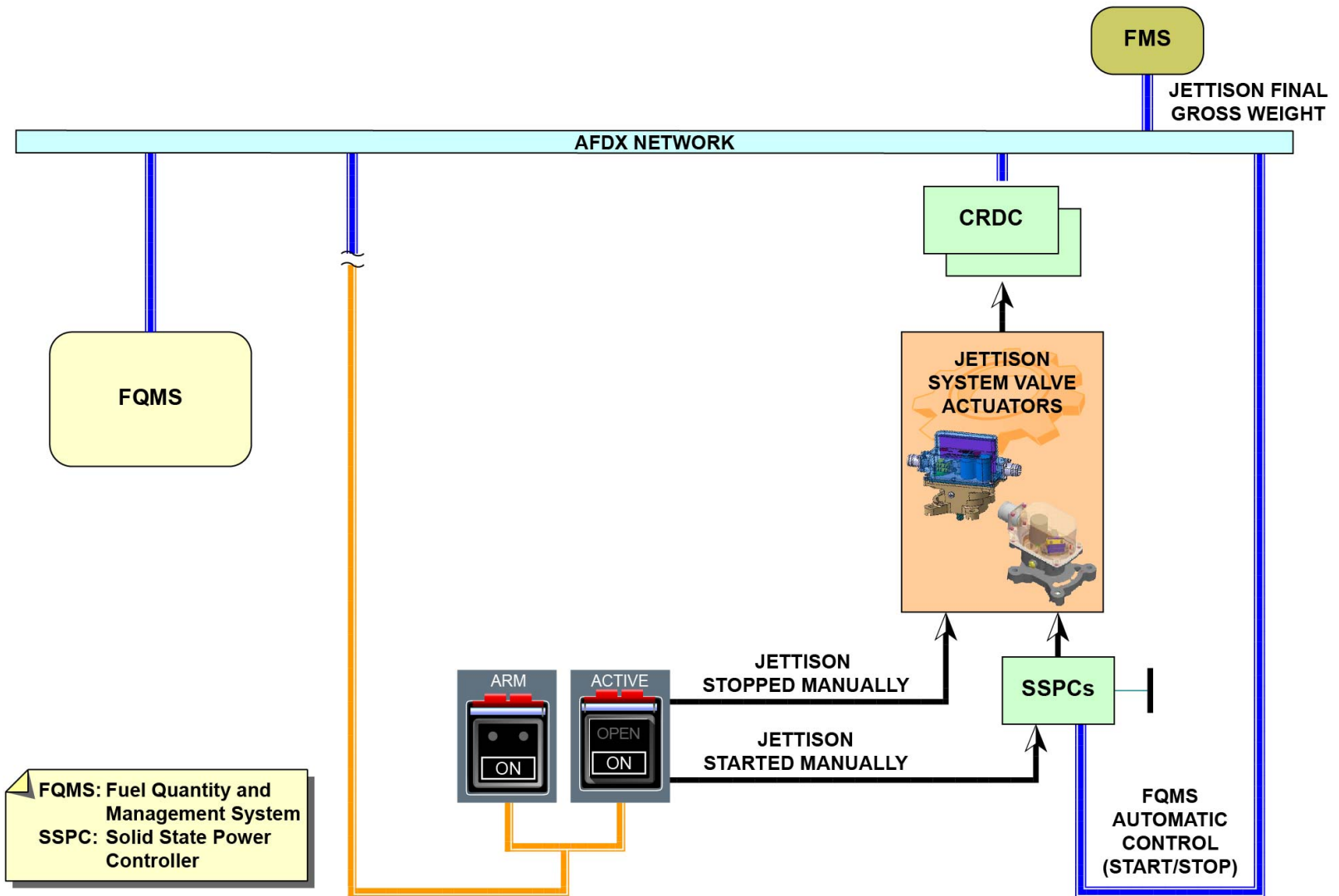

JETTISON SYSTEM CONTROL DESCRIPTION

V1813401 - V01T0M0 - VM28D7JETS3001

## FUEL SYSTEM CONTROL AND INDICATING (2/3)

### Fuel System - General (2)

The Fuel system controls are located on the FUEL panel, JETTISON (optional) panel, RESET panels (Overhead panel) and Integrated Refuel Panel (IRP). Fuel parameters are displayed on the IRP and FUEL SD page.

### Engine Feed System - CTR TK Pumps (2)

The left and right centre tank L(R) CTR TK pumps are controlled by their related P/B located on the FUEL panel.

In automatic mode, both CTR TK pumps operate when the Slats/Flaps are fully retracted (lever set to "0" position).

Nevertheless this automatic operation mode can be overridden by selecting the CTR TK FEED P/B to MAN, thus forcing both pumps to operate whatever the position of the Slats/Flaps lever is.

### Engine Feed System - CTR TK Pumps (3)

The L(R) CTR TK pumps are controlled by their related P/B located on the FUEL panel.

Each P/B has two integral captions that come on to display the following states:

- OFF (White) when the P/B is released out, to indicate the pump is not activated. The OFF light is extinguished when the P/B is pressed in to activate the pump.
- FAULT (Amber) to indicate the related pump is inoperative or in low pressure condition.

During take-off and landing phases with Slats/Flaps extended, or when the CTR TK is empty, the L&R CTR TK pumps are not running and the engines are fed by their related WING TK pump.

When the Slats/Flaps are fully retracted (lever set to "0" position) and there is fuel in CTR TK, both CTR TK pumps start to run, even if the WING TK pumps are running as well. The design of the pumps is such

that CTR TK pumps are more powerful than WING TK pumps, thus giving priority to CTR TK pumps to feed the engines when all pumps are running.

The CTR TK FEED P/B has two integral captions that come on to display the following states:

- FAULT (Amber) to indicate a failure of the automatic control of the CTR TK pumps,
- MAN (White) when the P/B is pressed-in to override the automatic control and to force the operation of both CTR TK pumps.

### Engine Feed System - Main and Standby Pumps (3)

The ENG1(2) MAIN & STBY pumps are controlled by their related P/B located on the FUEL panel.

Each P/B has 2 integral captions that come on to display the following states:

- OFF (White) when the P/B is released out, to indicate the pump is not activated. The OFF light is extinguished when the P/B is pressed in to activate the pump.
- FAULT (Amber) to indicate the related pump is inoperative or in low pressure condition.

In normal condition, only the MAIN pumps run. Each STBY pump starts automatically if the related MAIN pump is either faulty or selected off (LO PRESS condition detected by related pressure switch).

However on ground, during phase 1 or 2, the STBY pumps run automatically for 5 minutes after they are selected ON (for test) and then revert to stand-by mode.

### Engine Feed System - Low Pressure Shut-Off Valve (3)

The ENG1(2) Low Pressure Shut-Off Valves (LPSOV) are controlled OPEN or CLOSED by their related engine master switch.

Each LPSOV is commanded to close when releasing out the related ENG1(2) FIRE P/B.

When the aircraft is electrically de-powered, both LPSOV are commanded OPEN.

### **X-Feed (2)**

Each Crossfeed Valve can be manually open from the related X-FEED A(B) P/B on the Fuel panel. Each P/B has 2 integral captions to display the following states:

- ON (White) to indicate the Crossfeed pushbutton has been selected ON, otherwise it is extinguished,
- OPEN (Green) to indicate the related Crossfeed valve is open, otherwise it is extinguished.

### **APU Feed (2)**

APU fuel feeding indications are displayed on the FUEL SD page, on the LH side of engine 1 indication.

When the APU master switch is set to ON, the "APU" indication is displayed in white and the associated triangle is displayed in green. The fuel is fed to the APU via the APU Fuel Pump, the APU Isolation Valve and the APU Low Pressure Valve.

### **APU Feed (3)**

APU fuel feeding indications are displayed on the ECAM FUEL page on the LH side of engine 1 indication.

When the APU master switch is set to ON, the "APU" indication is written in white and the associated triangle is displayed in green.

The fuel is fed to the APU.

The fuel is taken from the engine 1 feed gallery and sent to the APU through the APU Isolation Valve and the APU Low Pressure (LP) Valve. If the pressure in the engine 1 feed gallery is too low, the APU Pump automatically starts to feed the APU.

The APU feeding is stopped (APU Isolation Valve and LP Valve closed, APU Pump stopped) when either of the following control is done:

- APU master switch set to OFF,

- APU FIRE P/B released,
- APU EMERGENCY SHUTDOWN P/B pressed.

When the APU Fuel-Vent P/B (located in the APU compartment) is pressed and held, the APU Isolation Valve and LP Valve are commanded OPEN and the APU pump starts (if the pressure is insufficient). The valves close and the pump stops immediately after the APU Fuel-Vent P/B is released.

### **Refuel from IRP (2)**

When the door of the IRP is open, the "REFUEL PNL DOOR OPEN" memo is displayed on ECAM.

The guarded SHUT OFF TEST P/B is used first to check the integrity of the IRP lights and displays (when pressed), and secondly to launch a valve shut-off test (when released). This test must be done prior to initiate any fuel movement from the IRP.

The IRP MODE SELECT rotary selector permits to select either of the following functions: Automatic Refuel, Manual Refuel, Defuel and Transfer.

The PRESELECT toggle switch permits to set the Preselected Fuel Quantity (PFQ) during an automatic refuel.

The REFUEL/DEFUEL VALVES toggle switches are used to control the refuel/defuel valves of the right (left) wing fuel tanks and of the centre fuel tanks, during a manual refuel, suction defuel or a fuel transfer.

The guarded POWER SUPPLY toggle switch permits to get electrical power supply to the IRP from the batteries when the A/C is not electrically powered.

The guarded ALTN GAUGING toggle switch (Ground Fuel Level Indication function switch) permits to get computation of the fuel tank levels and quantities (computed by the Tank Signal Processors of the Tank Wall Data Concentrators). The measurement accuracy is lower than the CPIOMs fuel application measurement accuracy.

The IRP displays the fuel quantities of each fuel tank, the ACTUAL (FOB) and PRESELECTED (PFQ) fuel quantities, and the STATUS of the system during ground operation.

The IRP also includes HI LVL (high level), OVERFLOW and FAULT indication lights.

### **Refuel from Cockpit (2)**

The cockpit Auto-Refuel function is an option that can be used to initiate an automatic refueling from the cockpit without any required action from the IRP.

The pre-selection of the required fuel quantity is done by entering the ZFW/ZFCG/BLOCK fuel figure on the "ACTIVE / FUEL & LOAD" page of the MFD.

The REFUEL P/B on the ICP has two integral captions that can be illuminated to display the following states:

- ON (white) to indicate the auto-refuel has been selected, otherwise it is extinguished,
- END (white) to indicate the auto-refuel has stopped (either complete or aborted), otherwise it is extinguished.

The "Ready-To-Refuel" light that is installed near the refuel/defuel couplings comes on when the pre-selected fuel quantity has been entered and the REFUEL P/B is selected ON. It gives the signal to the fuel truck operator that refueling can be started.

During a refueling initiated from the cockpit, the "CKPT REFUEL" message is shown on the IRP Status display.

### **Ground Transfer from IRP: L WING TK to CTR TK (2)**

The procedure to transfer some fuel from one tank to another is generally initiated as follows:

On cockpit FUEL panel:

- Select the pump(s) of the feeder tank to ON,

On IRP:

- Set the REFUEL/DEFUEL VALVES toggle switch of the receiver tank to OPEN,
- Set the MODE SELECT rotary selector to XFR,
- Monitor the fuel movements on IRP/SD display.

In the cockpit, the "GND XFR IN PROGRESS" green memo is shown on EWD.

### **Manual Transfer from cockpit : WING TK to CTR TK (2)**

When the L(R) XFR P/B is set to ON, a fuel transfer occurs from the related WING TK to the CTR TK through the related refuel/defuel valves. This fuel transfer is performed by gravity and without any protection from the FQMS.

### **OVERFLOW Detection (2)**

In case of OVERFLOW detection in the LH or RH wing surge tank during a refueling or during a ground fuel transfer, the following occurs:

- L(R) WING TK OVERFLOW warning is triggered on ECAM,
- OVFLW amber indication is shown on FUEL page below the affected tank,
- Refuel or ground transfer is immediately aborted by the FQMS,
- On IRP, the L(R) OVERFLOW message is shown on STATUS display and the OVERFLOW amber light comes on.

### **FQMS Failure (2)**

The failure of one FQMS side is identified by the FQMS 1(2) FAULT warning. This fault might result from the loss of one CPIOM but does not lead to any loss of fuel parameters indication on ECAM FUEL page. The failure of both FQMS sides is identified by the FQMS 1+2 FAULT warning. Such a failure leads to the complete loss of all FQMS sourced data including FQI and temperature indications which are replaced by "XX" on FUEL page (amber color) and on IRP (green color).

### **FQI Degraded Indications - FQI Failed Indications - GFLI (2)**

When the FQI accuracy status is NORMAL, the fuel quantities are displayed in GREEN to full resolution on ECAM and on IRP.

When the FQI accuracy status is DEGRADED, the affected fuel quantities are displayed on ECAM with 2 horizontal AMBER bars across the 2 last digits and on IRP with the 2 last digits replaced by GREEN dashes.

When the FQI accuracy status is FAILED, the affected fuel quantities are replaced by amber "XX" on FUEL page and green "XX" on IRP. As a consequence the FOB, GW and GWCG indications are also impacted. In case of loss of fuel quantity indication during ground operation, the use of the ALTN GAUGING toggle switch (Ground Fuel Level Indication function) permits to get computation of the fuel tank levels and quantities (computed by the Tank Signal Processors of the Tank Wall Data Concentrators). The measurement accuracy is lower than the CPIOMs fuel application measurement accuracy.

### **Wing Tank Low Level (3)**

When a low level condition is detected in a wing tank, the LO LVL amber indication is shown on the FUEL page in the affected tank.

During flight, the FUEL L(R) WING TK LO LVL additional warning is triggered on ECAM.

### **Jettison (Optional) (3)**

The optional Jettison System is activated from the FUEL JETTISON panel by means of the ARM and ACTIVE guarded P/B.

When the ARM P/B is pressed in, the ON legend comes on in white.

When the ACTIVE P/B is subsequently pressed in, the ON legend comes on in white, followed by the green OPEN indication that confirms the Jettison valves opening. The JETTISON IN PROGRESS green memo is displayed on ECAM.

On ECAM FUEL page, the following indications come on:

- Two JETTISON white indications,
- Two green arrows showing both Jettison valves opening,
- Four green arrows connecting to the Jettison valves indications and representing the CTR TK and WING TK DEFUEL/JETTISON valves opening.

The Jettison System operation is inhibited on ground by FQMS logic.

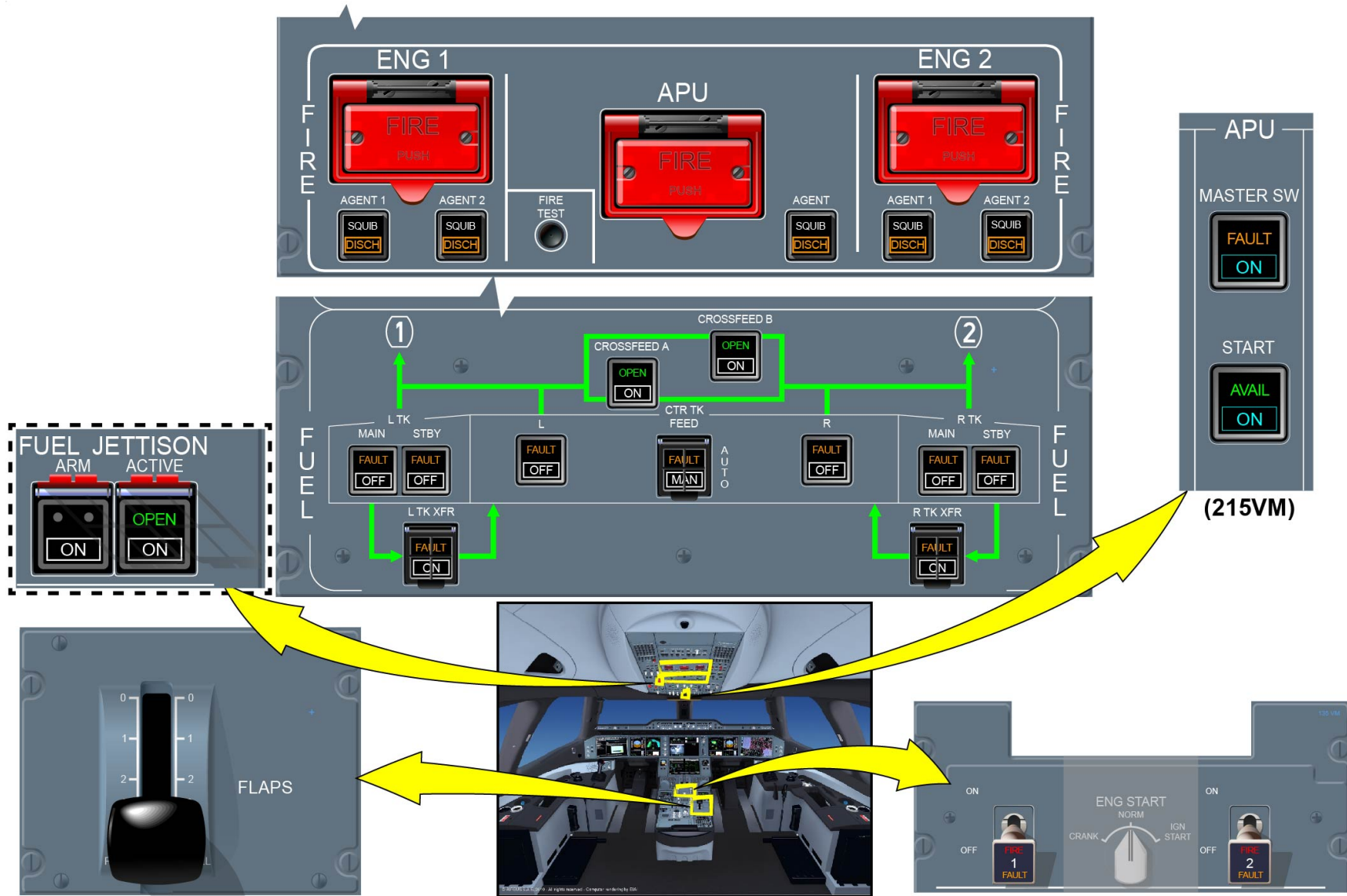

FUEL SYSTEM - GENERAL (2) ... JETTISON (OPTIONAL) (3)

V1813401 - V01T0M0 - VM2811000003001



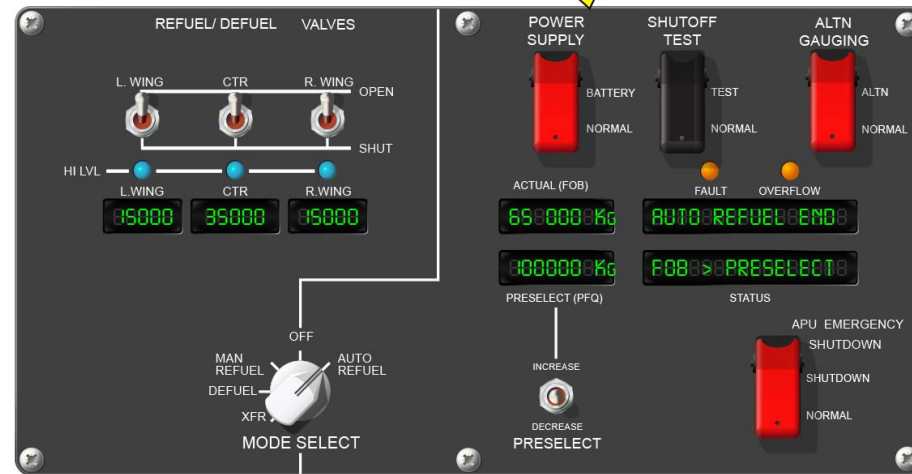

**INTEGRATED REFUEL PANEL (IRP)**

**FUEL SYSTEM - GENERAL (2) ... JETTISON (OPTIONAL) (3)**

V1813401 - V01T0M0 - VM281000003001

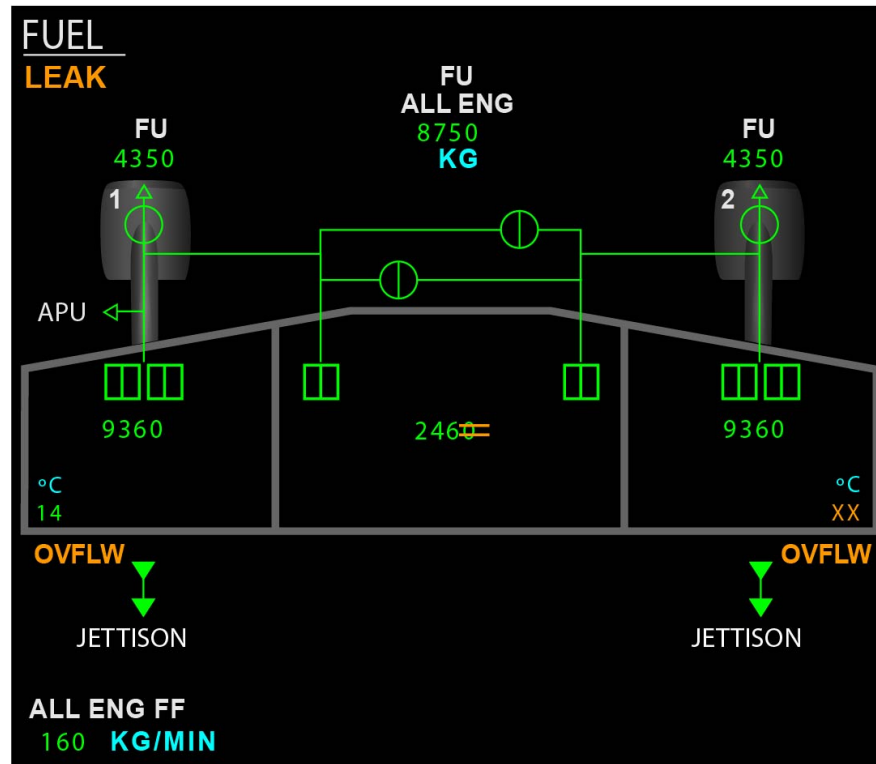

FUEL SD PAGE ABNORMAL INDICATIONS

TAT +10 °C	13: 28.00	GW 222600KG
SAT +10 °C		GWCG 33% <del>5</del>
		FOB 243 <del>400</del> KG

CDS PERMANENT DATA

FUEL SYSTEM - GENERAL (2) ... JETTISON (OPTIONAL) (3)

V1813401 - V01T0M0 - VM281000003001

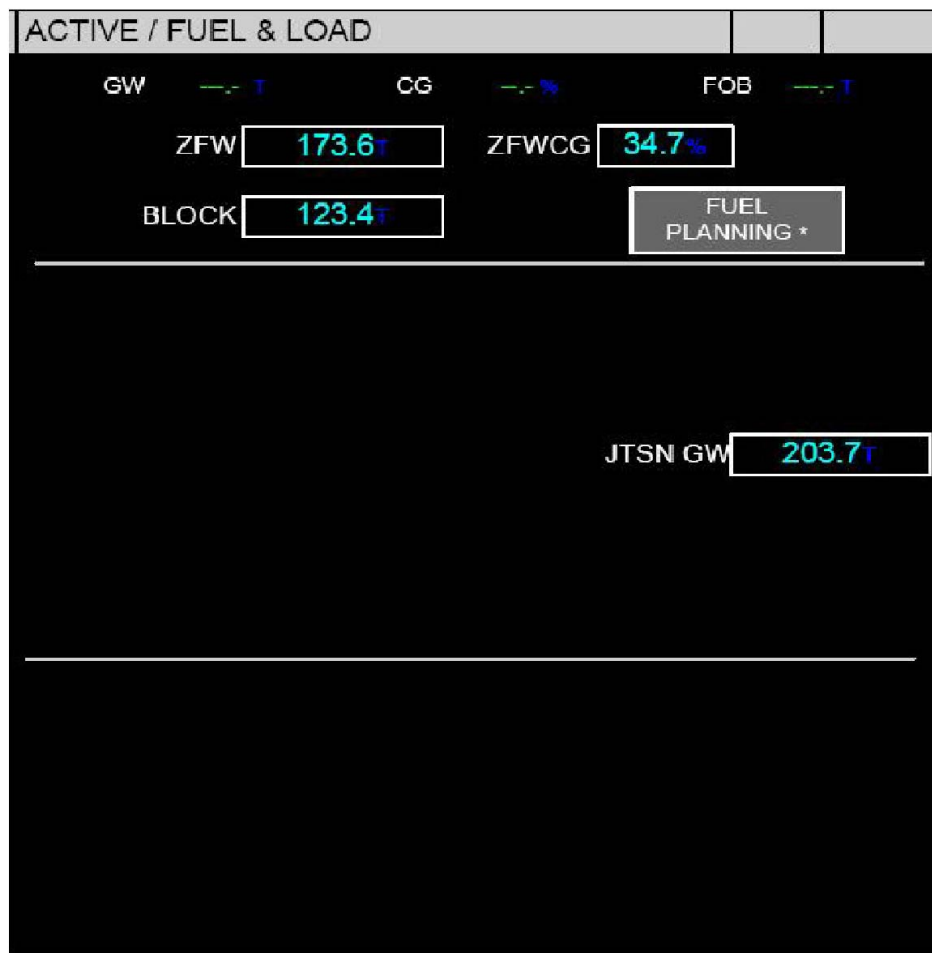
**FUEL & LOAD MFD PAGE**
**FUEL SYSTEM - GENERAL (2) ... JETTISON (OPTIONAL) (3)**

V1813401 - V01T0M0 - VM281000003001

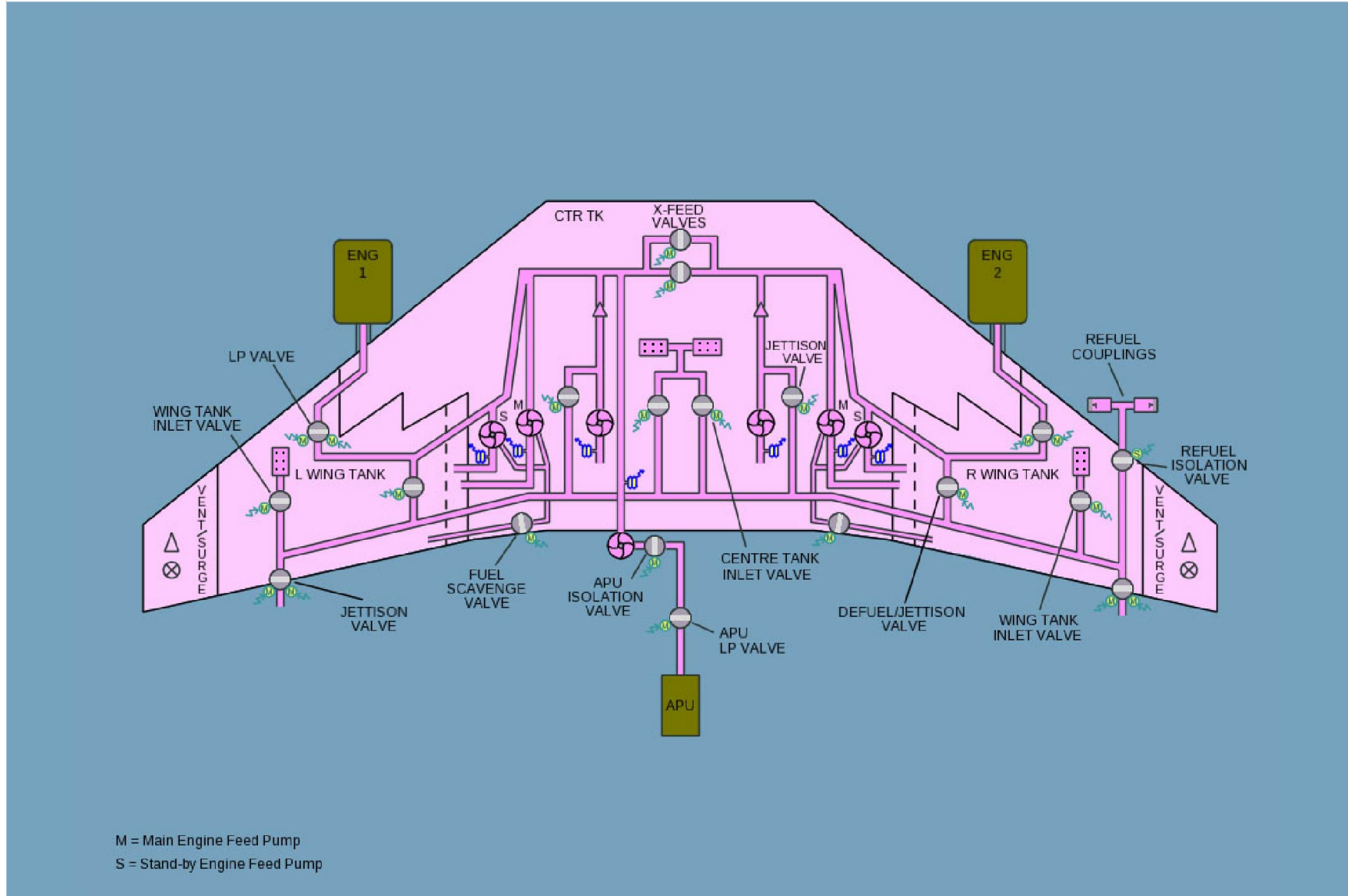

FUEL SYSTEM - GENERAL (2) ... JETTISON (OPTIONAL) (3)

V1813401 - V01T0M0 - VM2811000003001

This Page Intentionally Left Blank



**AIRBUS**  
AN EADS COMPANY

---

*AIRBUS S.A.S.  
31707 BLAGNAC cedex, FRANCE  
STM  
REFERENCE V1813401  
OCTOBER 2013  
PRINTED IN FRANCE  
AIRBUS S.A.S. 2013  
ALL RIGHTS RESERVED*

---

*AN EADS COMPANY*