

**A350**  
**TECHNICAL TRAINING MANUAL**  
**MAINTENANCE COURSE - T1+T2 - RR Trent XWB**  
**Flights Controls**





This document must be used for training purposes only

Under no circumstances should this document be used as a reference

It will not be updated.

All rights reserved

No part of this manual may be reproduced in any form,  
by photostat, microfilm, retrieval system, or any other means,  
without the prior written permission of AIRBUS S.A.S.



AIRBUS Environmental Recommendation

Please consider your environmental responsibility before printing this document.



**FLIGHTS CONTROLS**

Primary Flight Control System (PFCS) Description (2/3) . . . . .	2
PFCS Computers Group Description (3) . . . . .	12
PFCS Lateral Function Description (3) . . . . .	36
PFCS Vertical Function Description (3) . . . . .	52
Speed Brakes and Ground Spoilers Description (3) . . . . .	64
PFCS Backup System Description (3) . . . . .	76
Primary Flight Control System (PFCS) Control and Indicating (2/3) . . . . .	82
Primary Flight Control System (PFCS) Maintenance (2/3) . . . . .	94
High Lift System (HLS) Control Inputs Description (3) . . . . .	104
Slat and Droop Nose Description (3) . . . . .	108
Flaps Description (3) . . . . .	128
Aircraft Performance Optimization Description (3) . . . . .	158
Protection Laws Description (3) . . . . .	166
High Lift System (HLS) Control and Indicating (2/3) . . . . .	170
High Lift System (HLS) Maintenance (2/3) . . . . .	176

---

## PRIMARY FLIGHT CONTROL SYSTEM (PFCS) DESCRIPTION (2/3)

### PFCS

#### Introduction

The Primary Flight Control System (PFCS) includes all the control surfaces such as ailerons, spoilers, elevators, rudder and Trimmable Horizontal Stabilizer (THS) and their related computers, components and functions.

The PFCS controls the A/C in the roll, yaw and pitch axis from a pilot order (in manual mode) or from the Autopilot (AP) (in auto mode).

The PFCS also controls the lift on the wing which includes speed brake and ground spoiler functions.

The PFCS is classified by control axis. Control axis are divided into:

- Lateral functions (roll and yaw)
- Vertical function (pitch).

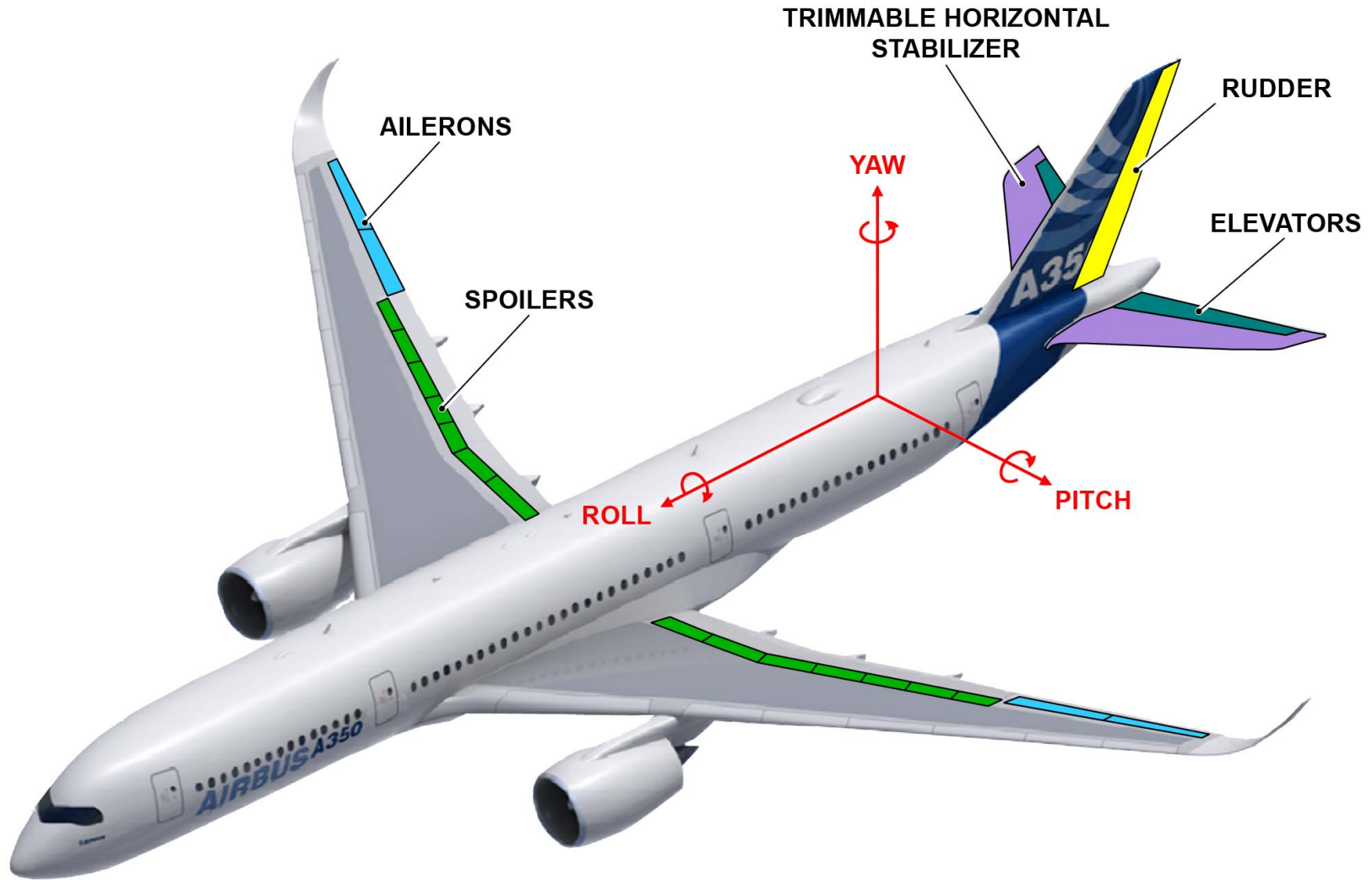

PFCS - INTRODUCTION

V1813401 - V01T0M0 - VM27D1PFCS03001

## PRIMARY FLIGHT CONTROL SYSTEM (PFCS) DESCRIPTION (2/3)

### PFCS (continued)

#### PFCS architecture

The PFCS has three blocks:

- Control inputs
- The computer group
- The actuation group.

The control inputs include the pilot inputs that follow:

- Side-sticks
- Rudder pedals
- Speed brake control-lever
- Pitch trim and rudder trim panel
- Computer P/BSWs.

The computer group includes different computers:

- PRIMary computer (PRIM)
- SECondary computer (SEC)
- Backup Control Module (BCM)
- Flight Control Data Concentrator (FCDC) applications
- Independent sensors (6 Rate Gyro and Accelerometer Units (RGAUs)).

The PRIM and SEC computers receive demand inputs from the pilot side-sticks or from the Flight Control Unit (FCU)/Flight Management Computer (FMC).

The A/C response and attitude is sent to the PRIMs and SECs by the Air Data/Inertial Reference Units (ADIRUs) and RGAUs.

Based on the demand inputs and A/C attitude, the computers send control surface orders to the actuation group.

The actuation group includes actuators and flight control surfaces for the ailerons, spoilers, THS, elevators and rudder.

Note that the communication between the PRIM and the SEC is done through ARINC 429 links but the communication between the computers and the actuation group and the RGAUs is done through standard MIL 1553 links.

Two different types of computers are used to control the ailerons, rudder, elevators, THS and spoilers.

- Three PRIMs
- Three SECs.

The module in charge of the backup system is also included in the computers group. It is called the BCM.

All types of computer can control the A/C.

Two FCDC applications do the data concentration integration.

The FCDC applications are hosted into the CPIOMs and are used as interface with the other systems (CDS, etc.).

A BCM is part of the backup control system and is used in case of total electrical failure or in case of permanent or transient failure of all the PRIMs and SECs.

A full digital architecture (MIL 1553) does the communication between the computers and the actuators to give protection to the A/C against lightning indirect effects. This architecture also saves weight through the reduction of the number of wires that are installed from the computers to the actuators.

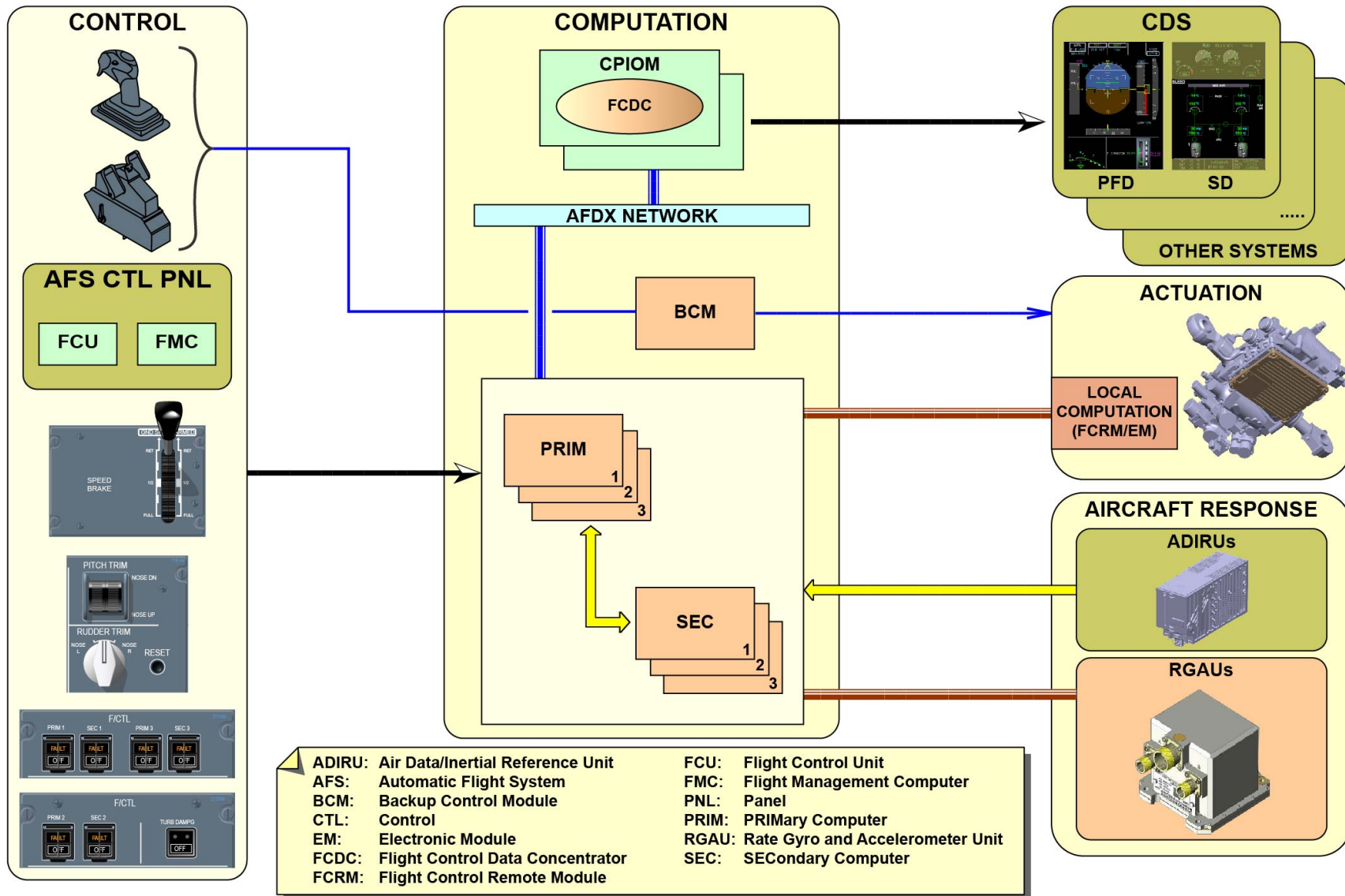

PFCS - PFCS ARCHITECTURE

V1813401 - V01T0M0 - VM27D1PFCS3001

---

**PRIMARY FLIGHT CONTROL SYSTEM (PFCS) DESCRIPTION (2/3)****PFCS (continued)****FBW philosophy**

In the Fly-by-wire (FBW) philosophy, each computer has a computation part.

The computation part receives the demand orders from the pilot in manual mode or from the Automatic Flight System (AFS). It also receives the A/C attitude and A/C response data from different units (ADIRUs, RGAUs, accelerometers).

Based on the demand inputs and A/C attitude, the computers elaborate an A/C objective and calculate the surface deflection command orders. The surface deflection command orders are sent to the execution part, located in the actuator Flight Control Remote Modules (FCRMs) or electronic modules. The actuators FCRM or electronic modules control their actuator to move the surface and receive feedback signals from their related actuator.

The FCRMs or electronic modules are installed on all the actuators for digital communication between computers and actuators (digital data into analog and discrete signals). They also change and process the analog signals from the actuator sensors into digital data to be sent to the computers.



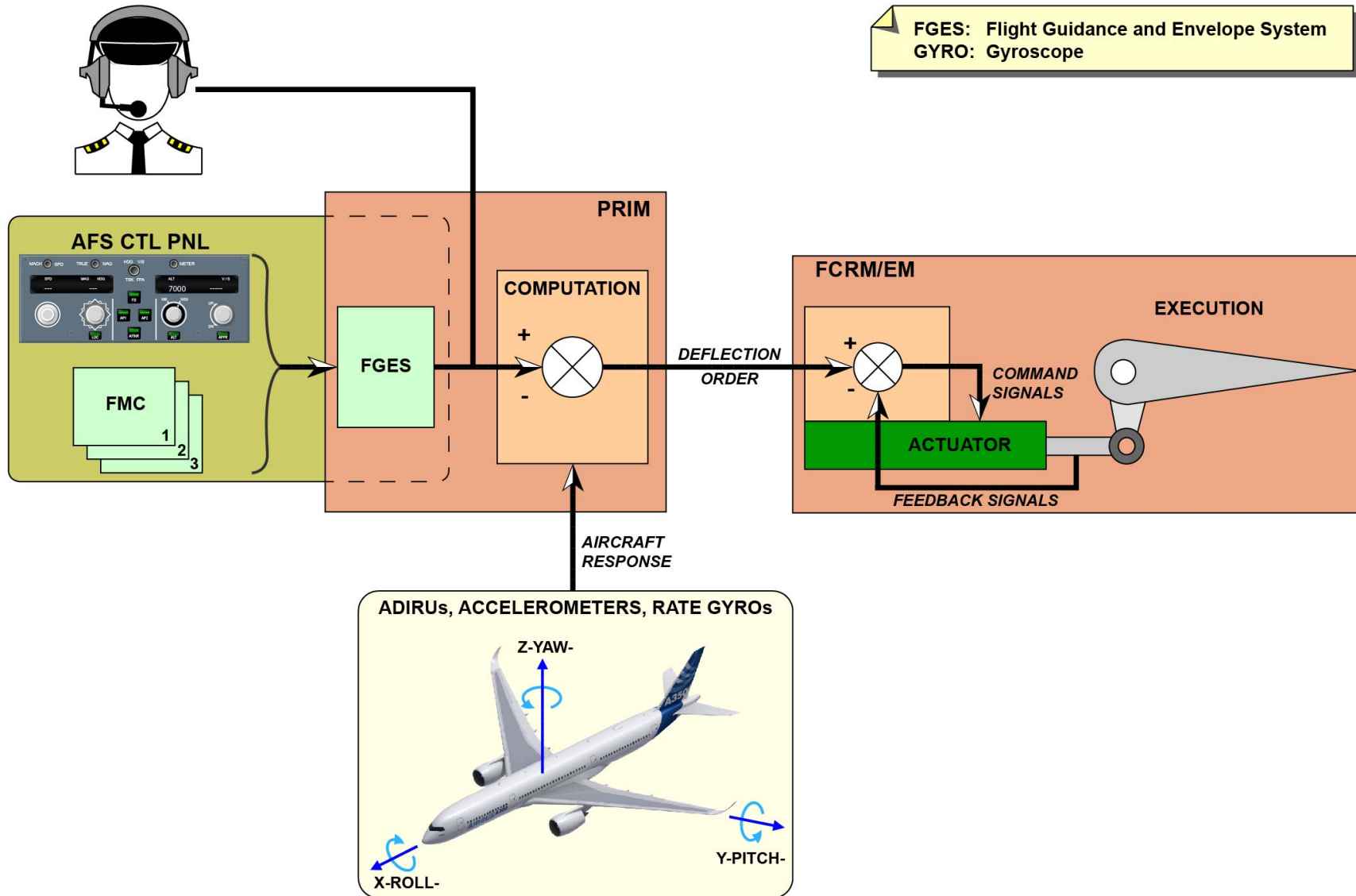

**FGES:** Flight Guidance and Envelope System  
**GYRO:** Gyroscope

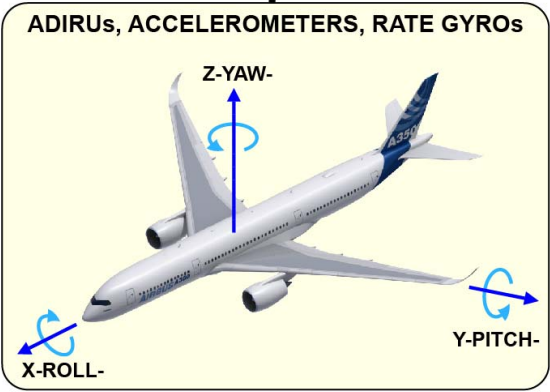

PFCS - FBW PHILOSOPHY

V1813401 - V01T0M0 - VM27D1PFCS3001

---

## PRIMARY FLIGHT CONTROL SYSTEM (PFCS) DESCRIPTION (2/3)

### PFCS (continued)

#### PFCS actuation

The A/C uses different types of actuators:

- Conventional servo-control actuators that use hydraulic power to move the surfaces.
- Electro-Hydrostatic Actuators (EHAs) that use electrical power to move the surfaces.
- Electrical Backup Hydraulic Actuators (EBHAs) that use hydraulic or electrical power to move the surfaces.

The EHAs and EBHAs are used to delete one hydraulic circuit thus to decrease the A/C weight.

Two electric motors are used to move the THS.

Each actuator can be controlled by two different computers, PRIMx or SECx. When one PRIM is not available, the actuators associated to it are controlled by the associated SEC, as a general rule for reconfiguration.

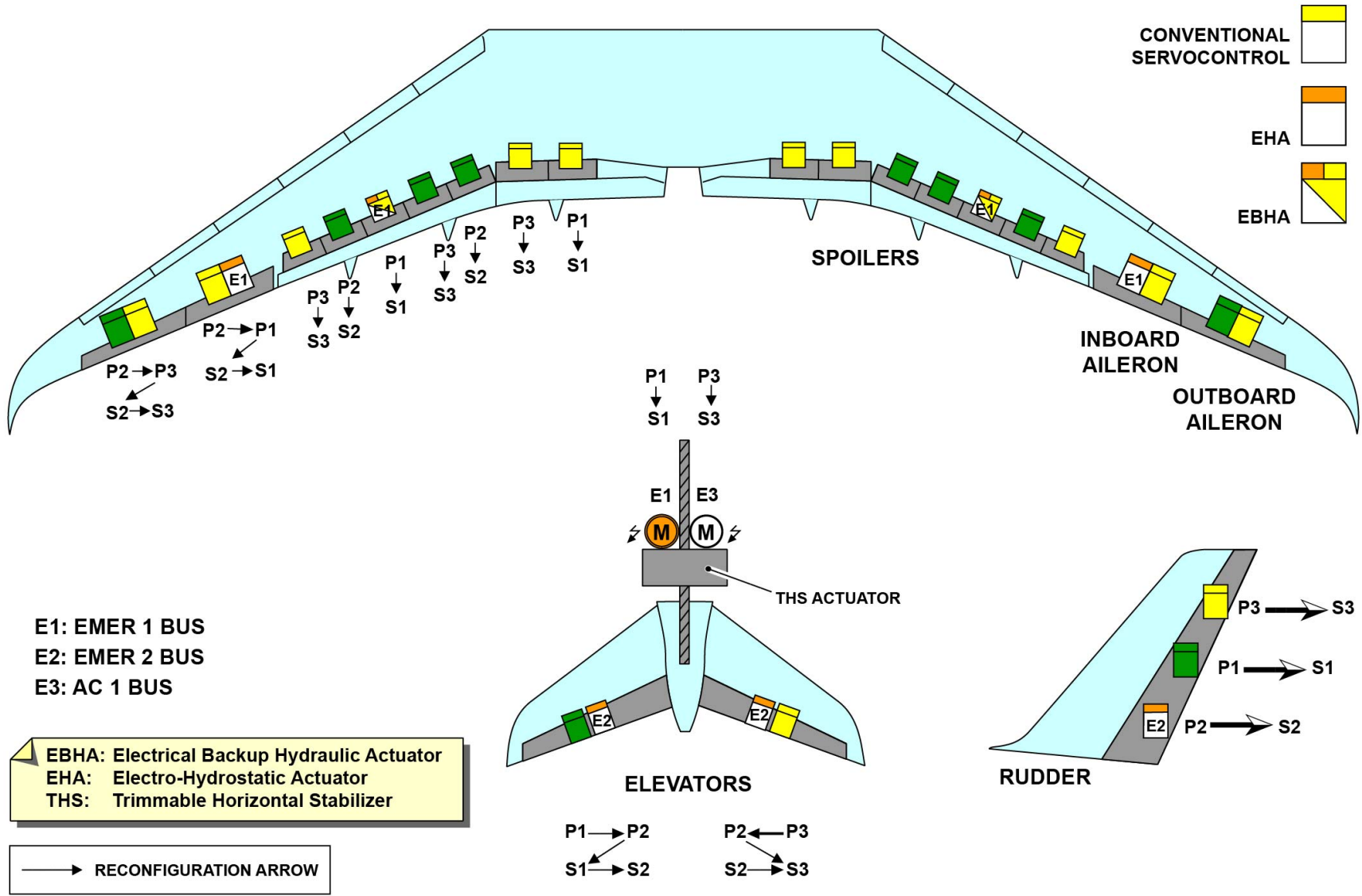

V1813401 - V01T0M0 - VM27D1PFCSD3001

---

**PRIMARY FLIGHT CONTROL SYSTEM (PFCS) DESCRIPTION (2/3)****PFCS (continued)****PFCS electrical backup system**

The electrical backup control system is active if there is a complete loss of electrical power or the P/BSW sets all the PRIMs and SECs to off. Its primary function is to control and stabilize the vertical and lateral axis of the A/C.

The BCM is used as a Flight Control Computer (FCC) and has its own power source, the Backup Power Supply (BPS). The BPS unit is an electric generator that changes yellow hydraulic power into electrical power.

When the BCM operates, it controls only with the servo-control actuators, the surfaces that follow:

- Left elevator
- Right elevator
- Rudder
- Left and right inboard ailerons.

Only the side-stick and pedal inputs are used when the BCM is active. The BCM can damp the Dutch roll. The BCM cannot control the THS actuator.

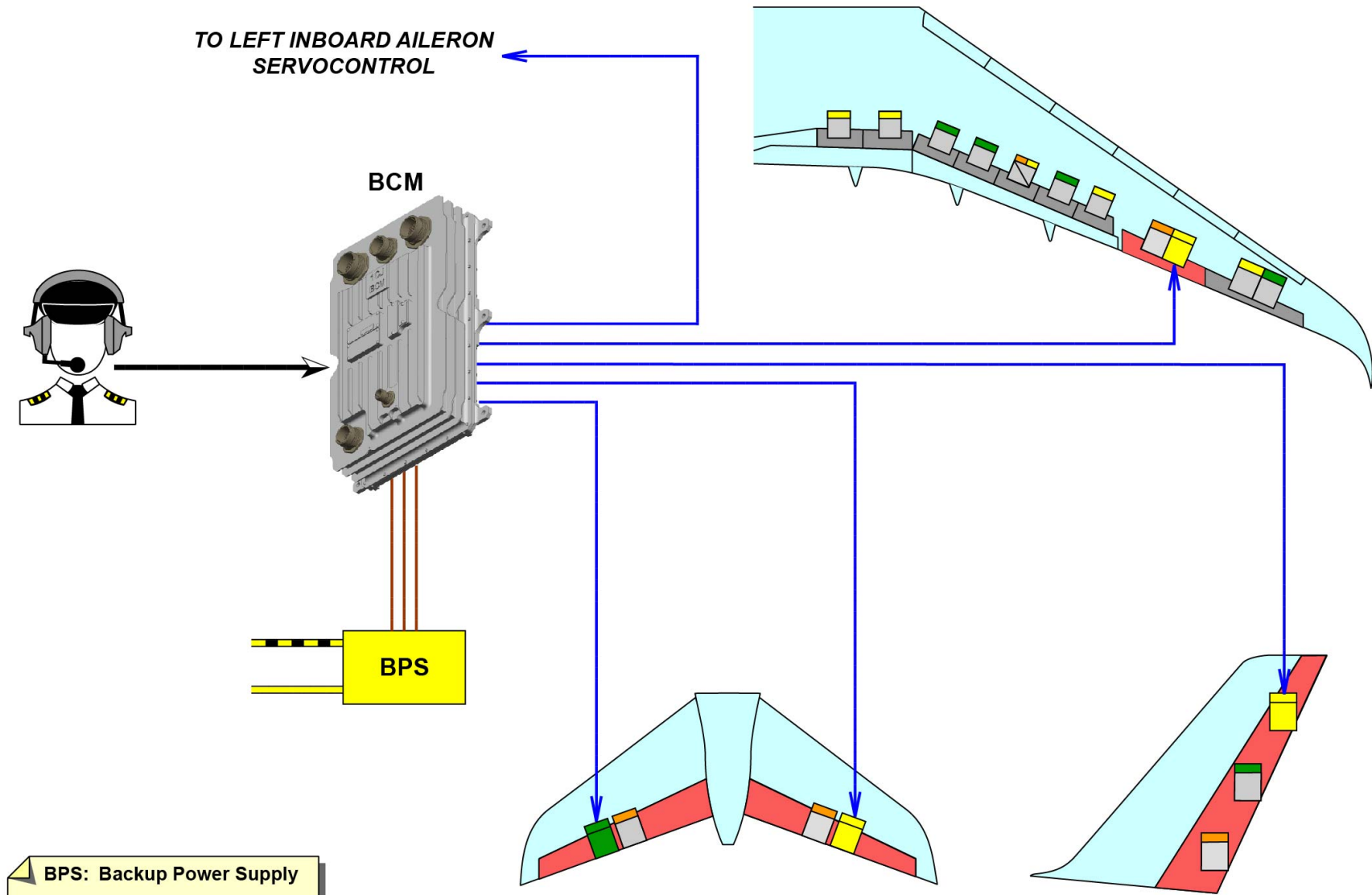

**PFCS - PFCS ELECTRICAL BACKUP SYSTEM**

V1813401 - V01T0M0 - VM27D1PFCS03001

---

## PFCS COMPUTERS GROUP DESCRIPTION (3)

### **Flight Control Laws**

The PRIMary computers (PRIMs) have different computation laws, divided into three levels:

- Normal
- Alternate
- Direct.

These levels are in relation to the availability and reliability of the A/C attitude and air data sensors.

The control laws give protection to keep the airplane attitude in the flight envelope with a security margin. The normal control law has the highest level of protections while the alternate law has less protections and the direct law has no protection.

The direct control law deflects the surfaces directly proportional to the side-stick or rudder pedals deflection. On ground, only the direct control laws are available.

The normal control laws supply some of the protections that follow:

- Load factor protection
- Angle Of Attack (AOA) protection
- High speed protection
- Bank angle protection
- Maximum rudder deflection protection.

SOME EXAMPLE OF NORMAL LAWS PROTECTIONS

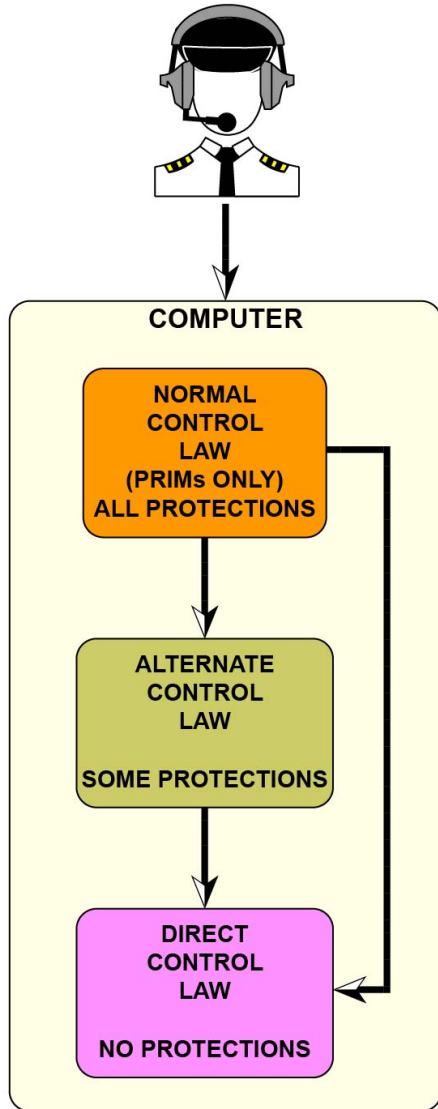
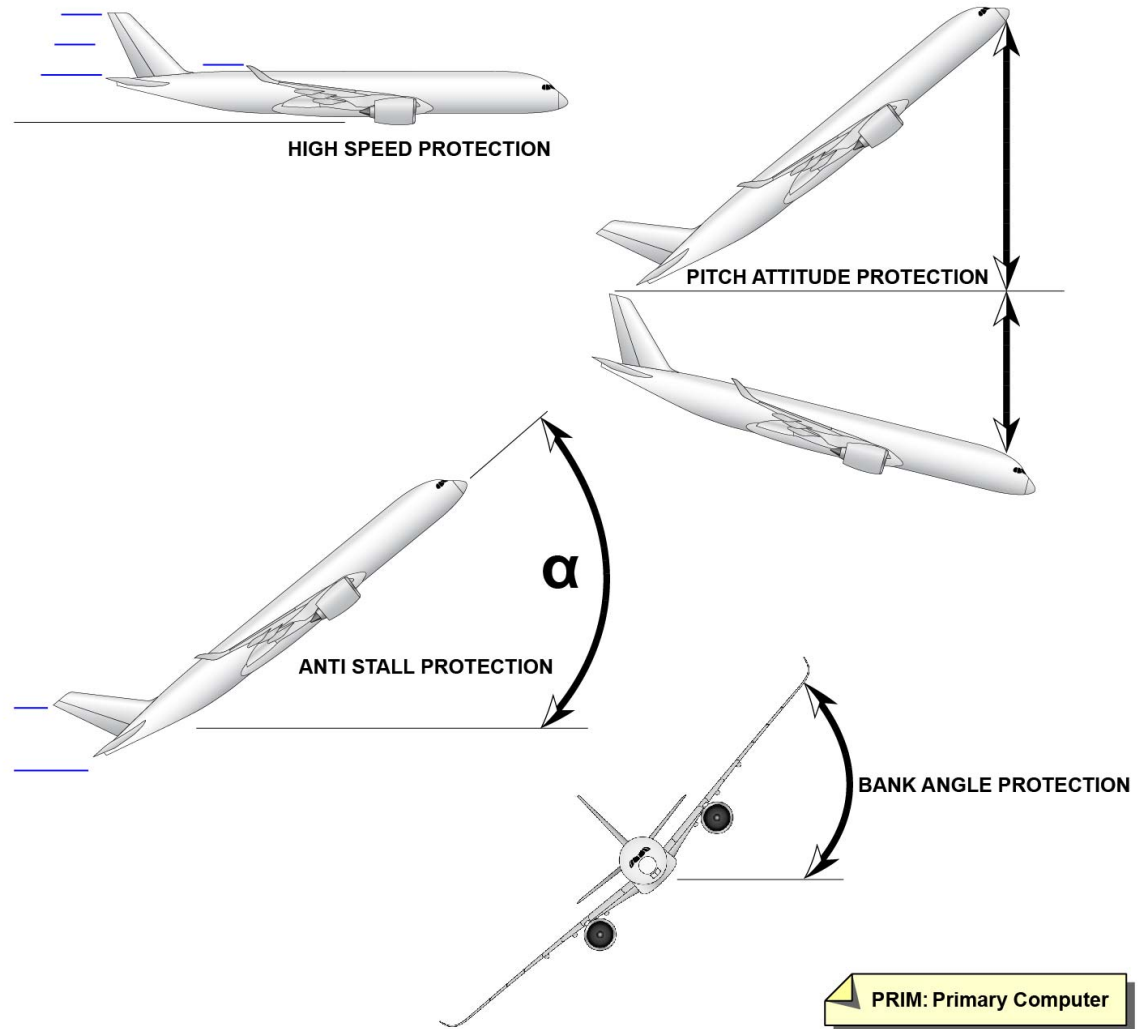

FLIGHT CONTROL LAWS

V1813401 - V01T0M0 - VM27D2PCOMP3001

## PFCS COMPUTERS GROUP DESCRIPTION (3)

### Computer Architecture

All the computers receive the demand orders from the pilot in manual mode or from the Flight Guidance and Envelope System (FGES) for the Autopilot (AP) mode. In nominal condition, only PRIM1 sends command orders to the others computers. It is the law master computer.

Based on the current A/C attitude, the master computer:

- Computes the demand orders and control laws into an A/C objective.
- Generates the surface deflection orders to all computers to get to the A/C objective.
- Compares the reached A/C attitude with the computed A/C objective.

The computers use all the received inputs: The demand orders from the pilots or the FGES and the A/C attitude/response inputs from equipments such as Air Data/Inertial Reference Units (ADIRUs), Rate Gyro and Accelerometer Units (RGAUs).

The law engagement logic in the PRIM uses two principles:

- The PRIM priority order as a master (which is PRIM1, PRIM2, PRIM3)
- The control-law level priority.

If the master computer does not receive all the necessary data, the master becomes the next computer with the higher law available. If PRIMX is lost, the associated SECX computer becomes active, and sends command orders to their associated actuators. In the A350 A/C, PRIMs and SECondary computers (SECs) work by pairs. Each actuator is commanded from only one pair of PRIM/SEC (see figure 2 for example).

If all three PRIMs are lost or if they cannot compute a control law, each SEC computes its own direct law, and sends its own orders to the related actuators. The A/C response is received from ADIRS only (see figure 3 for example).



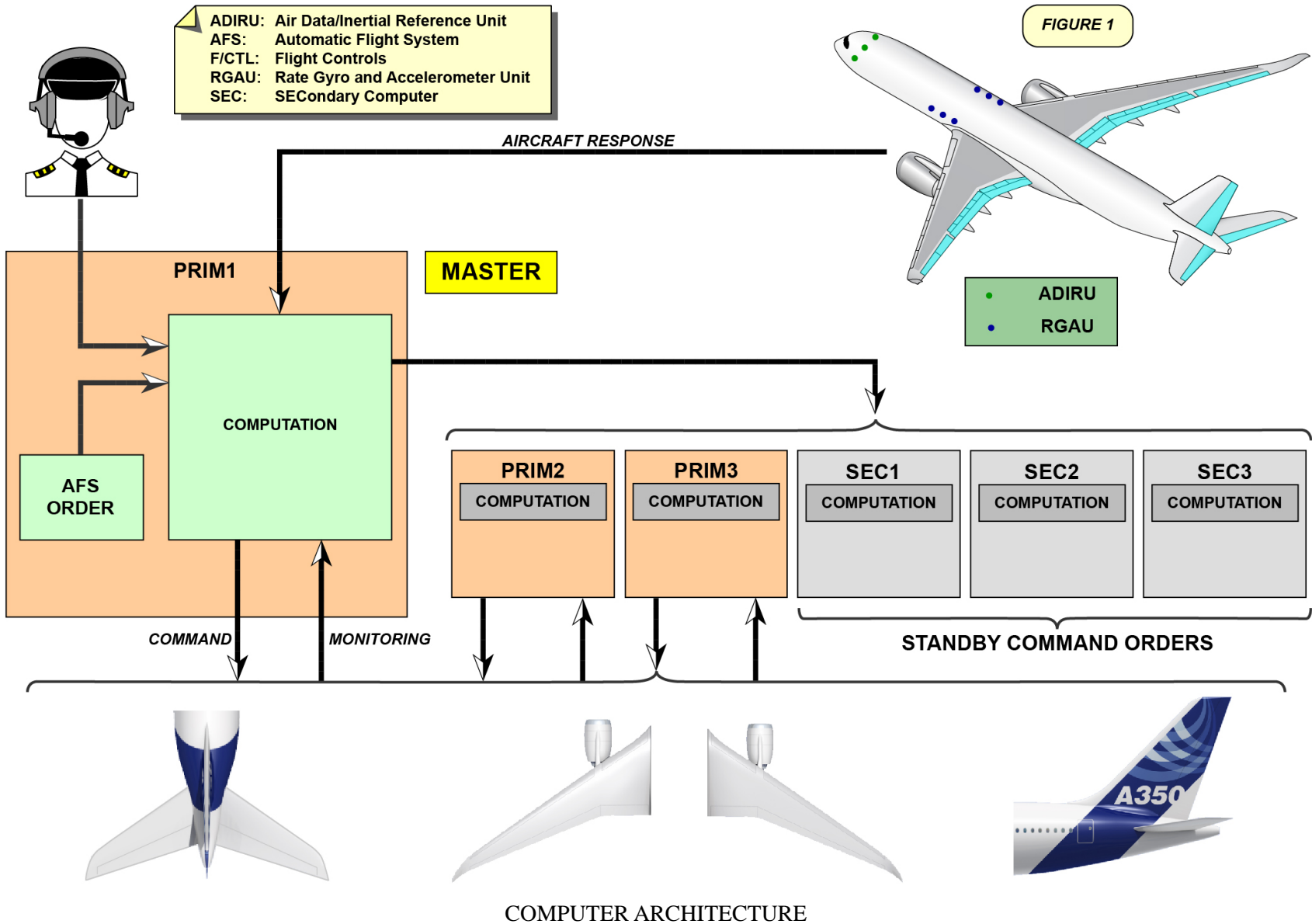

V1813401 - V01T0M0 - VM27D2PCOMP3001

FIGURE 2

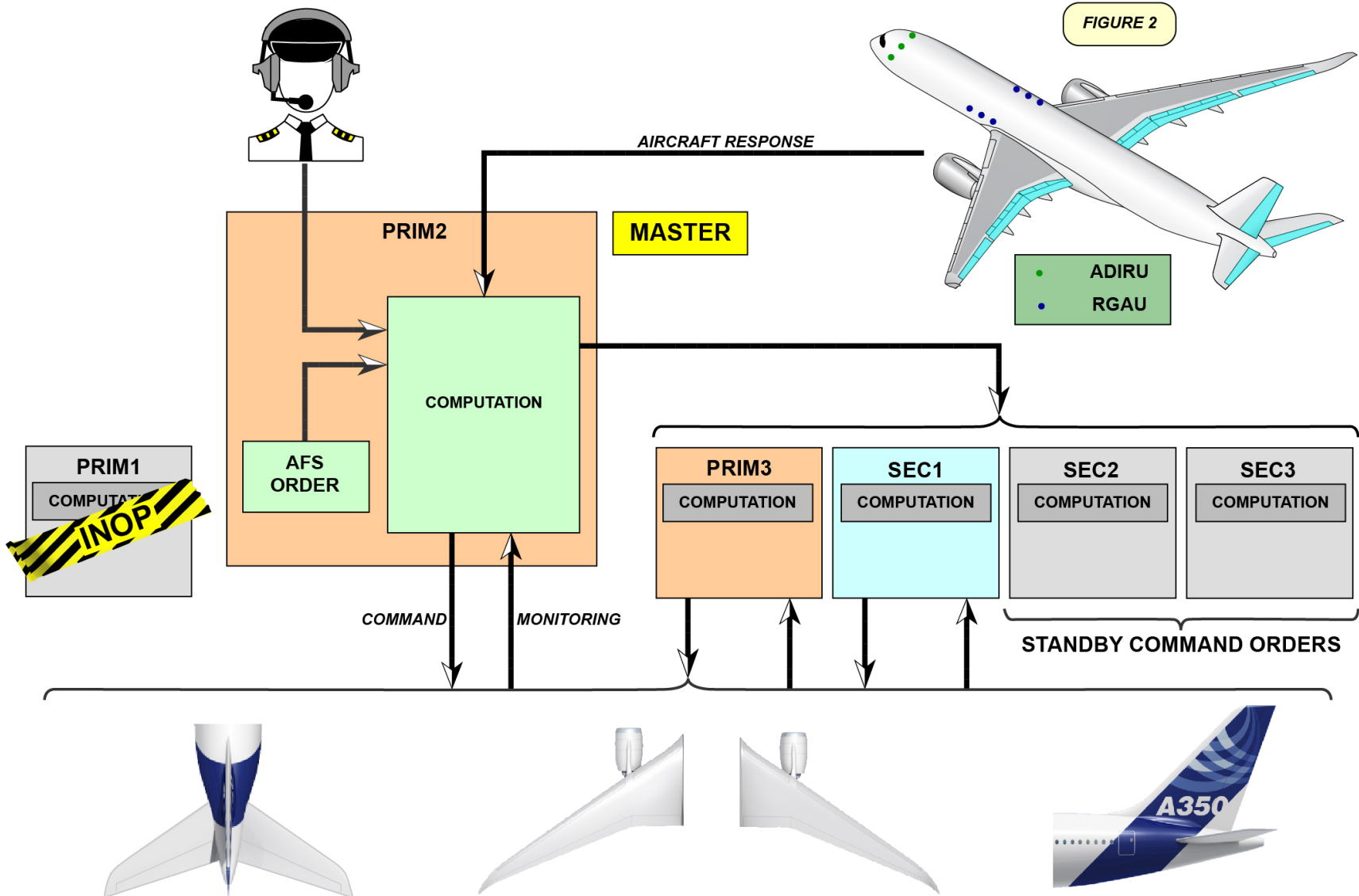

COMPUTER ARCHITECTURE

V1813401 - V01T0M0 - VM27D2PCOMP3001

FIGURE 3

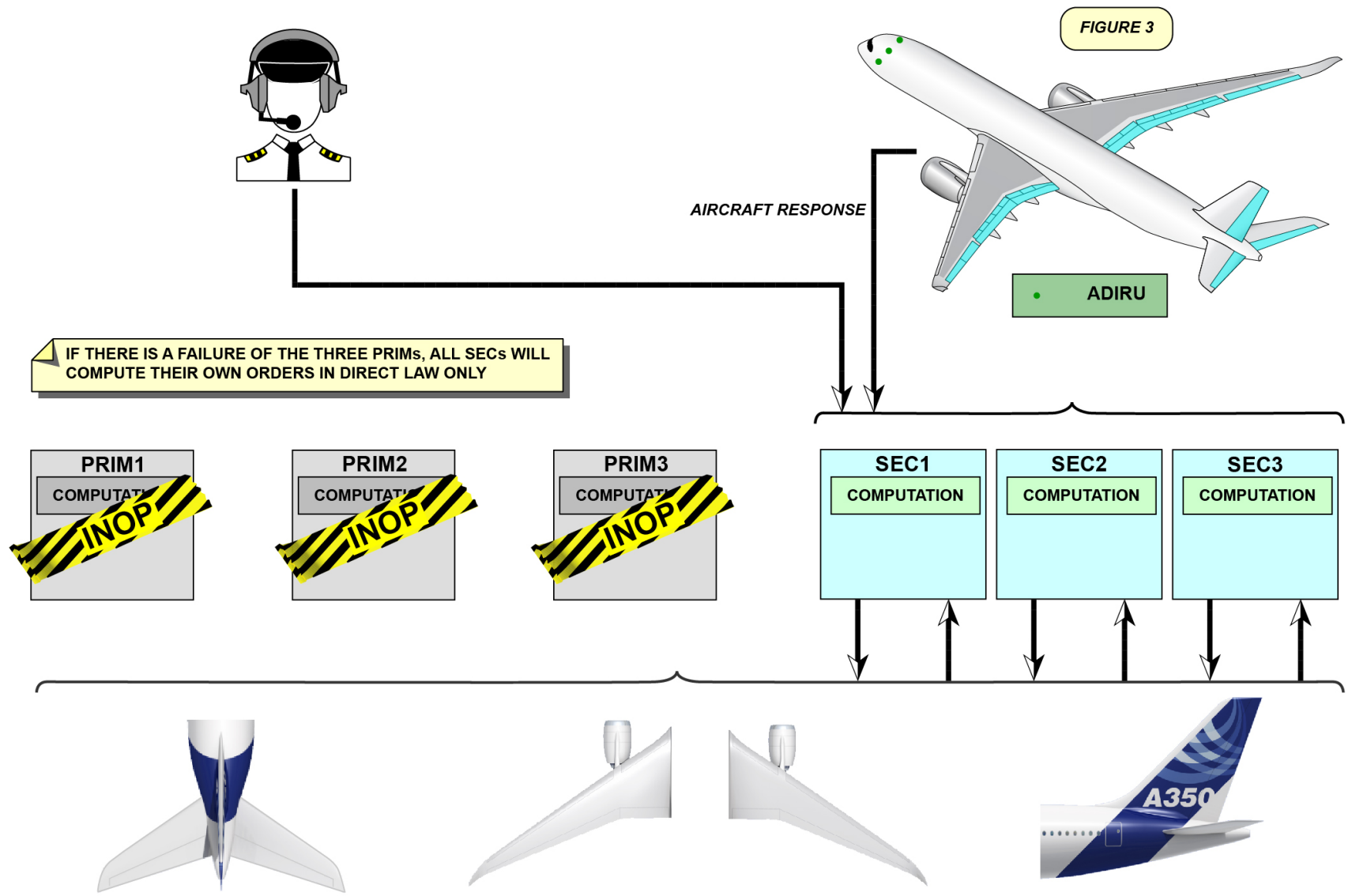

COMPUTER ARCHITECTURE

V1813401 - V01T0M0 - VM27D2PCOMP3001

## PFCS COMPUTERS GROUP DESCRIPTION (3)

### PRIMs, SECs and FCDCs

Each PRIM and SEC is one box with two independent units (A and B), physically and electrically segregated. Each unit does the Command (COM) and Monitor (MON) functions. Each unit is in charge of dedicated actuators that are segregated in three different zones: left wing, right wing and tail.

The COM functions are:

- To send the deflection command data to the actuators Flight Control Remote Modules (FCRMs) and electronic modules.
- To send the mode command orders (active/damping) to the actuators FCRM and electronic modules.

The MON functions are:

- To check that the deflection orders are correctly computed and performed
- To receive the data from the actuators FCRM and electronic modules (for system monitoring).

In each computer, units A and B permanently exchange data in order to avoid erroneous calculation and processing. When a discrepancy is detected between the COM and the MON functions or between the units, the computer is deactivated and considered as failed.

In addition to the COM and MON functions, all the PRIMs and SECs also do the functions that follow:

- Power supply of the actuators FCRM or electronic modules
- AFDX communication between the flight controls and the A/C systems.

Note: only the PRIMs do the FGES function

The FCDC (Flight Control Data Concentrator) do the following functions:

- Data concentration from PRIMs and SECs
- Generation of alerts to the FWS
- Generation of messages to the CMS
- Display of information on the PFD and creation of a flight control page on the SD.

Each FCDC application concentrates the system failures and sends the data to the FWS and CMS. In case of PRIM or SEC failure, the illumination of the PRIM or SEC P/BSW is done without the FCDC interface.

The FCDCs receive the surface position and side-sticks condition. The warnings will be triggered at take-off if the A/C configuration is unsafe for take-off:

- Spoilers not retracted
- Trimmable Horizontal Stabilizer (THS) not in take-off range
- Rudder trim not in take-off range
- Priority latched on one side-stick.

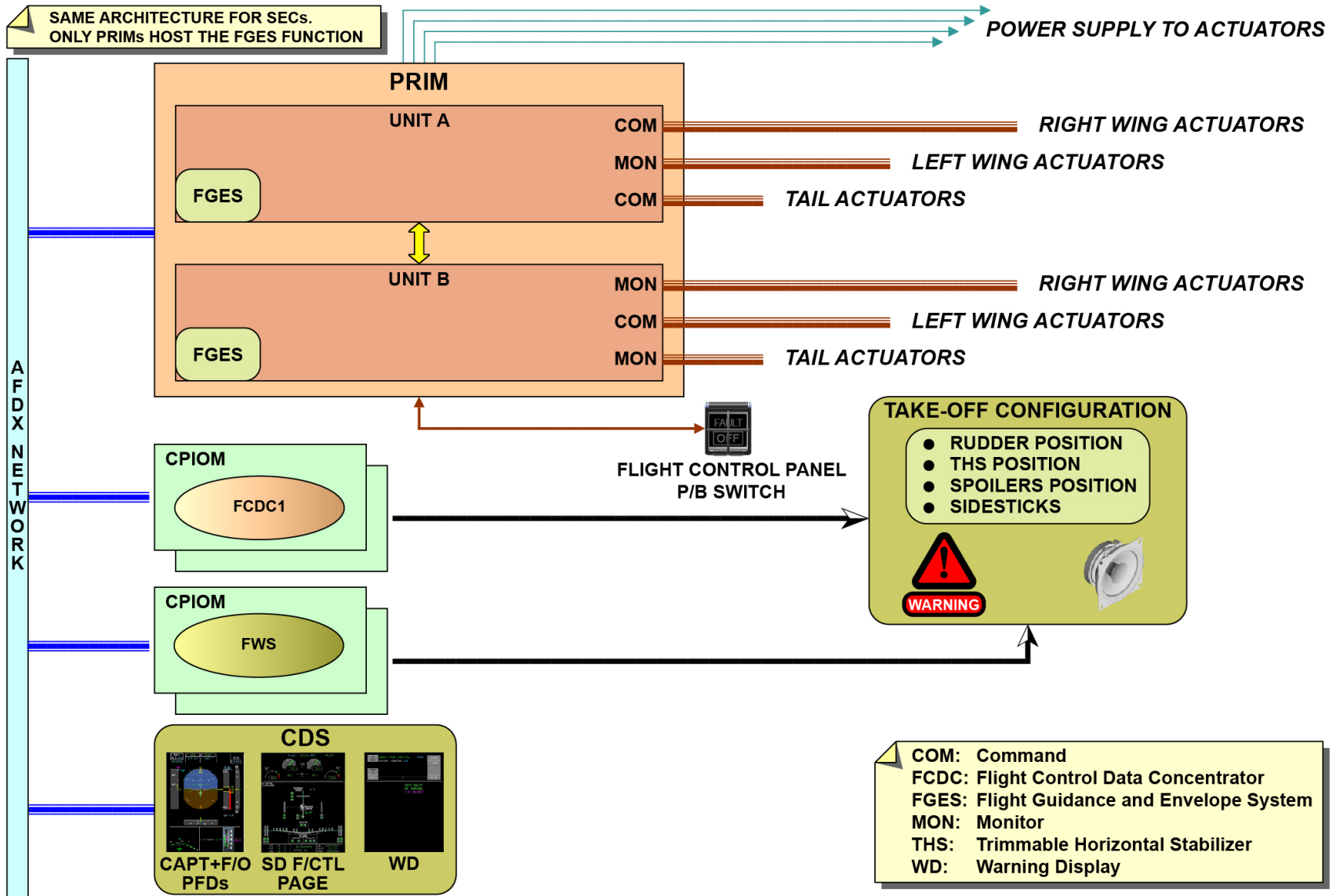

PRIMS, SECS AND FCDCS

V1813401 - V01T0M0 - VM27D2PCOMP3001

---

## PFCS COMPUTERS GROUP DESCRIPTION (3)

### General

The communication between each PRIM and SEC and the actuators is done through a digital network MIL 1553 and couplers.

The digital network is composed of COM and MON buses.

The computers send surface deflection orders to the actuators and monitor data received from actuators.

The COM digital data sent by the computers need to be converted into analog and discrete signals for the actuators. This is performed with remote terminals, called FCRM for the servo-control actuators or electronic module for the Electro-Hydrostatic Actuators (EHAs) and Electrical Backup Hydraulic Actuators (EBHAs).

Analog and discrete actuator signals are also converted by the FCRM (or electronic modules) into digital MON data for the computer.

A local servo-loop is done on each actuator with the FCRM (or the electronic modules). The FCRMs (or electronic modules) control the valves on actuators to achieve the surface deflection and use Transducers (XDRCs) to check the correct operation.

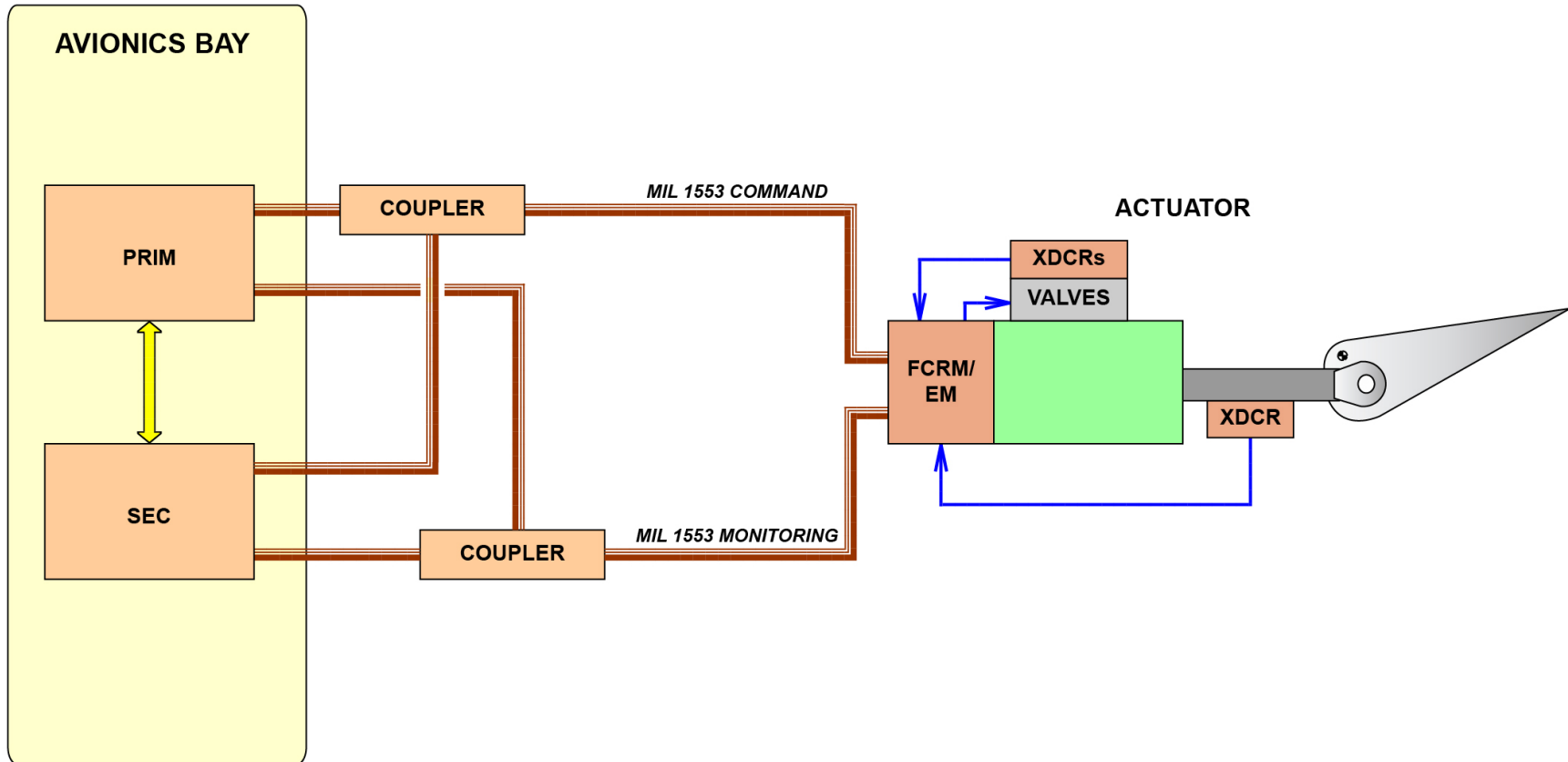

EM: Electronic Module  
 FCRM: Flight Control Remote Module  
 XDCR: Transducer

GENERAL

V1813401 - V01T0M0 - VM27D2PCOMP3001

---

## PFCS COMPUTERS GROUP DESCRIPTION (3)

### **Flight Control Architecture**

The architecture is based on redundancy and segregation.

There is the P1/S1 network, P2/S2 network and P3/S3 network.

Each network uses dedicated and independent computers, couplers, buses and actuators.

In each network there are three groups of actuators, one per A/C section:

- Left wing actuators group
- Right wing actuators group
- Tail actuators group.



3 SEGREGATED NETWORKS: EACH NETWORK HAS DEDICATED  
 - COMPUTERS  
 - COUPLERS  
 - BUSES  
 - ACTUATORS

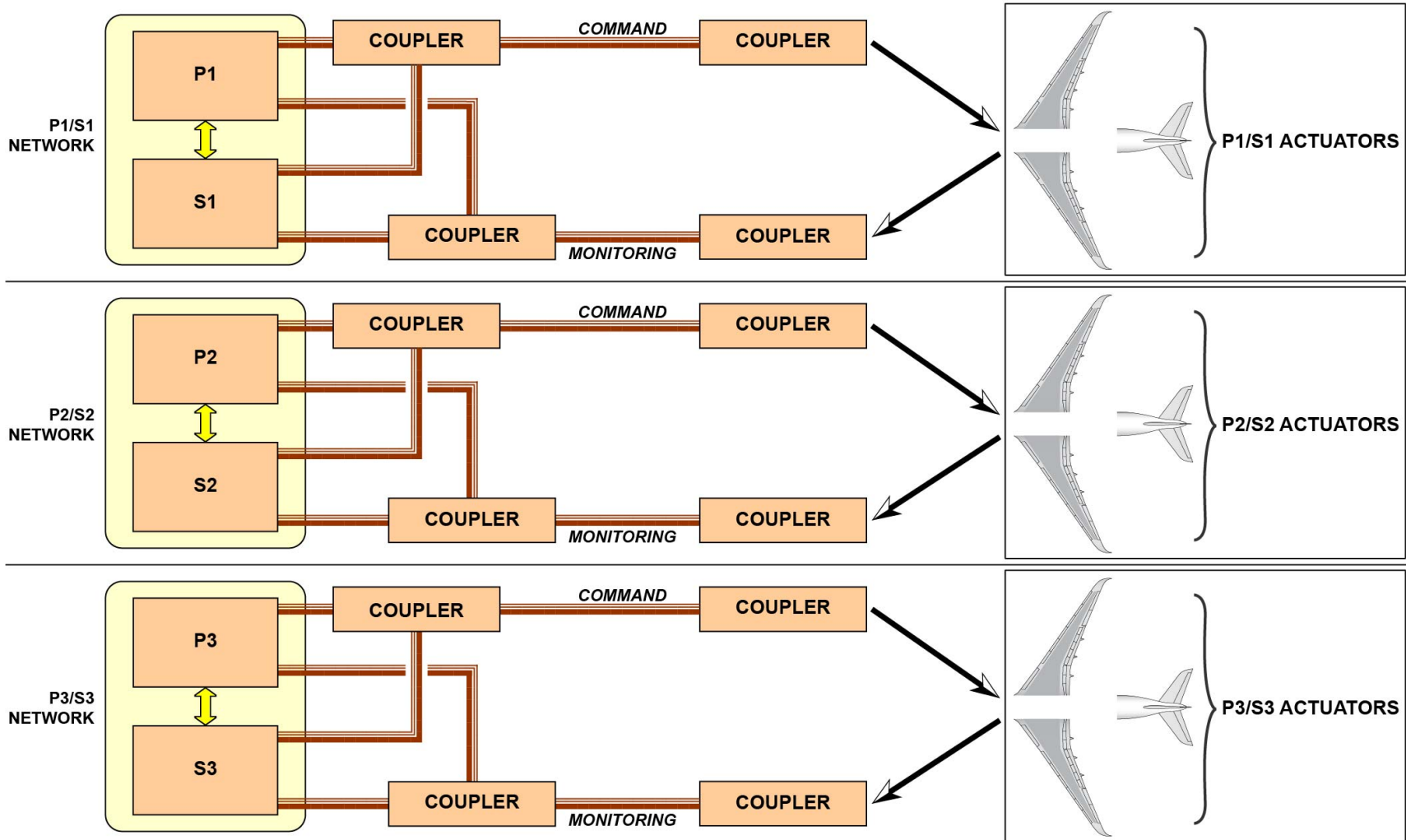

FLIGHT CONTROL ARCHITECTURE

V1813401 - V01T0M0 - VM27D2PCOMP3001

---

## PFCS COMPUTERS GROUP DESCRIPTION (3)

### MIL 1553 Flight Control Architecture

In each network, a pair of computers (PRIMX and SECX) controls dedicated actuators. In normal condition, the PRIMX is in charge. If the PRIMX becomes unavailable, the SECX takes over. If PRIMX and SECX are lost, all the related actuators are declared as non-active actuators. Couplers are installed in each digital network. Each A/C section (L/H wing, R/H wing and tail) uses command buses and couplers segregated from the monitoring buses and couplers. Couplers are used to connect computers and components to the same bus. They are used to save weight by decreasing the number of wires between computers and actuators. Couplers are passive elements and do not have any software. Couplers are installed in pressurized areas with easy access for the removal and installation.

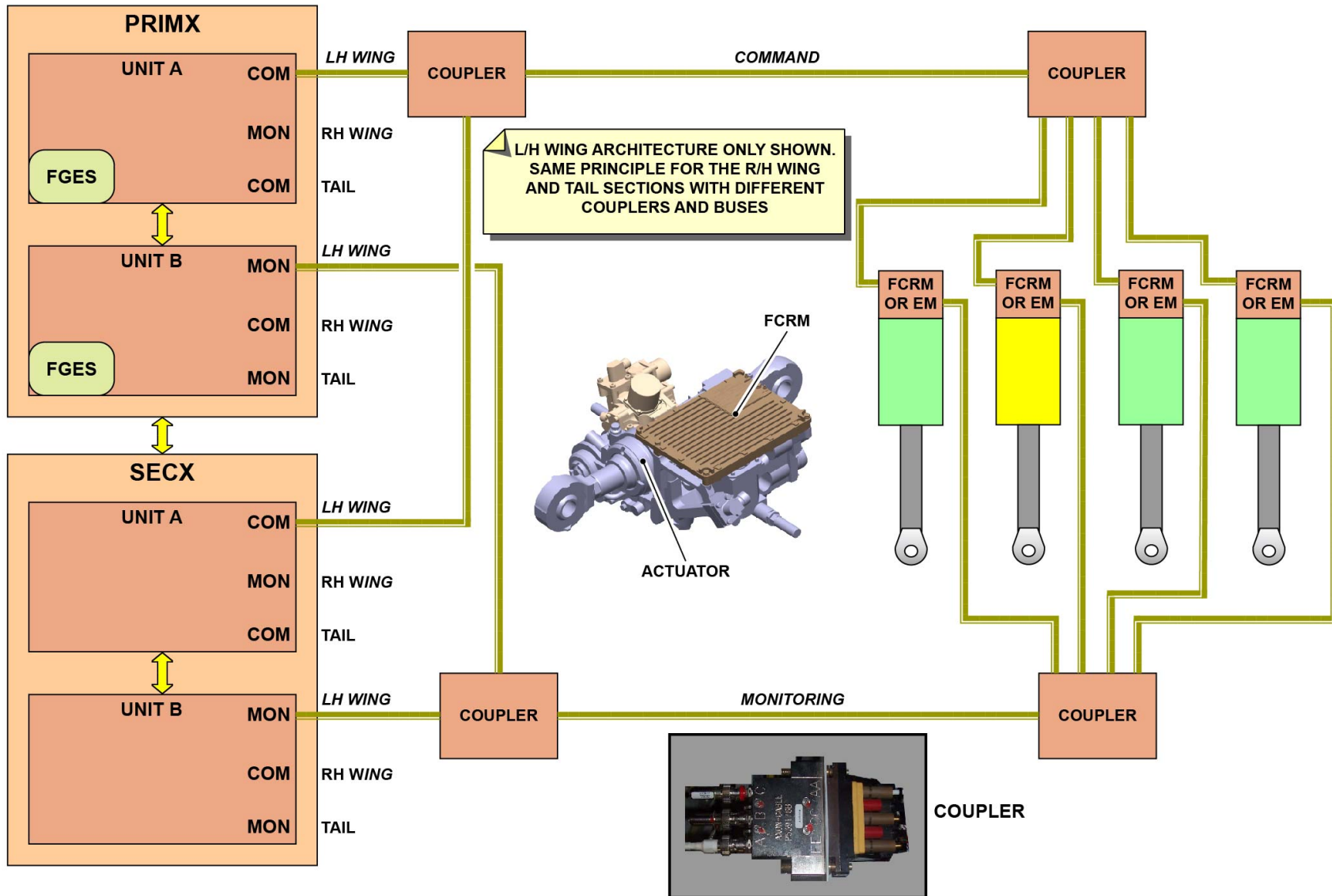

MIL 1553 FLIGHT CONTROL ARCHITECTURE

V1813401 - V01T0M0 - VM27D2PCOMP3001

## PFCS COMPUTERS GROUP DESCRIPTION (3)

### **Power Supply: Computer, Actuator and FCRM/Electronic Modules**

Each PRIM and SEC is electrically supplied by 28VDC from different buses.

Each servo-control actuator FCRM is electrically supplied (60VDC) from the PRIMs or the SECs. These power lines are independent of MIL 1553 and their routing is done through specific wires outside the MIL 1553 network.

When PRIMX correctly operates, it supplies the servo-control actuator FCRM with 60VDC. If PRIMX becomes INOP or is disconnected (pushbutton switched off), the SECX computer takes over and sends 60VDC to the FCRM.

Each EHA and EBHA electronic module is electrically supplied (60VDC) from the PRIMs or the SECs. These power lines are independent of MIL 1553 and their routing is done through specific wires outside MIL 1553 network.

When PRIMX correctly operates, it supplies the EHA/EBHA electronic modules with 60VDC. If PRIMX becomes INOP or is disconnected (pushbutton switched OFF), the SECX computer takes over and sends 60VDC to the electronic modules.

A 230VAC power supply is also sent to the electric motor installed in the EHA and EBHA. This power supply is sent through a Remote Control Circuit Breaker (RCCB) which is activated with a discrete signal from the PRIMX or the SECX (see figure 2).

The EHA and EBHA operation is activated in case of hydraulic and/or electrical failures. The Engine Interface Function (EIF) applications and the Hydraulic Monitoring and Control Applications (HMCA) interface with all the PRIMs and SECs.

On ground, to test and operate the EHAs and/or the EBHAs, we need the following:

- One hydraulic system pressurized or
- One engine running.

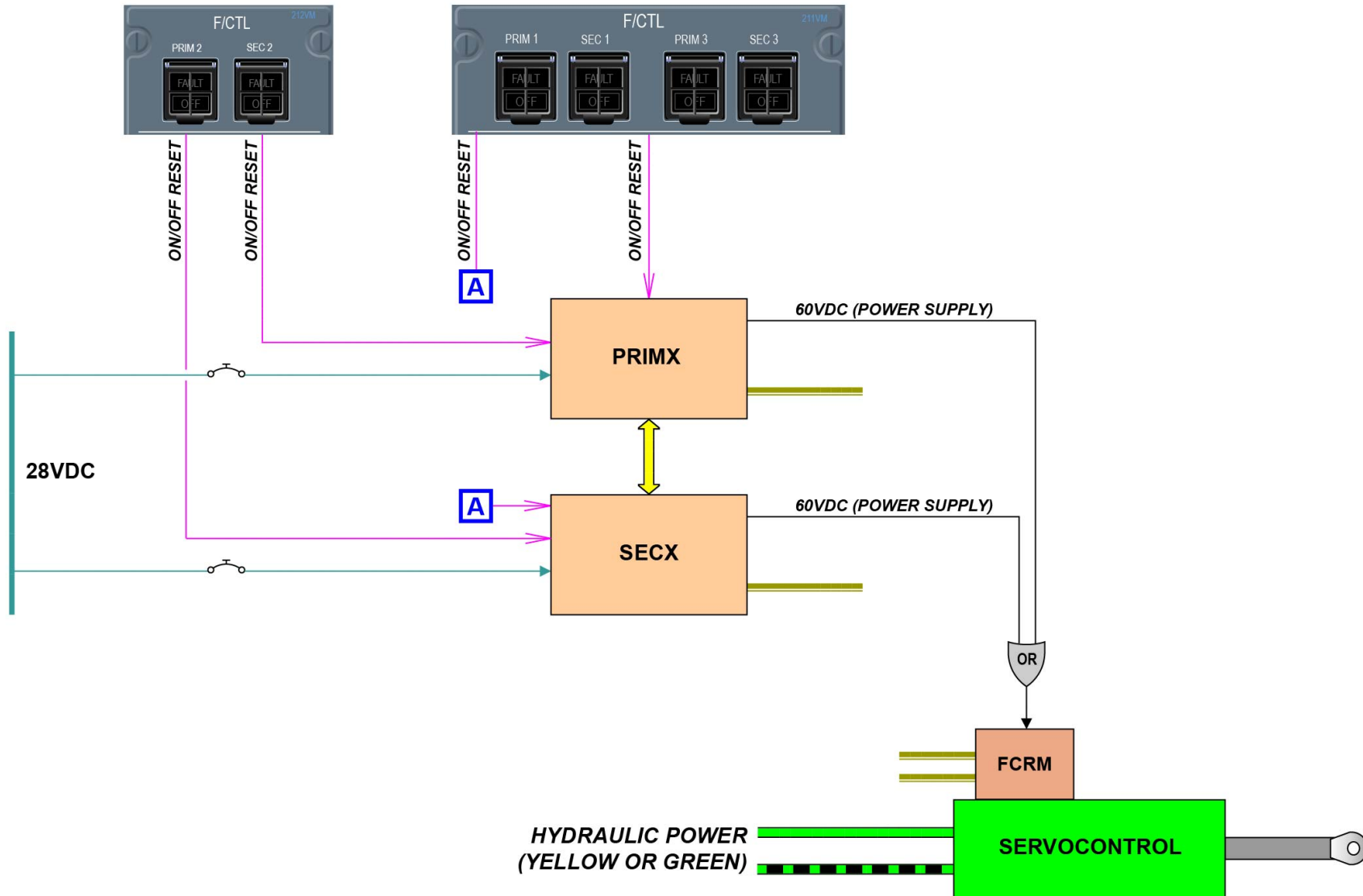

POWER SUPPLY: COMPUTER, ACTUATOR AND FCRM/ELECTRONIC MODULES

V1813401 - V01T0M0 - VM27D2PCOMP3001

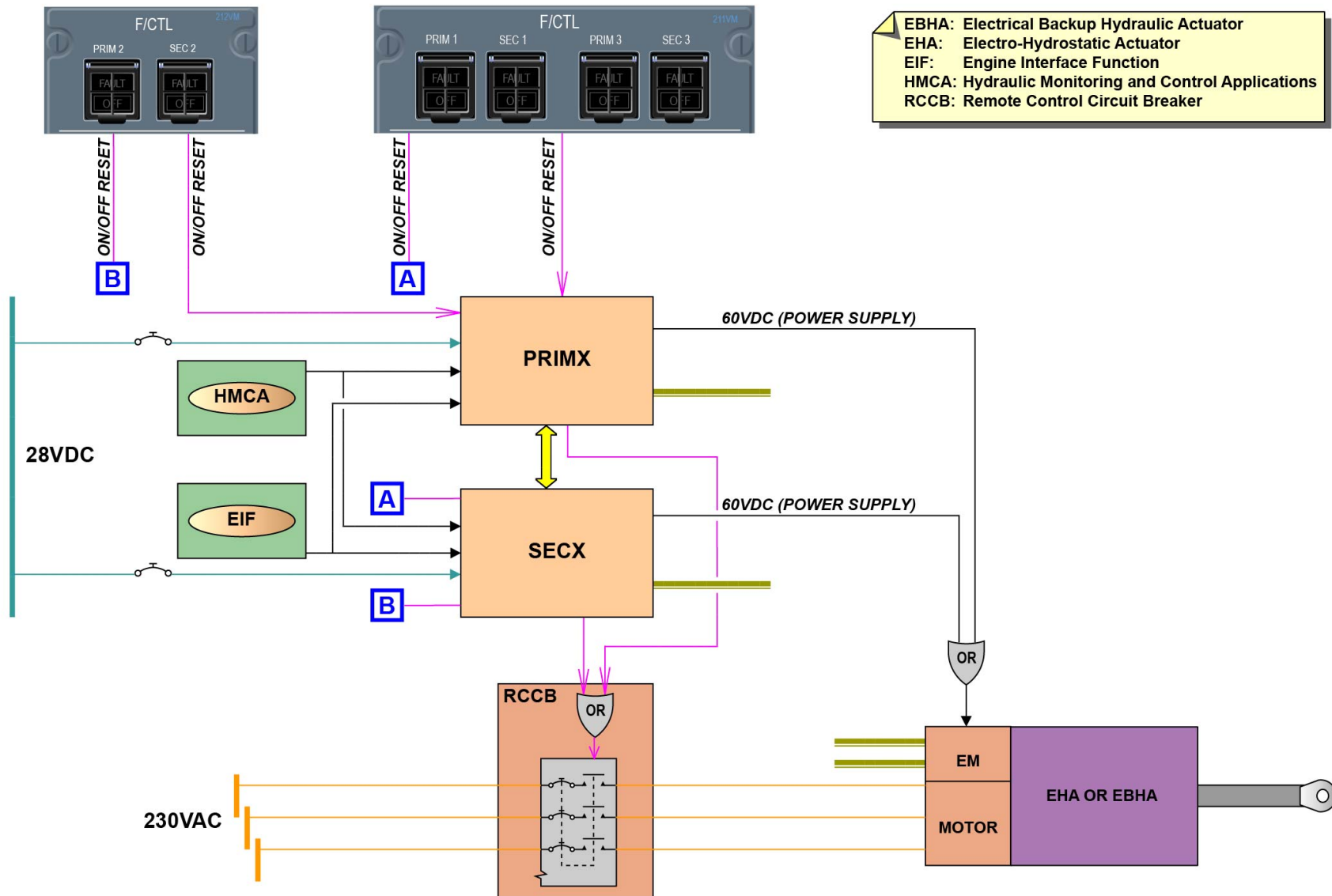

POWER SUPPLY: COMPUTER, ACTUATOR AND FCRM/ELECTRONIC MODULES

V1813401 - V01T0M0 - VM27D2PCOMP3001

This Page Intentionally Left Blank

## PFCS COMPUTERS GROUP DESCRIPTION (3)

### **Interfaces Systems to Primary Flight Control System (PFCS)**

The PRIMs and the SECs receive from each hydraulic circuit:

- The green/yellow hydraulic circuit pressure status (high or low)
- The green/yellow hydraulic circuit pressure value (pressure in PSI).

The PRIMs and SECs determine the hydraulic status (high or low hydraulic pressure) from these different sources of information. Then, information is used to reconfigure the system (engagement of the computers and actuators).

Based on the comparison of the two system manifold pressure transducers and pressure switch, each PRIM can determine the hydraulic status (high or low). Each SEC receives the hydraulic status from the PRIM. The SECs also acquire directly the pressure status (high or low) from the system manifold pressure switch and use it if there is a PRIM failure. The status of the hydraulic circuit pressure is given by the HP manifold pressure transducers of the engine driven pump to the PRIMs via the CRDCs through the CPIOMs and the AFDX network. This information is used by the PRIM to keep the hydraulic consumption to a minimum if there is one engine driven pump failure.

From the Slat Flap Control Computers (SFCCs), the PRIMs and SECs receive:

- The flap/slat positions to compute the flight control laws.
- The flap positions for the Adaptive Droop Hinge Function (ADHF).



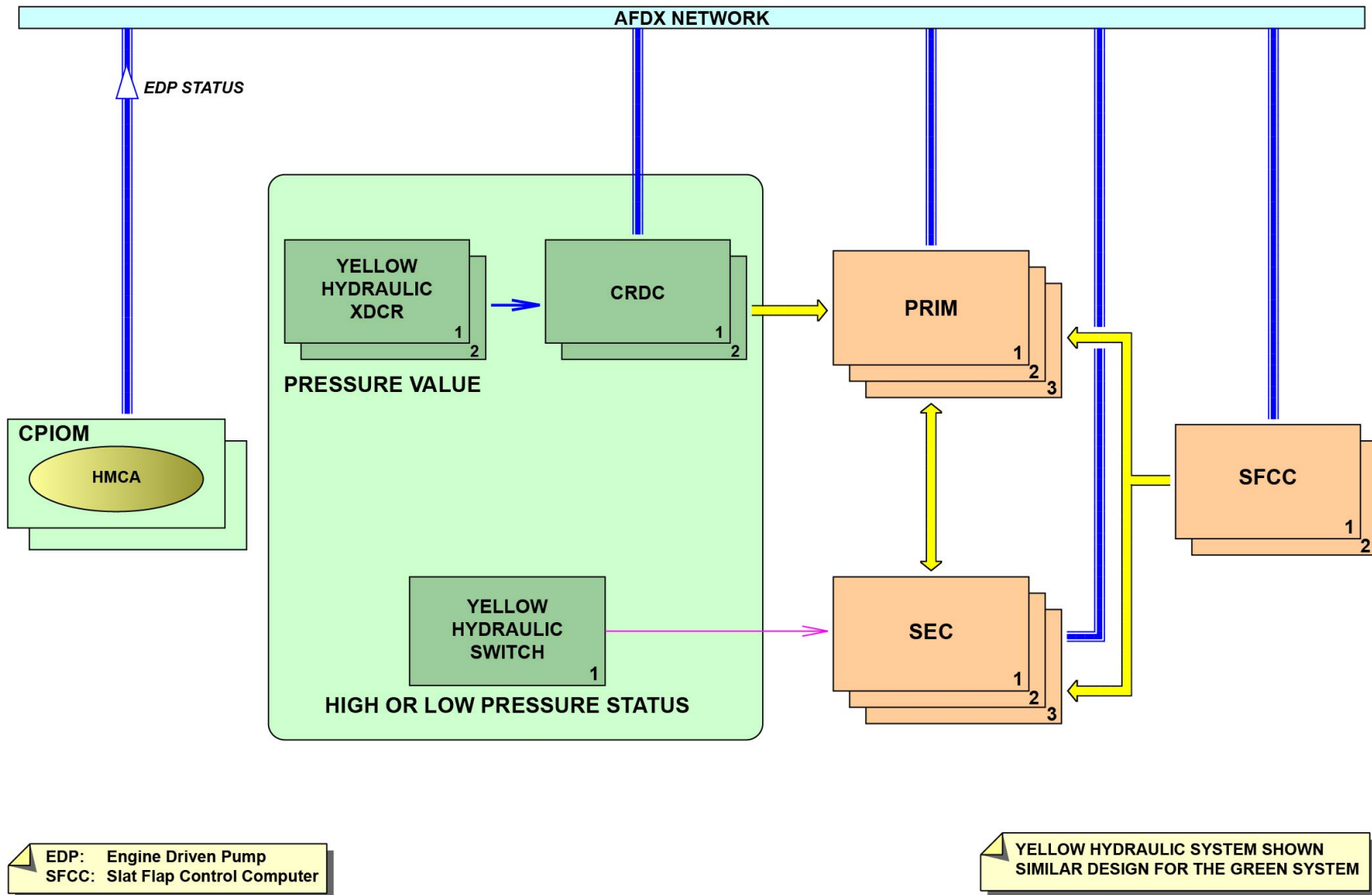

EDP: Engine Driven Pump  
SFCC: Slat Flap Control Computer

YELLOW HYDRAULIC SYSTEM SHOWN  
SIMILAR DESIGN FOR THE GREEN SYSTEM

INTERFACES SYSTEMS TO PRIMARY FLIGHT CONTROL SYSTEM (PFCS)

V1813401 - V01T0M0 - VM27D2PCOMP3001

## PFCS COMPUTERS GROUP DESCRIPTION (3)

### **A/C Sensors and Load Alleviation Function (LAF)**

Attitude and air data are necessary for the PRIMs to compute the control laws. This data comes from 3 ADIRUs and 6 RGAUs. The ADIRUs send attitude and position information and the RGAUs send inertial data. If RGAUs are lost, the ADIRUs take over with their inertial reference data. The LAF is done by the PRIMs only. The Multi Function Probe (MFP) sends data for the LAF computation.

The Integrated Standby Instrument System (ISIS) sends inertial data and air data through dedicated sensors. This data is used to consolidate ADIRU parameters and is not used to compute the flight control laws.

A PFCS (4th AOA probe) (only used for ATA 27) is used to consolidate the ADIRU parameters to the PRIMs and is used to compute the laws.

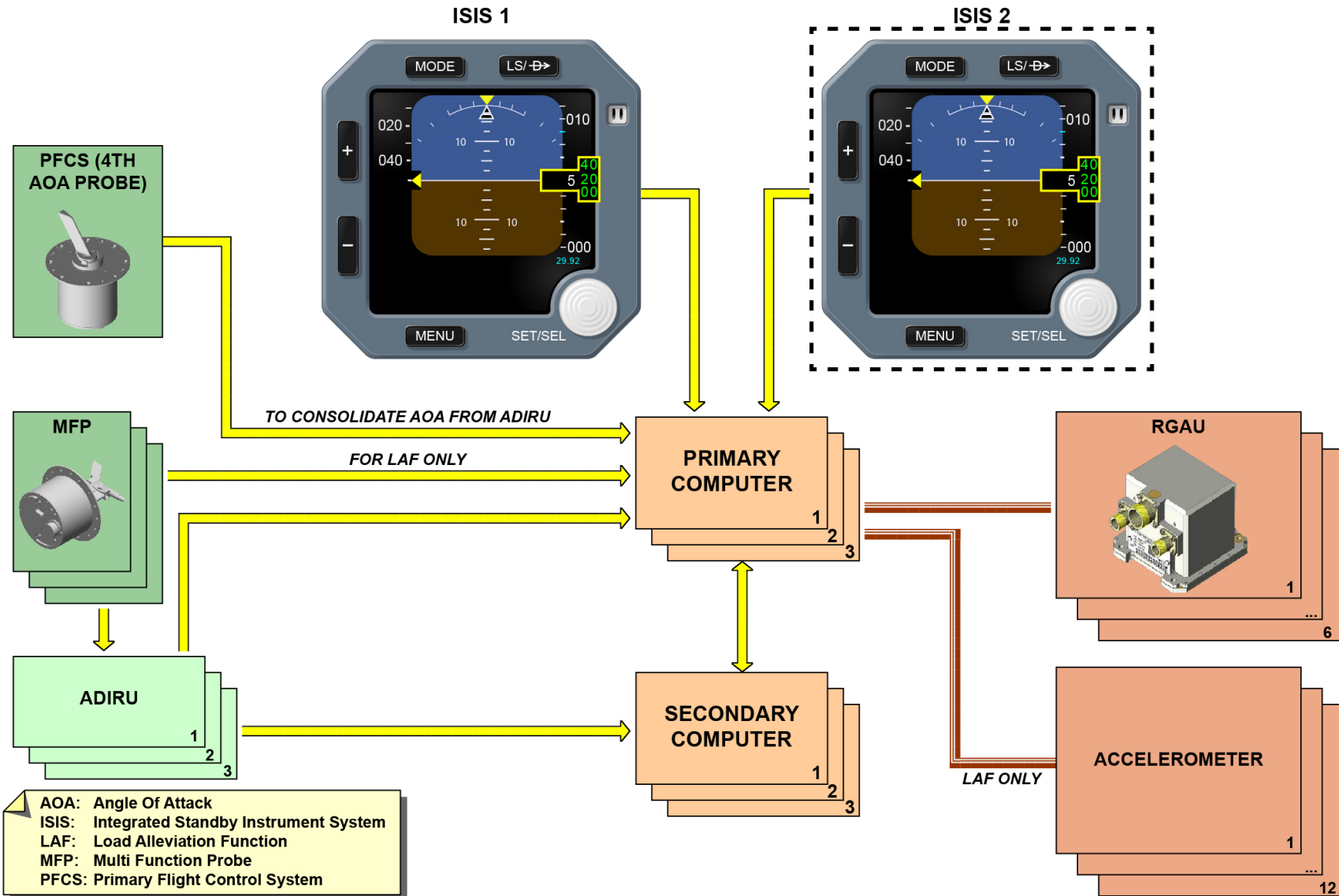

A/C SENSORS AND LOAD ALLEVIATION FUNCTION (LAF)

V1813401 - V01T0M0 - VM27D2PCOMP3001

---

## PFCS COMPUTERS GROUP DESCRIPTION (3)

### **Load Alleviation Function**

The Load Alleviation Function (LAF) is a protection to reduce wings loads during maneuvers or gusts. The objective is to modify the span-wise lift distribution with ailerons and/or spoilers upper deflections to reduce momentarily the wing bending moment. Roll orders have always the priority over the LAF.

The LAF includes:

- The Maneuver Load Alleviation (MLA)
- The Gust Load Alleviation (GLA).

The MLA is activated when a load factor created by a pilot maneuver order exceeds a limit.

- For positive load factor it deflects inboard and outboard ailerons (symmetrically).
- For negative load factors exceeding a threshold, the spoilers 1 and 2 and outboard ailerons will deflect symmetrically.

The GLA function is introduced in the PRIMs to reduce loads on the wing during discrete gusts and turbulence. The GLA deflects inboard and outboard ailerons upwards (symmetrically) when gust or excessive turbulence is detected.

GLA: Gust Load Alleviation  
 MLA: Maneuver Load Alleviation

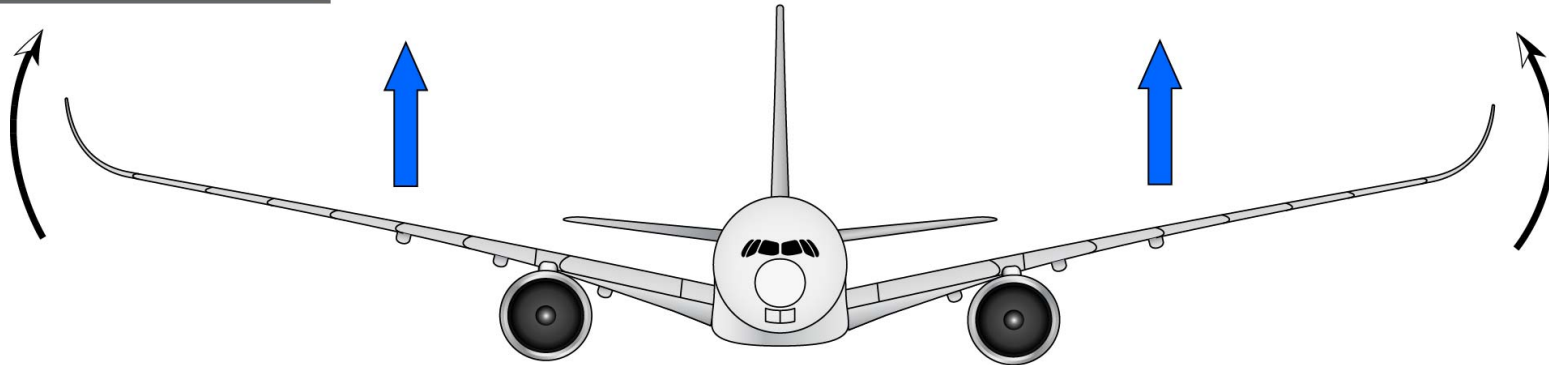

**WING BENDING DUE TO LIFT**

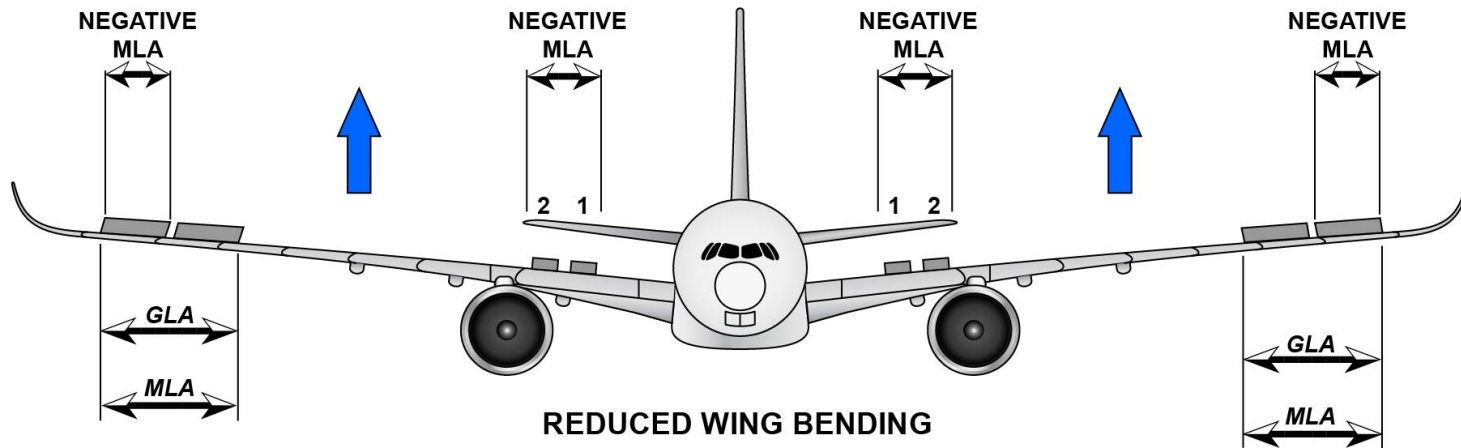

**REDUCED WING BENDING**

**LOAD ALLEVIATION FUNCTION**

V1813401 - V01T0M0 - VM27D2PCOMP3001

## PFCS LATERAL FUNCTION DESCRIPTION (3)

### Lateral Function: Roll Description

The roll control is performed by:

- The inboard ailerons
- The outboard ailerons
- The spoilers 3 to 7.

It is initiated from the Side Stick Units (SSU) or the Auto Flight System (AFS) as a roll command request sent to all the computers (PRIMary (PRIMs) and SECondary (SECs)).

The PRIMs and SECs also receive A/C attitude data (from Air Data/Inertial Reference System (ADIRS), Rate Gyro and Accelerometer Units (RGAUs)) for computation of the ailerons and spoilers deflection. The surface deflection is done by the actuators based on the computers orders.

Each aileron moves a position transducer (Rotary Variable Differential Transducer (RVDT)) to give a surface position feedback to the computers through the Flight Control Remote Module (FCRM) or the electronic module for monitoring purposes.

At low speed, all ailerons are used while at high speed only the inboard ailerons are used. At high speed, the outboard ailerons are kept at neutral position (above 240 kts).

The spoilers 3 to 7 move upward during the roll maneuvers for a roll control.

When the flaps are extended (data from the Slat Flap Control Computers (SFCCs)), all ailerons are moved down 10 degrees. This gives more lift during the take-off and the landing.

Each actuator is controlled and monitored by a set of the PRIMs and SECs through a Command (COM) and a Monitor (MON) digital network (MIL 1553). Each computer is in charge of several actuators.

Each actuator has a FCRM or an electronic module. They exchange data with the computers and convert digital data into analog and discrete signals for the actuator components (solenoid valves, transducers, etc).

The FCRM or the electronic module performs the servo-loop function

on each actuator. The analog and discrete signals from the actuator components are also converted by the FCRM or the electronic module into digital data for the computers.

Each inboard aileron is actuated by:

- One hydraulic servo-control actuator
- One Electro-Hydrostatic Actuator (EHA).

In normal operation, the servo-control operates in active mode and moves the aileron while the EHA operates in hard damping mode (driven by the surface).

If the servo-control fails then:

- The EHA operates in active mode
- The servo-control operates in hard damping mode.

Each outboard aileron is operated by two hydraulic servo-controls. In normal operation, each servo-control operates in active mode and moves at the same time (load sharing function).

They have 3 modes of operation:

- Active damping mode
- Hard damping mode
- Soft damping mode.

If one actuator fails, it operates in soft damping mode.

If the two actuators fail, they operate in hard damping mode.

Note: on ground, with no hydraulic pressure applied, the hard damping mode performs the damping of the moving surfaces in case of wind gust.

Each SSU has an integrated solenoid. When the Autopilot (AP) is engaged, the solenoid is energized and increase the force needed to move the SSU. Above a certain force applied on the side stick unit, the AP disengages.

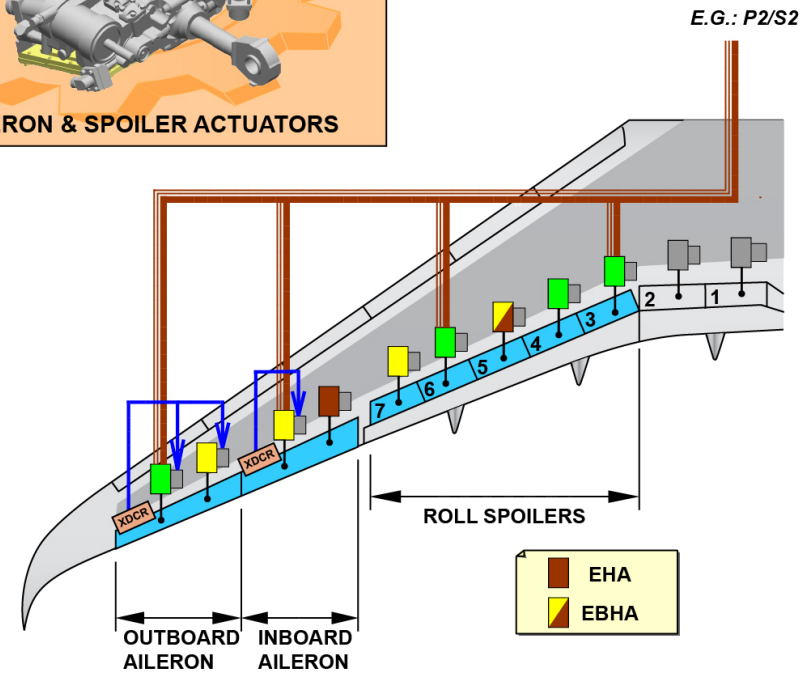
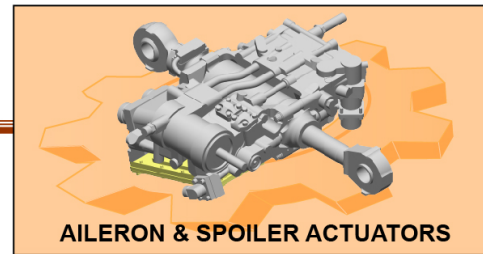
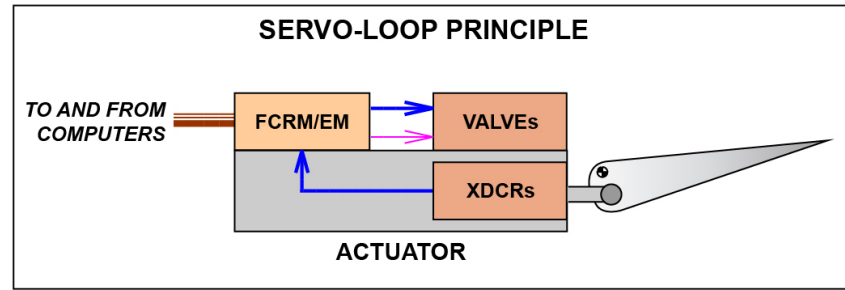
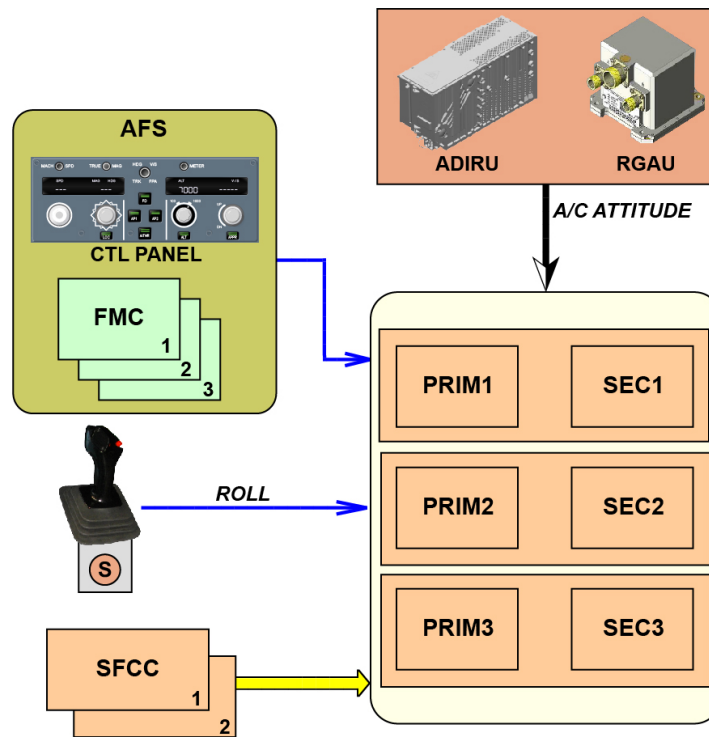

- ADIRU: Air Data/Inertial Reference Unit
- AFS: Automatic Flight System
- EBHA: Electrical Backup Hydraulic Actuator
- EHA: Electro-Hydrostatic Actuator
- EM: Electronic Module
- FCRM: Flight Control Remote Module
- FMC: Flight Management Computer
- PRIM: PRIMary Computer
- RGAU: Rate Gyro and Accelerometer Unit
- SEC: SECondary Computer
- SFCC: Slat Flap Control Computer
- XDCR: Transducer

LATERAL FUNCTION: ROLL DESCRIPTION

V1813401 - V01T0M0 - VM27D4-AGLAT3001

## PFCS LATERAL FUNCTION DESCRIPTION (3)

### Lateral Function: Yaw Description

The yaw control is achieved by the rudder.

The yaw orders are sent to all computers (PRIMs and SECs) as a yaw command request based on inputs from:

- The rudder pedals via transducers or
- The AFS or
- The SSUs (for the turn coordination function) or
- The rudder trim control panel.

For the computation of the rudder deflection, the PRIMs and SECs receive the A/C attitude data (ADIRS, RGAUs).

The surface deflection is done by the actuators based on the computers orders.

The rudder travel range is proportional to the A/C speed. It is progressively reduced when the speed increases to prevent too much loads on the aircraft structure.

The system also provides a yaw damping function (Dutch roll damping). The rudder moves two position transducers (Rotary Variable Differential Transducer (RVDT)) to give the surface position feedback to the computers through the FCRM or the electronic module for monitoring purposes.

A Pedal Damper and Friction Unit (PDFU) is linked to the pedals to give a resistance related to the A/C speed which improves the pilots feel.

The actuator servo-loop principle is same as the aileron principle (excepted the hard damping function that hard wired to the actuators).

The rudder has two servo-control actuators and one EHA.

In normal operation, each servo-control actuator operates in active mode and actuates simultaneously the rudder with a load sharing function. At the same time, the EHA operates in hard damping mode (cruise) or in soft damping mode (ground, take-off or landing).

If one servo-control actuator fails:

- Both servo-control actuators operate in the soft damping mode
- The EHA becomes active.

Note: on ground, with no hydraulic pressure applied, the hard damping mode performs the damping of the moving surfaces in case of strong wind gust.

The Pedal Feel and Trim Unit (PFTU) is connected to the pedals linkage.

The functions of the PFTU are:

- To set the rudder to a new neutral position.
- To give the artificial feel to the rudder pedals.
- To stiffen the movement of the rudder pedals when the AP is engaged.

When the rudder trim control panel is used, it sends trim order signals to the SEC2 and SEC3. Then, the SEC2 and SEC3 energize the PFTU electrical motors (one active, one standby) through their electronic modules.

The PFTU electric motors create rudder pedal and rudder pedal transducer movements. Based on the pedal transducer signals received by the PRIMs and SECs, the rudder is moved to a new neutral position.

Specific sensors send the rudder pedal linkage position to the PRIM2/SEC2 and PRIM3/SEC3.

The trim transducers installed in the PFTU send trim order feedback signals to the SEC2 and SEC3 (only when the rudder is trimmed).

The AP solenoid (on the PFTU) is energized when the AP is engaged.

The solenoid increases the force needed to move the pedals.

The rudder trim control panel (selector and reset pushbutton) is inhibited when the AP is engaged.



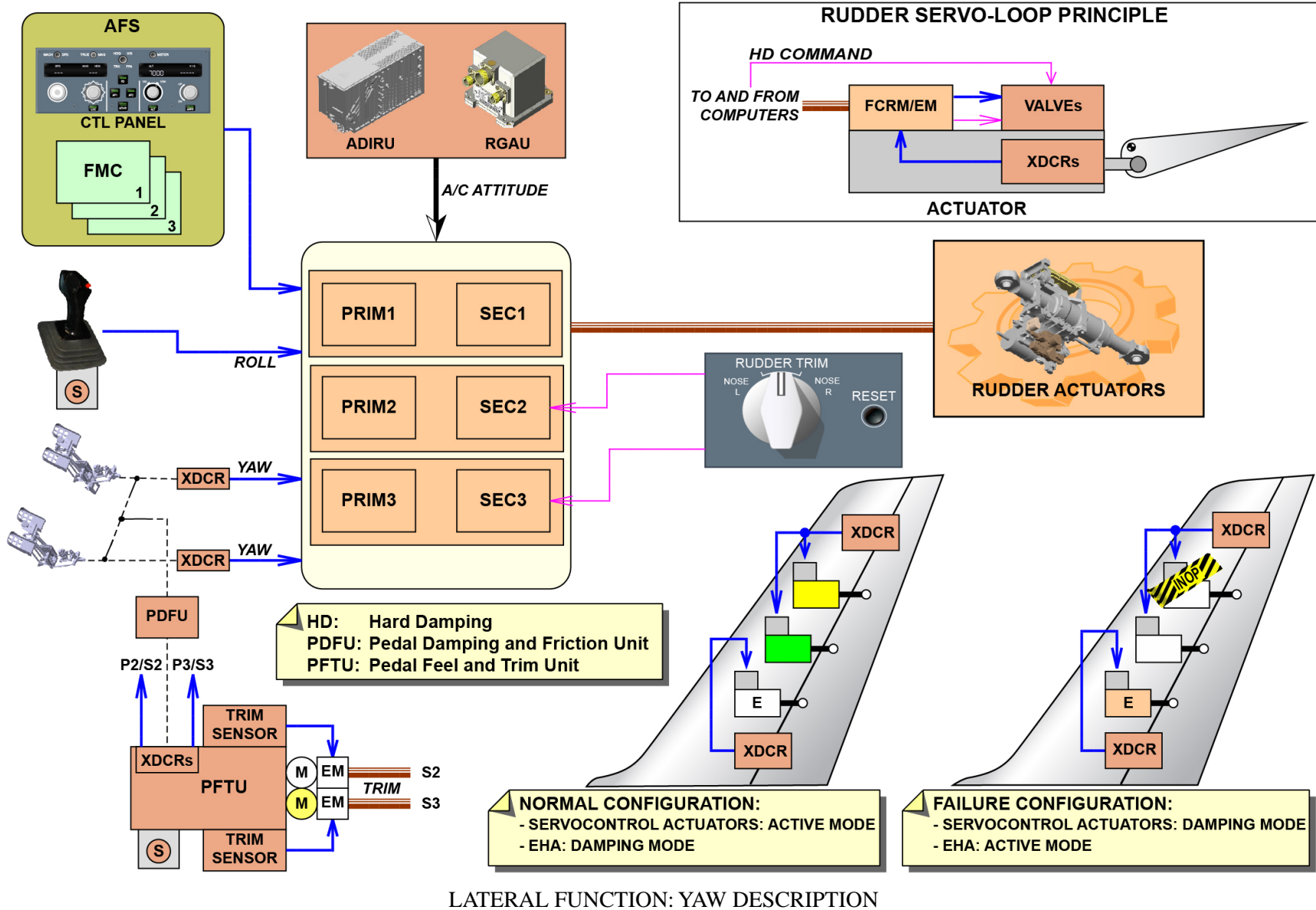

V1813401 - V01T0M0 - VM27D4AGLAT3001

---

## PFCS LATERAL FUNCTION DESCRIPTION (3)

### **PFTU and Pedal Kinematic**

The pedals move:

- The PFTU
- The PDFU
- Rods and transducers.

These equipments are installed below the cockpit floor.

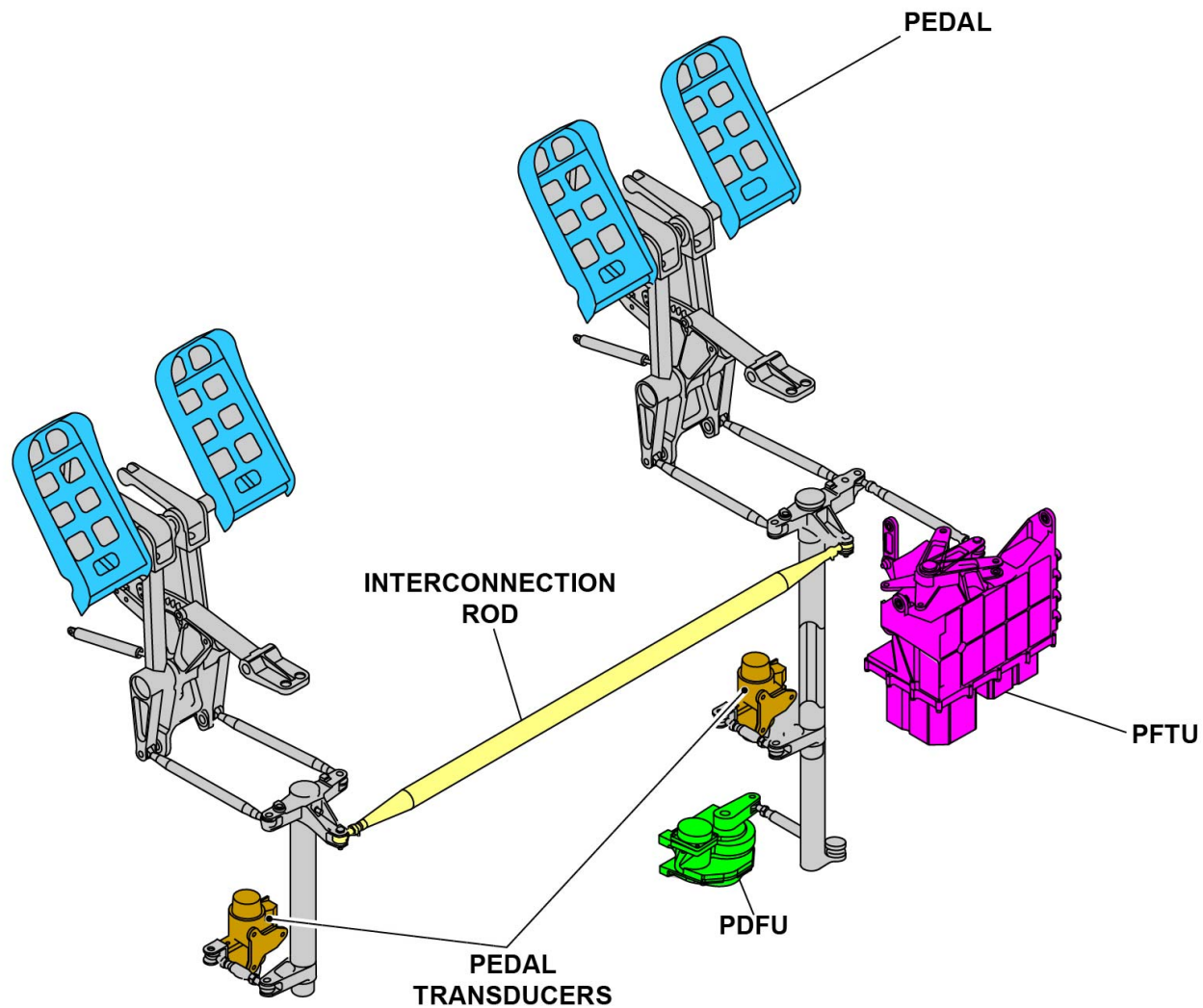

**PFTU AND PEDAL KINEMATIC**

V1813401 - V01T0M0 - VM27D4AGLAT3001

---

## PFCS LATERAL FUNCTION DESCRIPTION (3)

### **Actuators Group: Actuators Hard/Soft Damping Mode**

The ailerons, elevators and rudder flight control actuators have three modes of operation:

- The active mode used to move the surfaces
- The soft damping mode: moved by the surfaces (allows required performance when the adjacent actuator is in the active mode)
- The hard damping mode: moved by the surfaces (higher restrictions than the soft damping mode to prevent surface flutter).

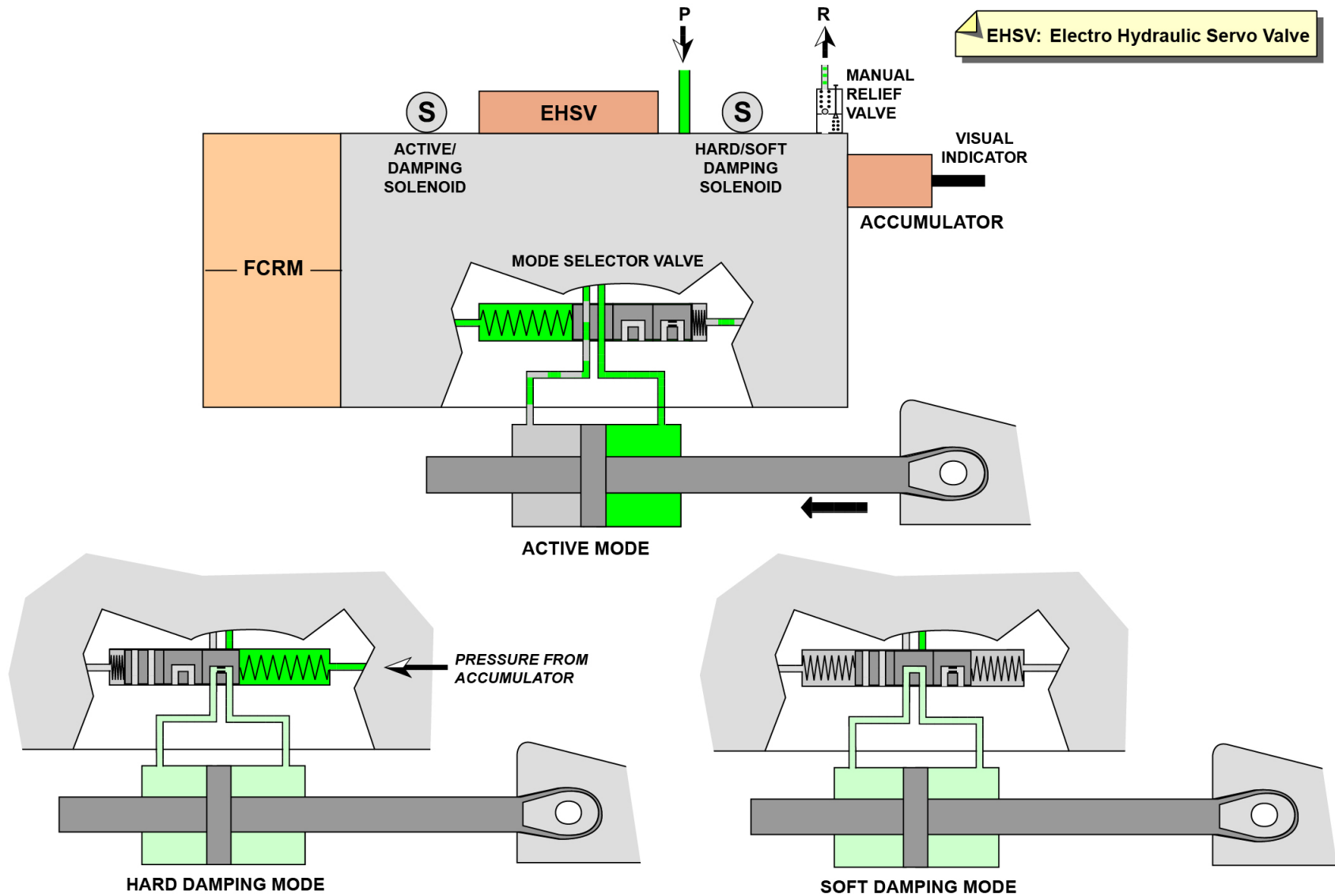

V1813401 - V01T0M0 - VM27D4AGLAT3001

## PFCS LATERAL FUNCTION DESCRIPTION (3)

### Actuators Group: Servo-controls

Each servo-control actuator has a FCRM that exchanges data with the computers.

Each FCRM has two units:

- One COM
- One MON.

They exchange data through an internal bus to perform the servo-loop function.

The COM function is:

- To receive a surface deflection orders from the computers
- To receive actuator mode command signals from the computers (active, soft damping, hard damping)
- To control some valves to extend or retract the actuator to achieve the surface deflection orders (control servo-loop).

The MON function is:

- To receive values from the transducers to monitor the actuator operation (feedback servo-loop).
- To prevent the actuator servo-loop if there is a COM failure.

Each servo-control actuator has a solenoid operated mode selector valve.

The mode selector valve:

- Configures the actuator in the active or damping mode (hard or soft).
- Is moved based on signals from the active/damping and hard/soft damping solenoid valves.

Each servo-control actuator has an Electro Hydraulic Servo Valve (EHSV). When a servo-control actuator is in the active mode, the EHSV controls the hydraulic flow and the direction to the actuator chambers.

An accumulator gives the pressurized hydraulic fluid to keep the damping mode (when used).

The accumulator has a visual level indicator to check:

- The accumulator condition
- The actuator internal leakages.

The accumulator and residual hydraulic pressures can be released by a manually operated return relief valve.

To monitor the servo-control actuator operation, various position transducers send analog feedback signals to the FCRM.

The EHSV, mode selector valve, piston rod and chamber pressure signals are used for the feedback servo-loop and test purposes.

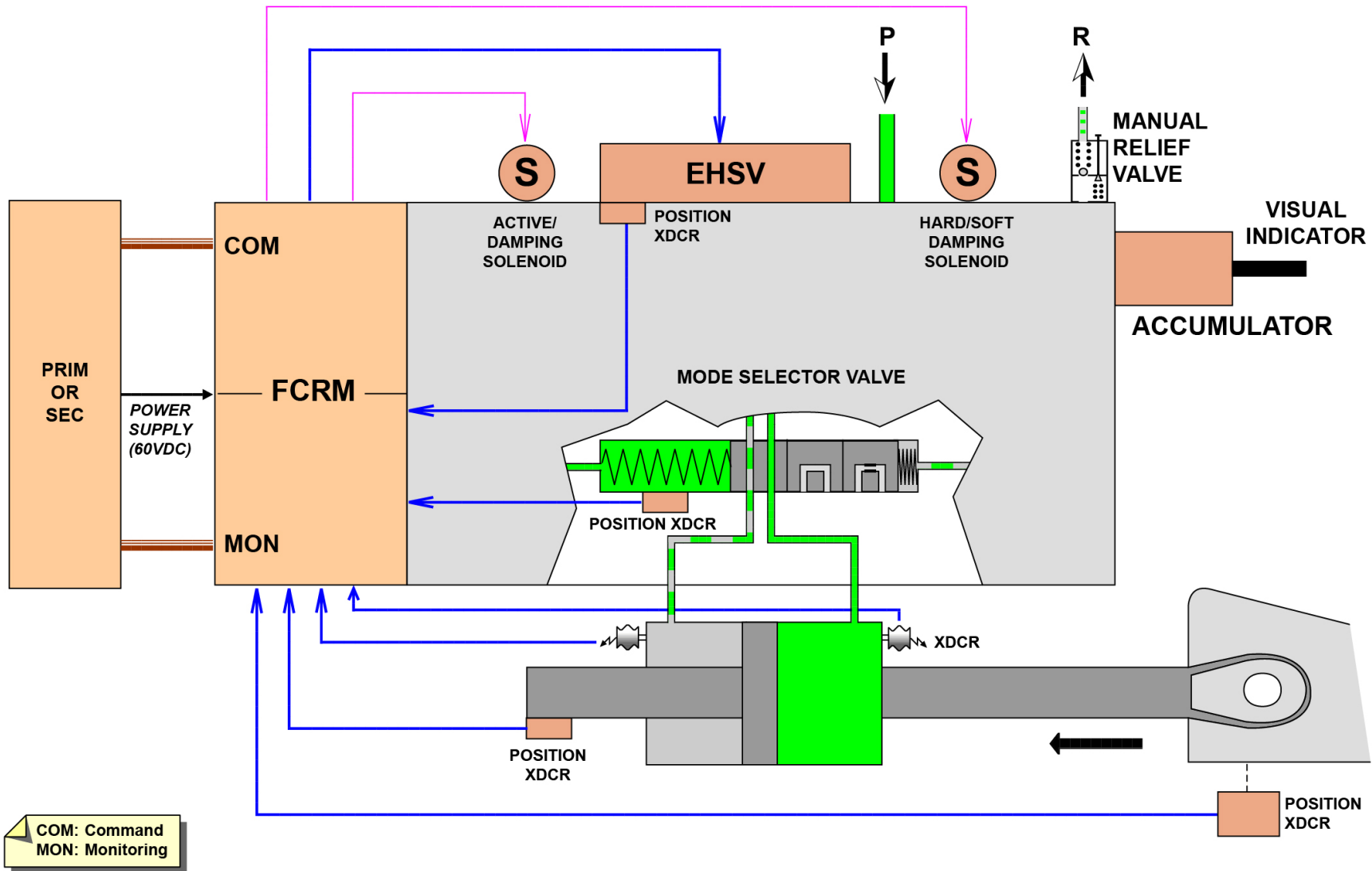

ACTUATORS GROUP: SERVO-CONTROLS

V1813401 - V01T0M0 - VM27D4AGLAT3001

## PFCS LATERAL FUNCTION DESCRIPTION (3)

### **Actuators Group: Servo-controls Components**

Each servo-control actuator is composed of different elements such as:

- A FCRM
- An EHSV
- An active/damping solenoid valve
- A soft/hard damping solenoid valve
- Transducers.

Each servo-control actuator has two different sides:

- A hydraulic side with all hydraulic components
- An electronic side isolated from the hydraulic side.

The FCRM is installed in the electronic side. Each FCRM has two connectors:

- One for the COM
- One for the MON.

The EHSV and the hard/soft damping solenoid valve are installed in the hydraulic side.



**RUDDER SERVOCONTROL**

**INBOARD AILERON SERVOCONTROL**

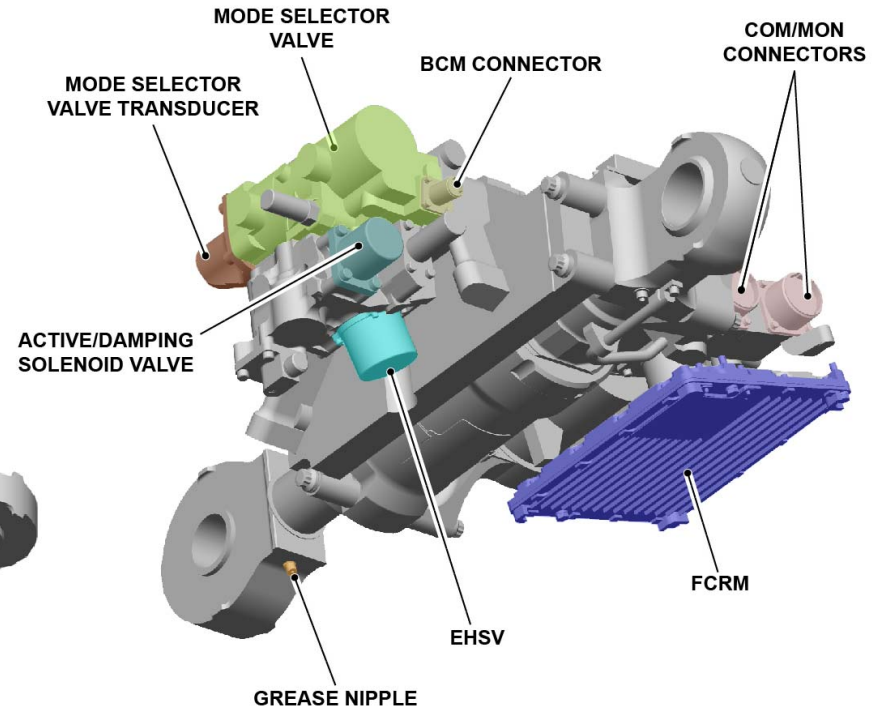
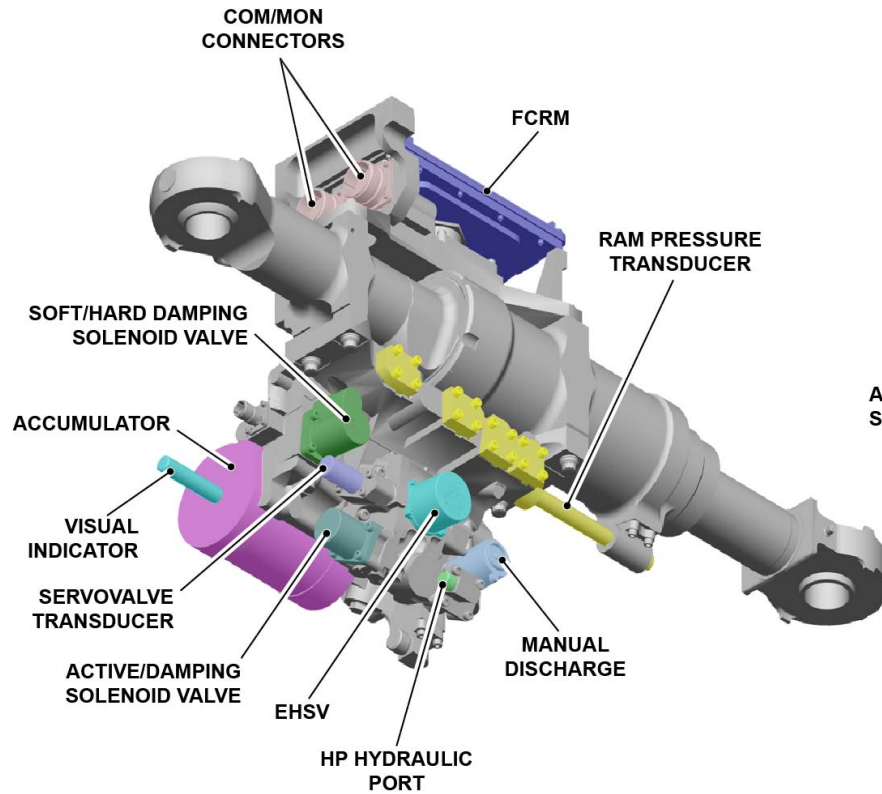

**BCM: Backup Control Module**

**ACTUATORS GROUP: SERVO-CONTROLS COMPONENTS**

V1813401 - V01T0M0 - VM27D4AGLAT3001

## PFCS LATERAL FUNCTION DESCRIPTION (3)

### Actuators Group: EHA Principle

Each EHA has an electronic module with two units (COM and MON). They have the same functions as the COM and MON units of the FCRM. A third unit called power electronics is installed on the electronic module (physically and electrically segregated). It converts AC power to DC power (230 VAC to 540 VDC) to supply the electrical motor and the direct drive solenoid.

A mode selector valve configures the EHA in active or damping mode. It is controlled by:

- An active/damping direct drive solenoid valve
- A hard/soft damping solenoid valve.

An accumulator supplies fluid to the EHA. It compensates the fluid volume variations and leakages.

A refilling solenoid valve (when energized) allows the EHA accumulator hydraulic refilling. The opening of the refilling solenoid valve is automatic started by the electronic module or can be launched from the Onboard Maintenance System (OMS).

The accumulator has one visual indicator to check the fluid level. An accumulator pressure transducer is also installed to monitor the accumulator pressure.

A manual operated relief valve is installed at the hydraulic outlet of the EHA to prevent the hydraulic line disconnection with the internal pressure. To monitor the EHA operation, different transducers send analog feedback signals to the electronic module.

The mode selector valve, piston rod positions and chamber pressure signals are used for the servo-loop and test purposes.

The EHA is hydraulically connected to the servo-control actuator hydraulic circuit.

Its connection to the hydraulic circuit is:

- Only used to refill the EHA
- Isolated from the HP hydraulic circuit in flight.

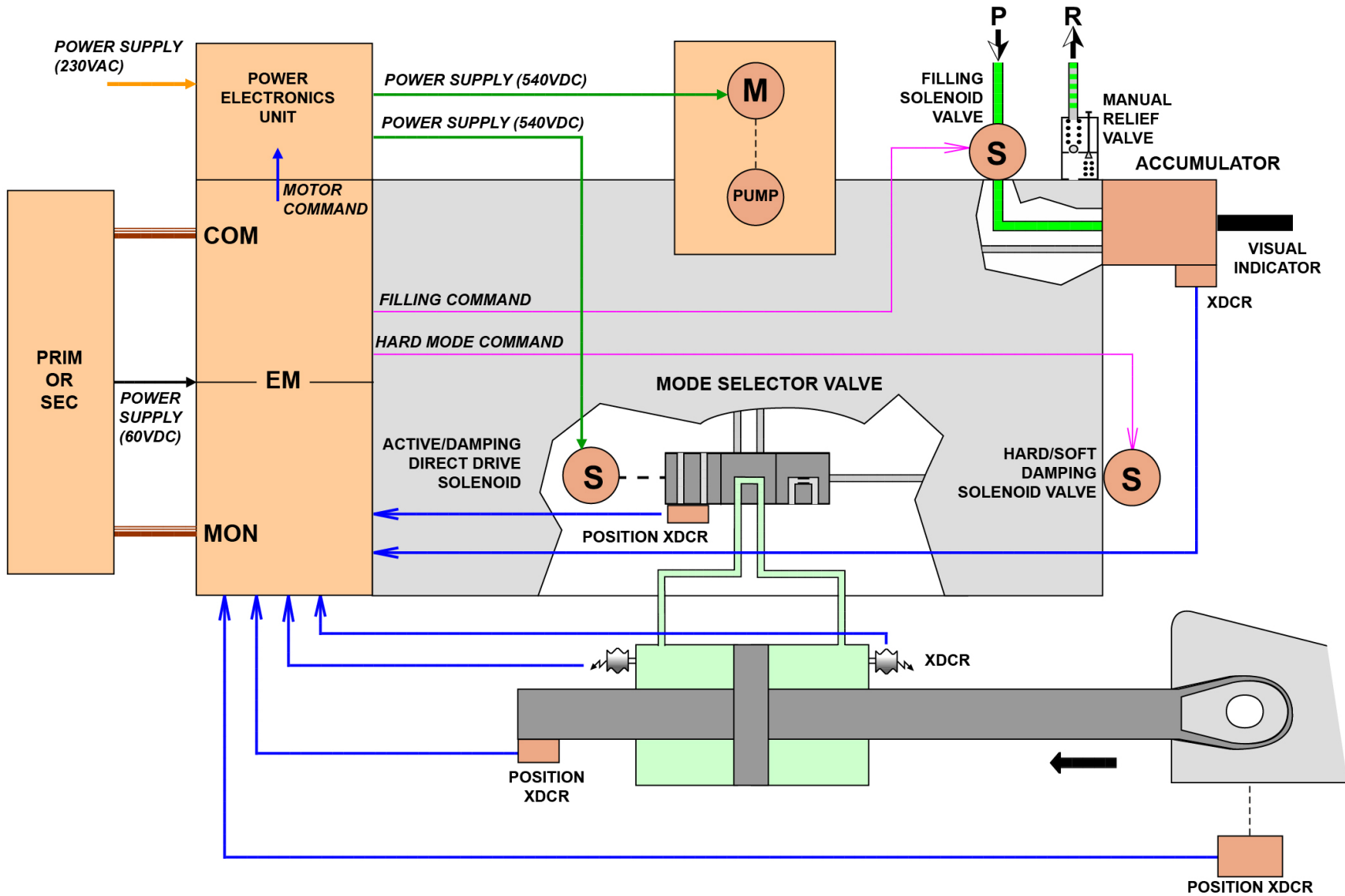

ACTUATORS GROUP: EHA PRINCIPLE

V1813401 - V01T0M0 - VM27D4AGLAT3001

---

## PFCS LATERAL FUNCTION DESCRIPTION (3)

### **Actuators Group Lateral Function: EHA Components**

The EHA is composed of different elements such as:

- An electronic module
- A filling solenoid valve
- A direct drive solenoid valve
- An accumulator.

The EHA have two different sides:

- A hydraulic side with all hydraulic components
- An electronic side isolated from the hydraulic side.

Each electronic module has two connectors:

- One for the COM
- One for the MON.

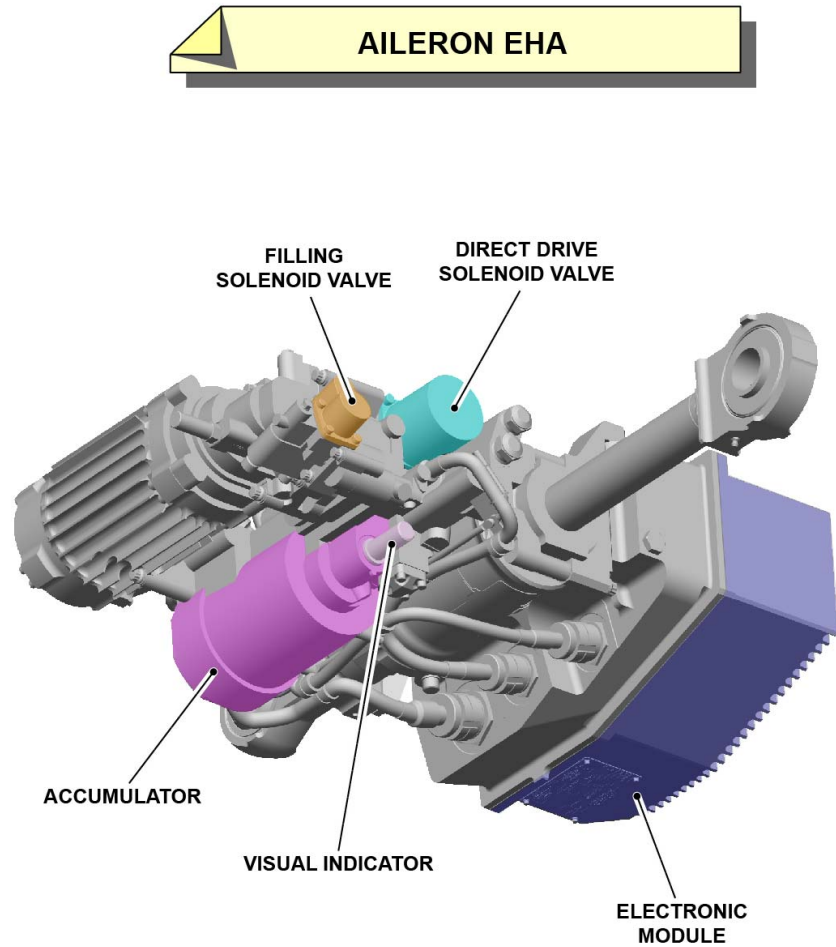
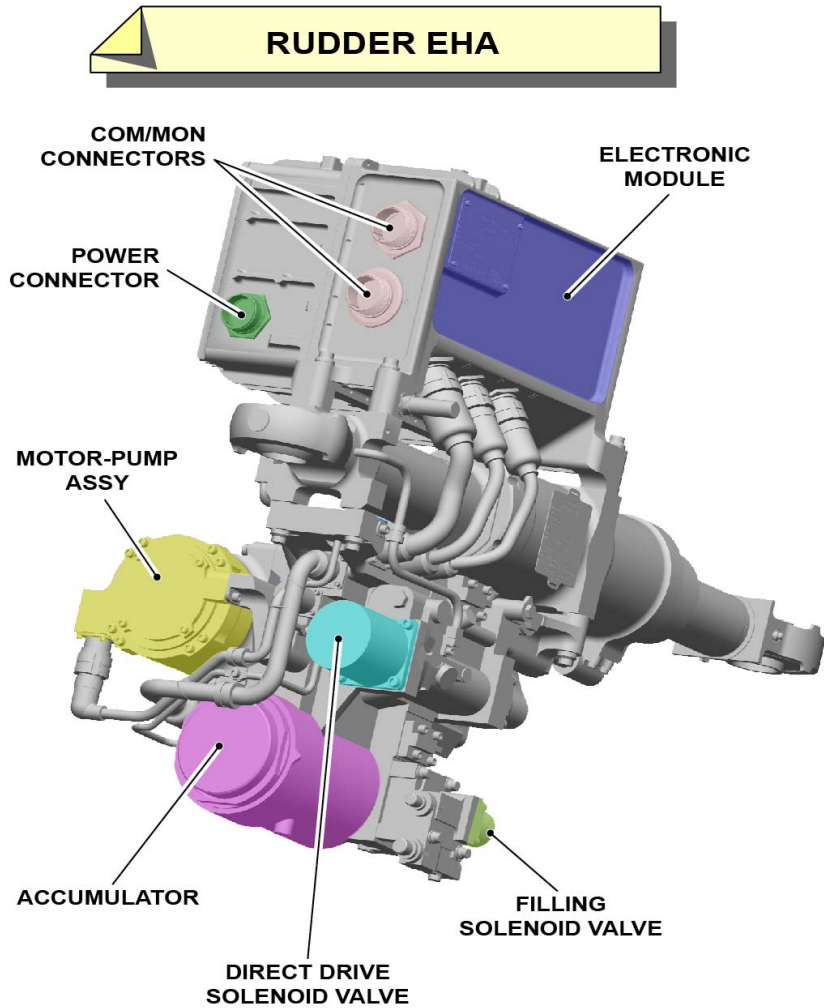

ACTUATORS GROUP LATERAL FUNCTION: EHA COMPONENTS

V1813401 - V01T0M0 - VM27D4AGLAT3001

## PFCS VERTICAL FUNCTION DESCRIPTION (3)

### Actuators Group Vertical Function: Pitch Description

The pitch control is achieved by:

- The two elevators
- The Trimmable Horizontal Stabilizer (THS).

The elevators are used for a short term activity and the THS for a long term activity.

The pitch orders are sent to all computers (PRIMary Computers (PRIMs) and SECondary Computer (SECs)) as a pitch command order based on the inputs from the:

- Side stick Units (SSUs)
- Automatic Flight System (AFS)
- Pitch trim control switches.

For the computation of the THS and elevators deflection, the PRIMs and SECs receive the aircraft attitude data (Air Data/Inertial Reference System (ADIRS), Rate Gyro and Accelerometer Units (RGAs), accelerometers and Integrated Standby Instrument System (ISIS)).

The surface deflection is done by the actuators based on the computers orders.

Each elevator has two Rotary Variable Differential Transducers (RVDTs). They give a surface position feedback to the computers through the Flight Control Remote Module (FCRM) or an electronic module for monitoring purposes.

A THS auto-trim function is active during normal conditions (normal laws).

The THS can be manually trimmed via the pitch trim switches only on ground or in flight if the auto-trim function is lost.

Each elevator is operated by:

- One conventional servo-control actuator
- One Electro-Hydrostatic Actuator (EHA).

In normal flight condition:

- The servo-control actuator is in active mode
- The EHA is in the damping mode.

The EHA will be in active mode after a failure of the adjacent servo-control actuator.

In case of large deflection demands, the elevator servo-control actuators and EHAs are activated simultaneously (on-demand double pressurization).

If there is a failure of the servo-control actuator (computer or servo-control failure), the servo-control is no longer controlled and operates in soft damping mode.

Then the EHA will operate in active mode and actuate the elevator.

If there are multiple failures, both actuators operate in hard damping mode to damp the surface.

Note: on ground, with no hydraulic pressure applied, the hard damping mode performs the damping of the moving surfaces in case of strong wind gust.

Under an emergency configuration (e.g.: total engine flame out), the computers engaged on the actuator, control and apply a rate limit in order to reduce the EHA power consumption.

The THS actuator has two Electric Motor Control Units (EMCUs):

- One ECMU is active at a time
- The EMCUs switch over at every two flights or if there is a failure.

Each ECMU controls an electric motor.

In normal conditions:

- The ECMU1 receives Command (COM) and Monitor (MON) orders from the PRIM1 (P1) (SEC1 (S1) as a backup)
- The ECMU2 receives Command (COM) and Monitor (MON) orders from the PRIM3 (P3) (SEC3 (S3) as a backup)

The motor position control is performed by a digital control loop commanded by the PRIMs and SECs through an ECMU.

In specific condition, if the auto-trim function and THS are lost, the pitch trim is achieved with the pitch trim switches. The THS function is replaced by the elevators (called de-trim function).

Each SSU has an integrated solenoid. When the Autopilot (AP) is engaged, the solenoid is energized and increases the force needed to move the SSUs. Above a certain force applied on the SSU, the AP disengages.

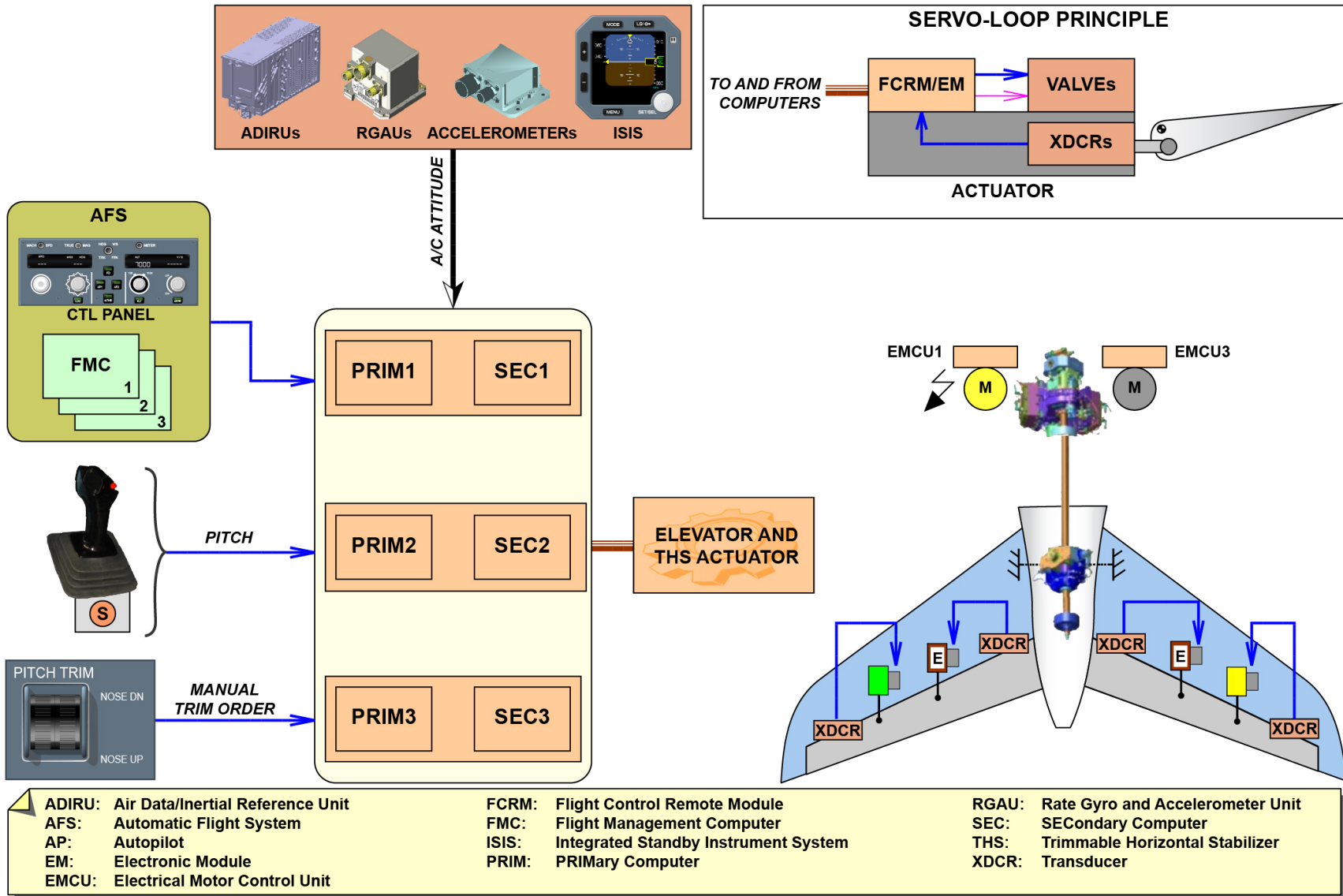

ACTUATORS GROUP VERTICAL FUNCTION: PITCH DESCRIPTION

V1813401 - V01T0M0 - VM27D5AGVER:3001



This Page Intentionally Left Blank

## PFCS VERTICAL FUNCTION DESCRIPTION (3)

### **Actuators Group Vertical Function: THS Actuator Description**

The THS actuator attachments to the A/C structure have a double load-path design:

- The primary load-path carries the load
- The secondary load-path remains free of any load.

If the primary load-path fails the secondary takes the load.

The THS actuator is made of a bi-directional no-back brake assembly that prevents back driving of the THS by the aerodynamic loads.

A dual motor actuator (called motor brake assembly) drives a screw jack based on command orders.

A ball nut assembly (moved by the screw jack) connects the THS actuator to the THS.

A fail safe (dual path with a tie rod) screw jack drives the ball nut assembly.

Mechanical stops are installed at the top and bottom of the screw jack.

A castle nut (bottom mechanical stop) is installed at the bottom of the screw jack.

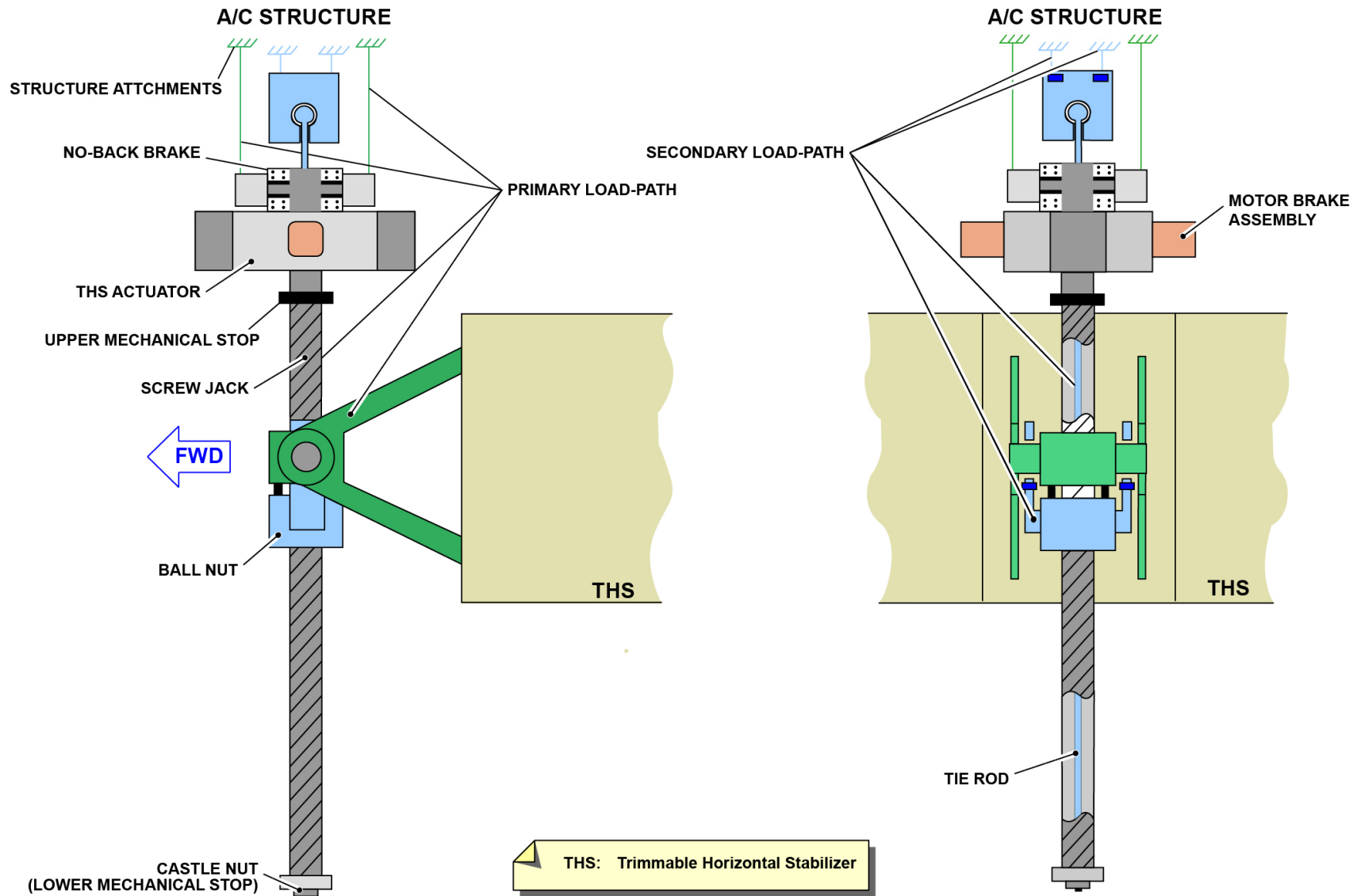

ACTUATORS GROUP VERTICAL FUNCTION: THS ACTUATOR DESCRIPTION

V1813401 - V01T0M0 - VM27D5AGVER3001

## PFCS VERTICAL FUNCTION DESCRIPTION (3)

### Actuators Group Vertical Function: THS Actuator Architecture

The THS actuator includes two EMCUs. Each EMCU has three physically and electrically segregated parts:

- COM channel
- MON channel
- High Power Electronics (HPE).

The function of the EMCU is to change digital data received from the PRIMs or SECs into command orders to drive the motor brake assembly. The EMCU also changes analog signals received from the position transducers into digital signals and send them back to the PRIMs and SECs.

The EMCUs receive power supply from the computers (60VDC).

One EMCU is in active mode and the other is in standby mode.

The active EMCU also receives power supply (230VAC through Remote Control Circuit Breaker (RCCB)), controlled by the computers, to energize the Motor Brake Assembly (MBA).

The HPE part of the EMCU acts as a transformer rectifier (from 3 phases 230VAC into 540VDC) to electrically energize the MBAs.

The COM and MON channels, both, incorporate redundant monitoring functions and ensure the feedback to the computers, including THS actuator position and THS actuator failure detection.

Only the COM channel controls its MBA.

Two MBAs are installed on the gearbox of the THS actuator. Each MBA has:

- One electrical motor (540VDC).
- One Power-Off Brake (POB) controlled by solenoids (two).

In normal condition, both POBs are released (solenoids energized). One energized solenoid per POB is needed to release its motor brake assembly. Each POB has a transducer that sends the POB status (applied or released) to its own EMCU (COM and MON channels).

Two Position Sensor Units (PSUs) measure the rotational movement of the gearbox and screw jack. Each PSU sends its data to one EMCU (to the both COM and MON channels).

The PSU1, related to the EMCU1 senses the screw jack movement and the PSU3 senses the gearbox movement. They monitor a possible gearbox mechanical failure, and send data to the computers.

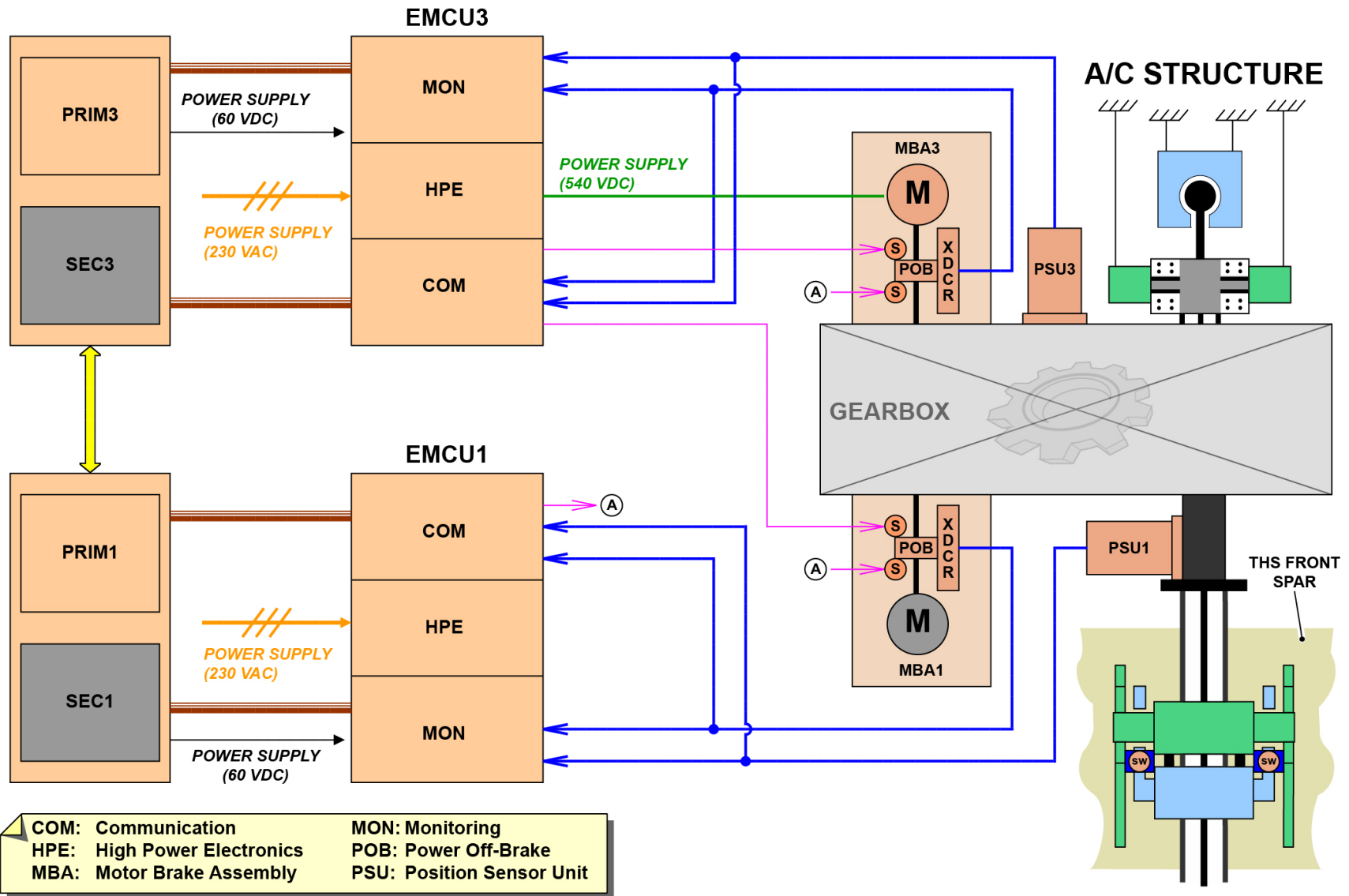

ACTUATORS GROUP VERTICAL FUNCTION: THS ACTUATOR ARCHITECTURE

V1813401 - V01T0M0 - VM27D5AGVER3001

## PFCS VERTICAL FUNCTION DESCRIPTION (3)

### **Actuators Group Vertical Function: THS Actuator Secondary Load-Path Detection Device**

The THS actuator is attached to the aircraft structure at its upper part and to the horizontal stabilizer at its lower part. These primary attachments take 100% of the structural load.

If there is a failure of a primary load-attachment structural, the secondary load-path takes over. This secondary load-path is installed at the upper and lower attachments and at the secondary nut yoke of the THS actuator.

The secondary load-path detection device detects:

- Any primary load-path component-failure
- An engagement of a secondary load-path.

This is done with load sensing pins. Each load sensing pin comprises two sensing elements (COM and MON) that are mechanically and electrically segregated.

Each sensing element output is processed by the channels of the EMCU (COM and MON) and transmitted to the computers. The confirmation of the load sensing pin engagement is done by the computers. If the load sensing pin is engaged, the computers will stop the THS actuator operation and the THS will remain at its last position.

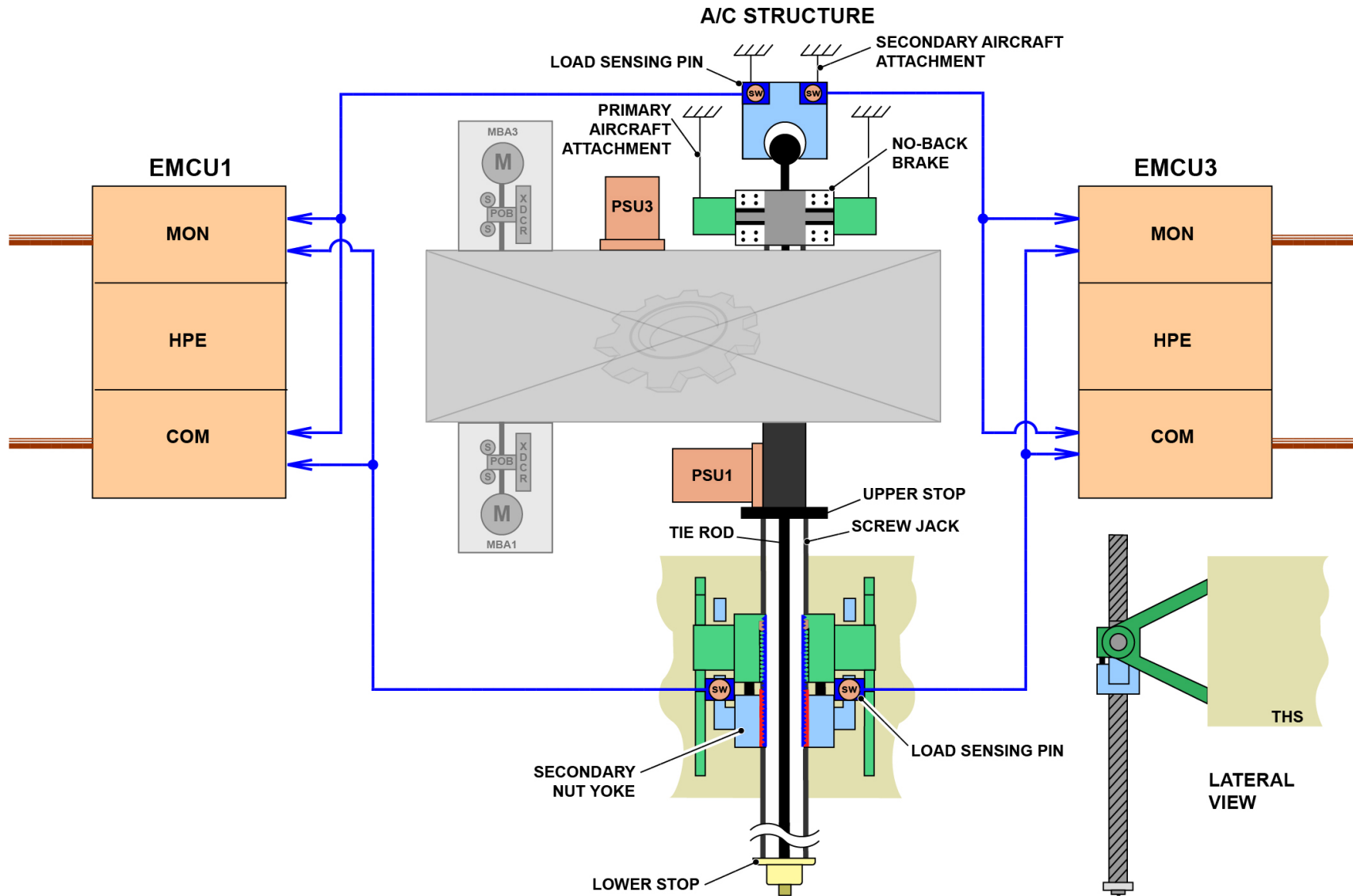

ACTUATORS GROUP VERTICAL FUNCTION: THS ACTUATOR SECONDARY LOAD-PATH DETECTION DEVICE

V1813401 - V01T0M0 - VM27D5AGVER3001

---

## PFCS VERTICAL FUNCTION DESCRIPTION (3)

### **Actuators Group Vertical Function: THS Actuator Components**

There are two inspection covers installed at each side of the no-back brake housing. These covers give access to the no-back brake compartment and its elements during periodic inspections while the THS actuator remains installed on the aircraft.

One no-back brake cover contains a sight glass with marked indications (minimum and maximum) indicating the oil level. A level below the minimum level is an indication to service the no-back brake with oil. In order to perform an inspection of the no-back brake, the oil must be drained through the drain plug.

The gearbox is lubricated only by approved grease.



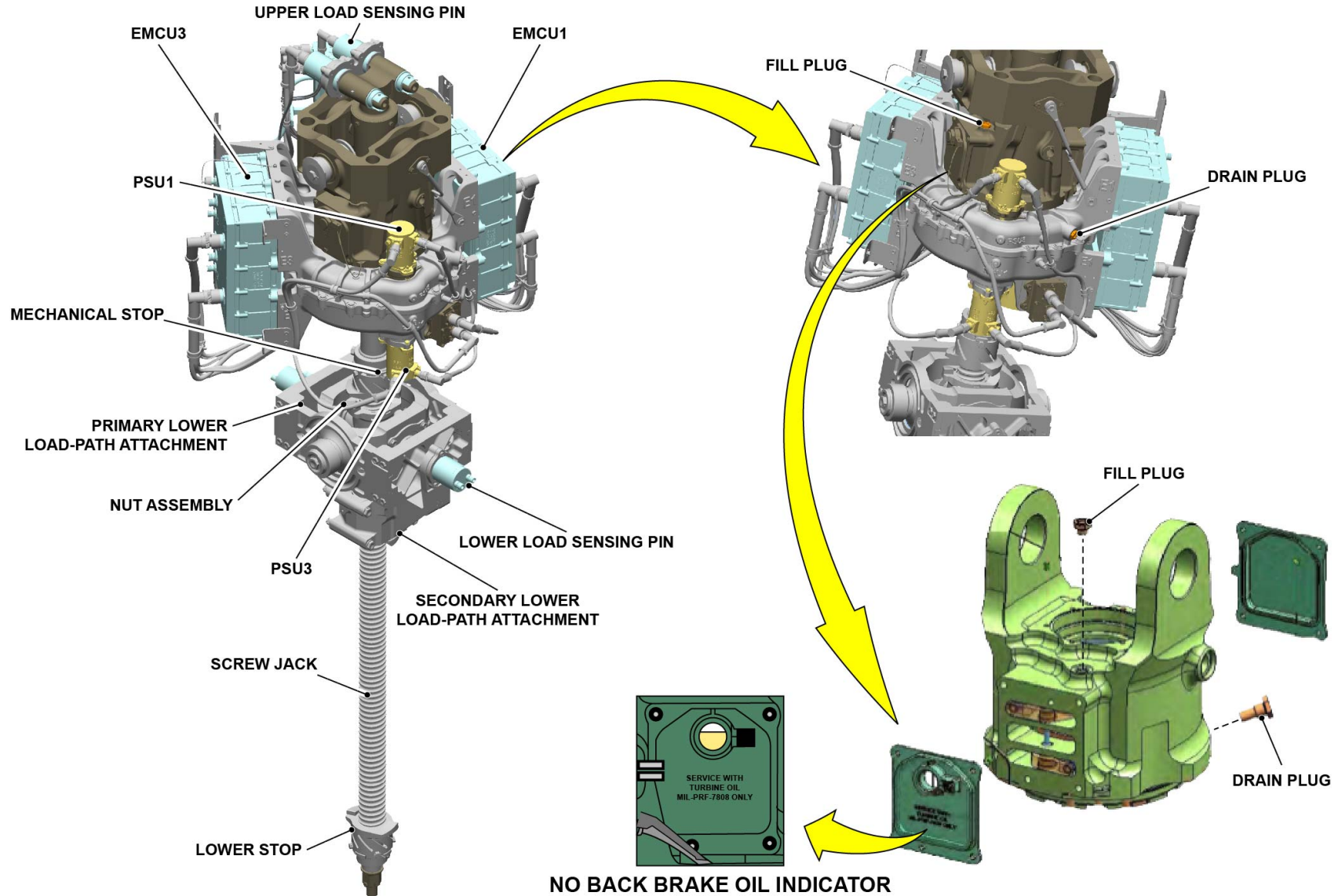

ACTUATORS GROUP VERTICAL FUNCTION: THS ACTUATOR COMPONENTS

V1813401 - V01T0M0 - VM27D5AGVER3001

## **SPEED BRAKES AND GROUND SPOILERS DESCRIPTION (3)**

### **Description**

The spoilers are used to decrease the speed (speed brake) and to dump lift on ground (ground spoilers).

All the spoilers (1 to 7) are used for the speed brake function.

With all the spoilers (1 to 7), all the ailerons are used for the lift dumping function (ground spoilers).

The PRIMary Computers (PRIMs) and SECondary Computers (SECs) receive command control inputs from the speed brake lever. The thrust levers and thrust reverser levers position is also necessary for the computation of the spoiler deflection logic.

The PRIMs and SECs also receive data from the Radio Altimeters (RAs) and LGERS to compute the air/ground status.

For computation of the spoiler extension in flight, the PRIMs and SECs receive A/C attitude data (Air Data/Inertial Reference System (ADIRS), Rate Gyro and Accelerometer Units (RGAUs)).

As the flaps are designed as adaptive droop hinge flaps and to increase the aerodynamic efficiency, the spoiler droop function reduces the gap between the spoilers and the flaps when the flaps are extended (the position 0 of the spoilers is no longer a mechanical stop).

The spoiler command orders from the PRIMs or SECs move the spoiler down or up in relation to the flap position. The flaps position is given by the Slat Flap Control Computers (SFCCs).

The structural panels between the fuselage and the spoiler 1 are mechanically connected to the inboard flap panel. They follow the inboard flap movement with a mechanical linkage.

For the roll command orders, the deflection is done in relation to the flaps position and A/C speed.

During flight with the flaps extended, if a spoiler is deflected for the roll function or the speed brake function, the spoiler angle of deflection is the sum of the spoiler droop angle value and the roll calculated deflection or the selected speed brake extension.

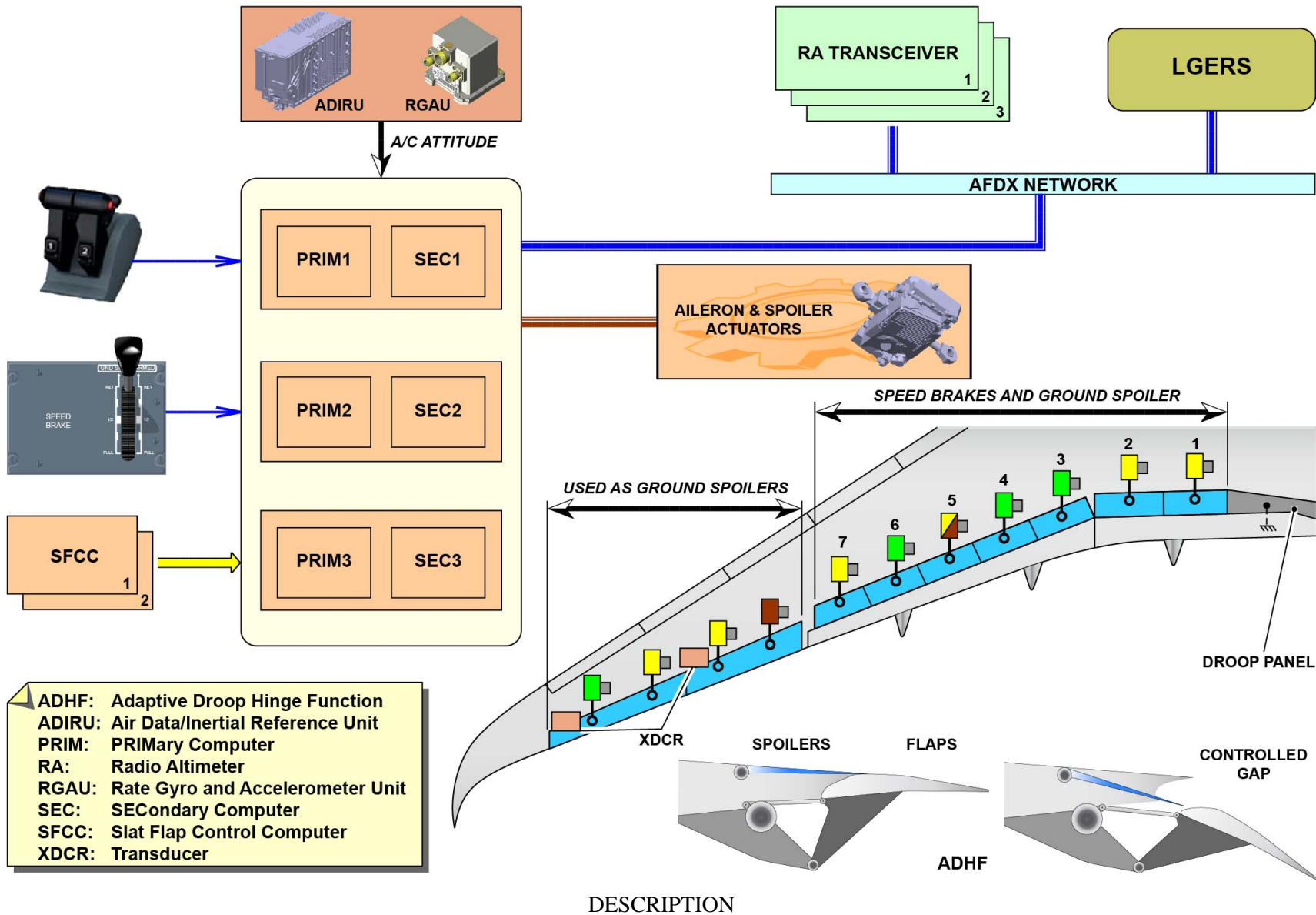

V1813401 - V01T0M0 - VM27D6AGSBR3001

## **SPEED BRAKES AND GROUND SPOILERS DESCRIPTION (3)**

### **Ground Spoiler Actuation**

The speed brakes are automatically retracted if the thrust levers are applied above Maximum Continuous Thrust (MCT) or if the stall protection is activated. To reset this automatic retraction spoiler, the speed brake lever must be put back to zero.

The speed brake is active in flight when the speed brake lever is used

The spoiler deflection angles are based on:

- The lever position
- The A/C speed (given by the ADIRS)
- The flaps position (given by the SFCCs).

To activate the ground spoiler function, the two conditions that follow are necessary:

- Pre-selection of the ground spoilers
- Ground condition.

The pre-selection is done:

- When the speed brake lever is in the ground spoiler armed position.
- Through an aft movement of the speed brake lever (more than 5 degrees) with the two engine thrust levers at idle.
- When the two engine thrust levers are at the idle position and one thrust reverser lever is moved.

The ground condition is confirmed when:

- The landing gears (2 as a minimum) are compressed with  $RA < 6$  ft or
- Only the wheel speed is above 72 knots, if the RAs do not operate.

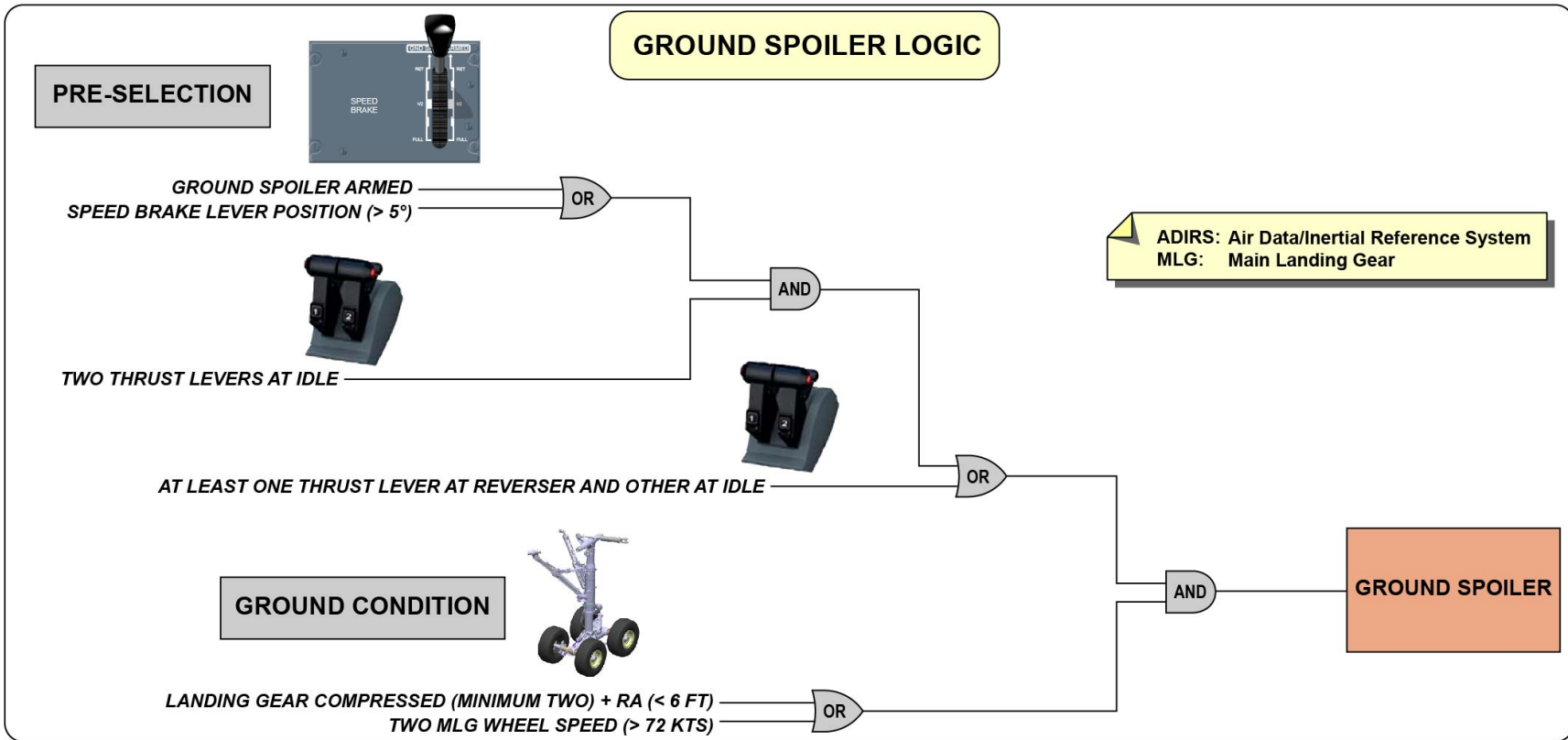
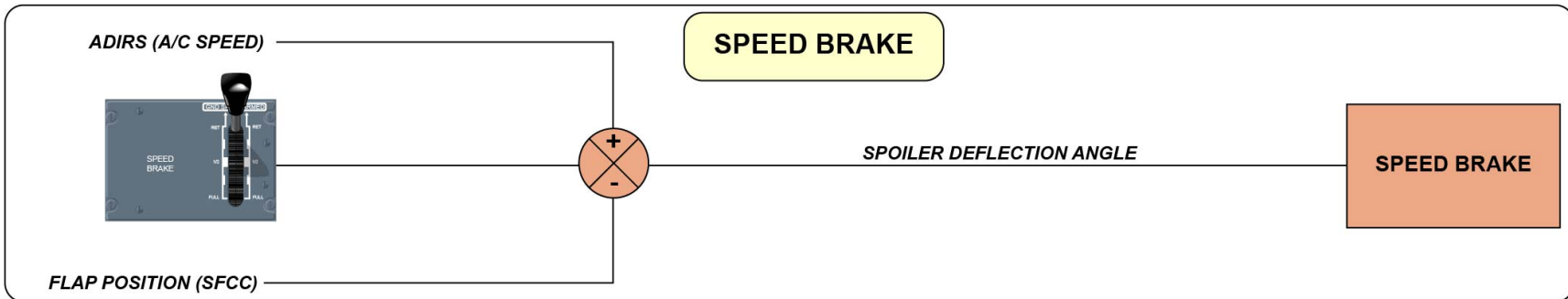

GROUND SPOILER ACTUATION

V1813401 - V01T0M0 - VM27D6AGSBR3001

## SPEED BRAKES AND GROUND SPOILERS DESCRIPTION (3)

### Spoiler Servo-control

The spoiler servo-control actuator has a Flight Control Remote Module (FCRM) and a body with an actuator. A hybrid servo-valve and a solenoid valve are installed on the body.

The FCRM has two physically and electrically segregated units (electrically supplied by the PRIMs or SECs):

- The Command (COM) unit
- The Monitoring (MON) unit.

The FCRM receives digital commands from the PRIMs or SECs and sends analog signals to the hybrid servo-valve and discrete signals to the solenoid valve.

The hybrid servo-valve sends hydraulic power to extend or retract chamber.

The solenoid valve (if energized) configures the servo-control actuator in the active or anti-extension mode, operating on a mode valve and a primary anti-extension valve.

The FCRM uses the pressure and position transducers for the servo-loop function (feedback).

The spoiler servo-controls have three modes of operation:

- The active mode, to move the spoiler surface up or down
- The anti-extension mode (in case of failure), to enable a free spoiler retraction by aerodynamic loads and prevent free floating
- The maintenance mode, to allow free spoiler movement for maintenance purposes.

The anti-extension relief valve is used if there is a loss of spoiler control or hydraulic system:

- To prevent the spoiler extension under aerodynamic loads
- To enable the spoiler retraction under aerodynamic loads
- To enable the flap retraction when the spoiler is in down position.

The anti-extension relief valve is also used in the maintenance mode to enable fluid circulation between the chambers. The maintenance mode is activated with a special tool engaged in a maintenance key slot.

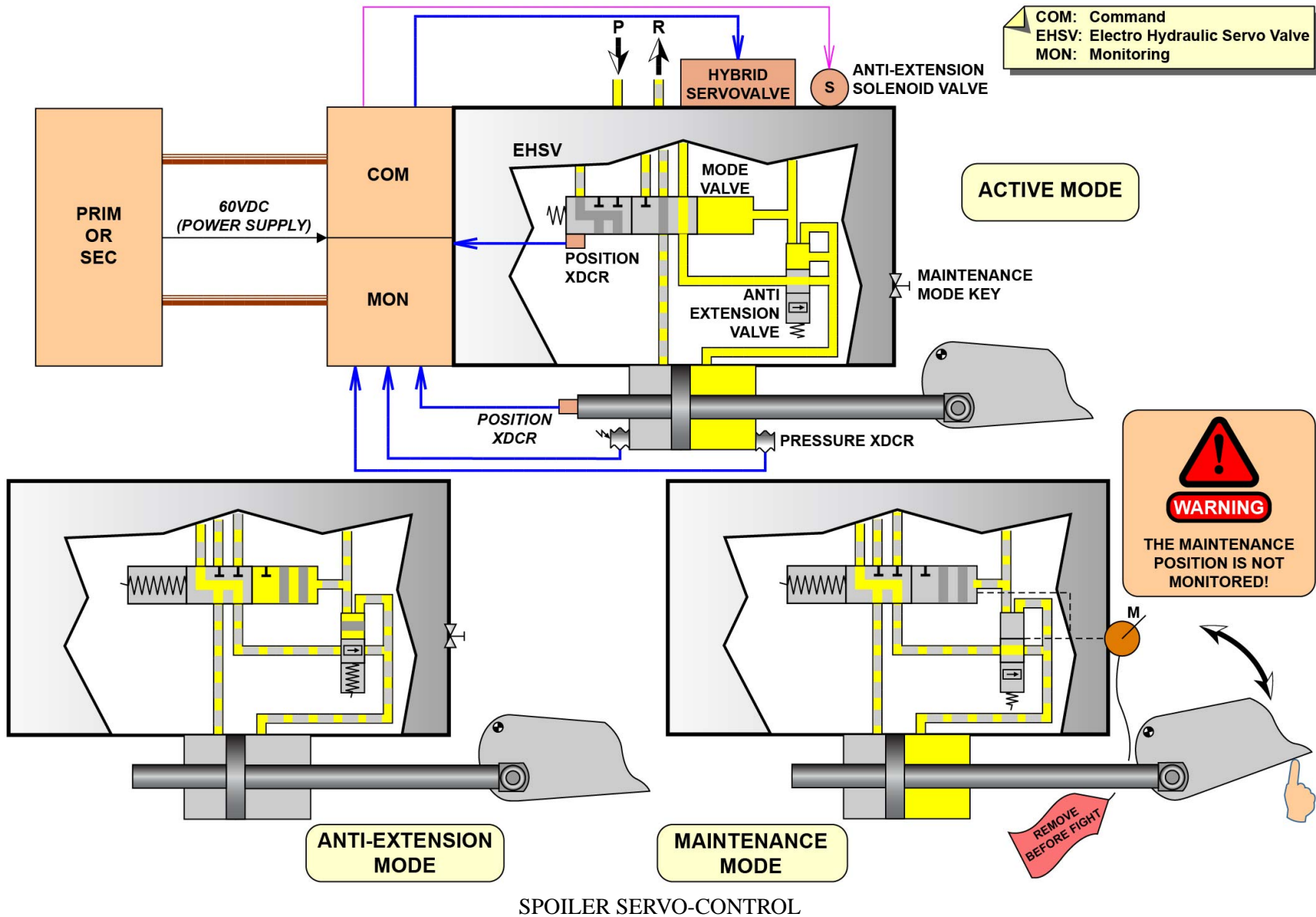

V1813401 - V01T0M0 - VM27D6AGSBR3001

---

## SPEED BRAKES AND GROUND SPOILERS DESCRIPTION (3)

### **Spoiler Servo-control components**

The spoiler servo-control is composed of different components such as:

- FCRM
- Electro Hydraulic Servo Valve (EHSV)
- Anti extension valve
- Etc.

A maintenance key (tool to be engaged in a slot), if activated, keeps the actuator in the maintenance mode. The maintenance mode is not monitored by the PRIMs or SECs.

To prevent the dispatch of the actuator in the maintenance mode, make sure that you can see the installed flag or streamer.



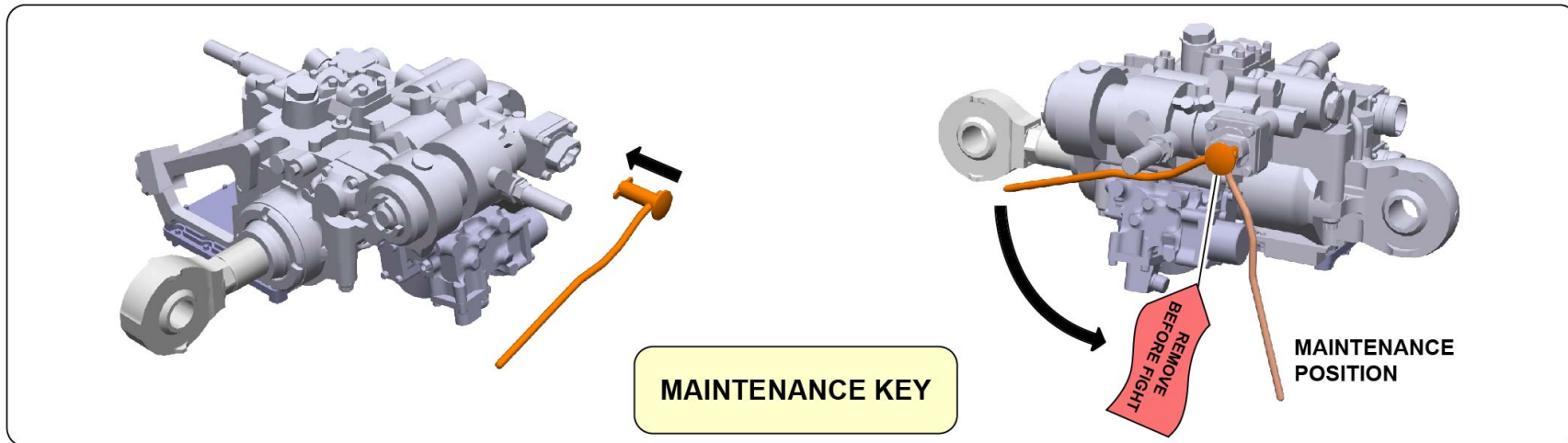
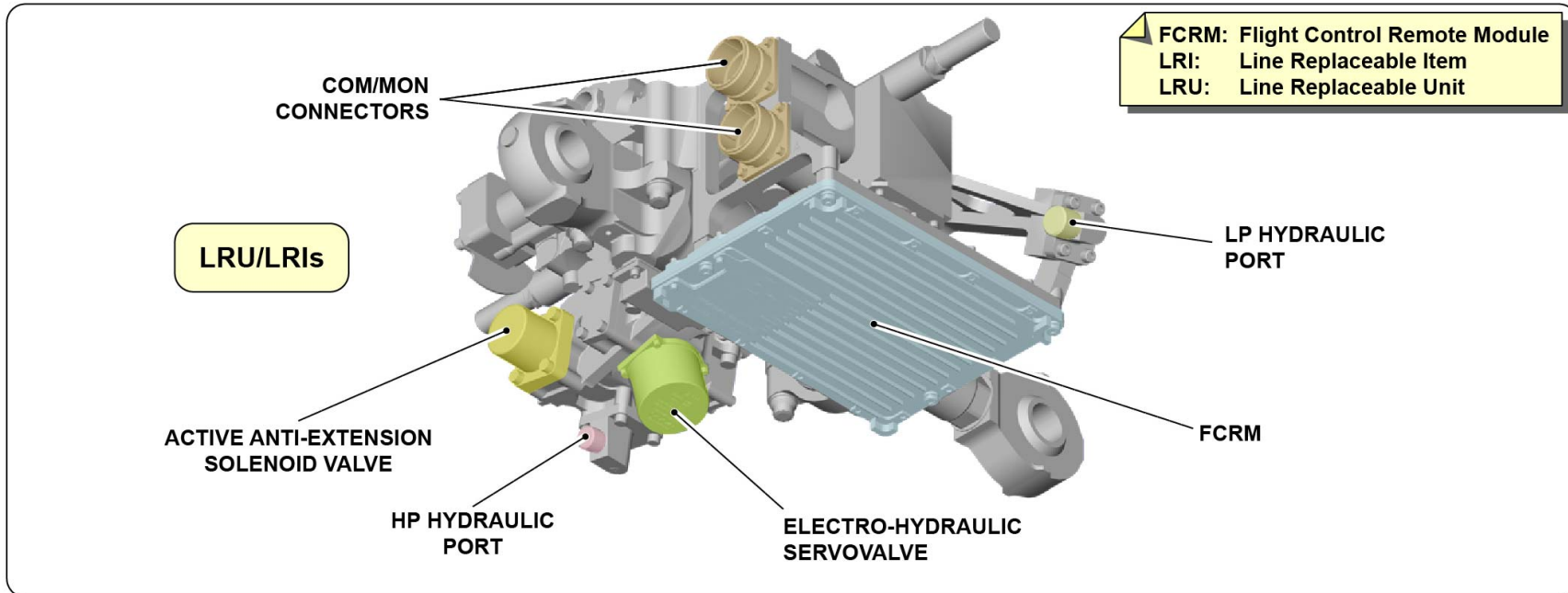

SPOILER SERVO-CONTROL COMPONENTS

V1813401 - V01T0M0 - VM27D6AGSBR3001

## **SPEED BRAKES AND GROUND SPOILERS DESCRIPTION (3)**

### **Spoiler Electrical Backup Hydraulic Actuator (EBHA)**

An EBHA is a servo-control actuator and an Electro-Hydrostatic Actuator (EHA) assembled in one block. It has an electronic module with two units (COM and MON). They are electrically supplied by the computers. The function of the unit is the same as a FCRM: to exchange data with the computers.

The electronic module has also a third unit: the power electronic unit, which is physically and electrically segregated from the rest. This unit receives power supply (230VAC) from the PRIMs or the SECs.

The EBHA uses hydraulic or electric power. If the hydraulic pressure is available, the hybrid servo-valve will use it to move the actuator piston. The hydraulic active/anti-extension solenoid valve is used to select the active or anti-extension mode.

A visual indicator is used to do a check and test of the EBHA on ground. If the hydraulic pressure is lost, the 230VAC power is changed to 540VDC and supplied to the motor-pump assembly. The electric active/anti-extension solenoid valve is used to select the electric active mode.

As there is no mechanical stops because of the positive and negative extension of the spoilers, the anti-extension mode keeps the spoilers in their rigged 0 position.

The piston chamber pressure-transducers and a piston position transducer are used to do the servo-loop. They electronically make sure that the command orders are correctly done.

The EBHA can be set to the maintenance mode. A maintenance key receptacle is used for the selection of the maintenance mode.

EM: Electronic Module

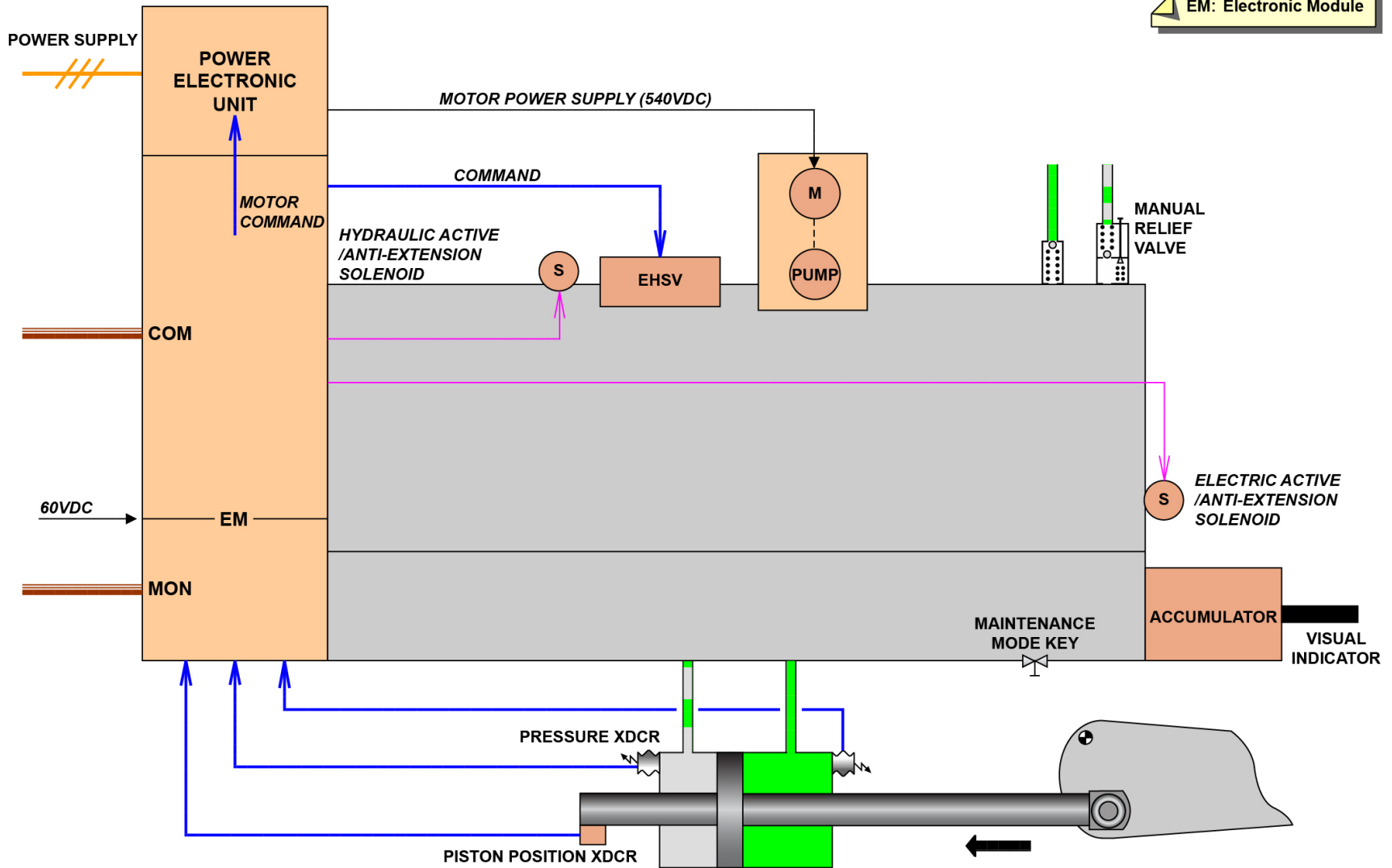

SPOILER ELECTRICAL BACKUP HYDRAULIC ACTUATOR (EBHA)

V1813401 - V01T0M0 - VM27D6AGSBR3001

---

## SPEED BRAKES AND GROUND SPOILERS DESCRIPTION (3)

### **EBHA Components**

The EBHA is composed of different components such as the electronic module, servo module, motor pump, solenoid valve, etc.

The EBHA has two different sides:

- A hydraulic side, which has all hydraulic components
- An electronic side, which is isolated from the hydraulic side.

The electronic module is installed in the electronic zone.

A manual discharger depressurizes the EBHA before the disconnection of the hydraulic lines.

The EBHA has a maintenance key (tool to be engaged in a slot). If it is activated, it keeps the actuator in the maintenance mode. When the EBHA is set to the maintenance mode, it is not monitored by the PRIMs or SECs.

To prevent a dispatch of the actuator in the maintenance mode, make sure that you can see the installed flag or streamer.

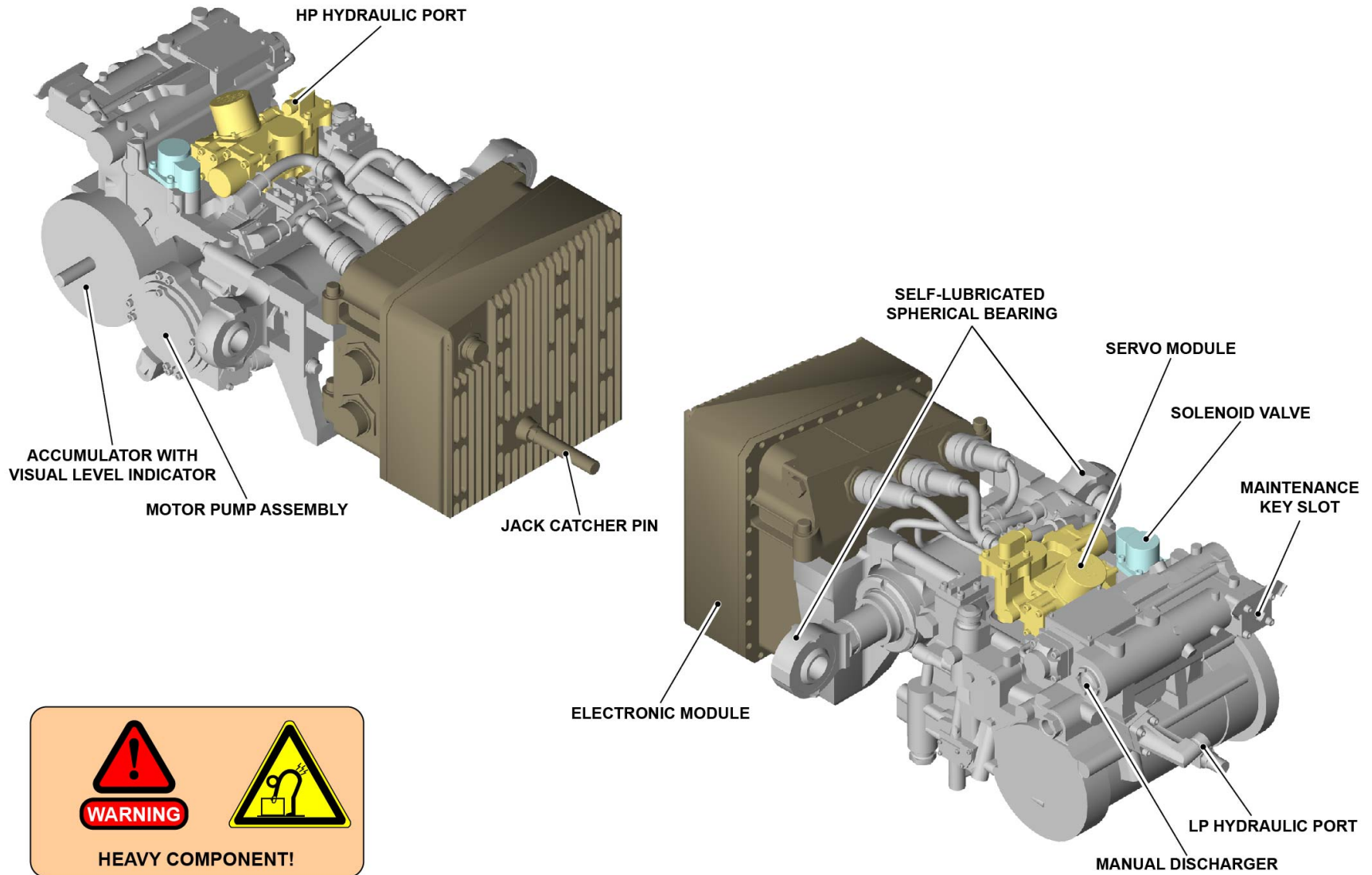

EBHA COMPONENTS

V1813401 - V01T0M0 - VM27D6AGSBR3001

## PFCS BACKUP SYSTEM DESCRIPTION (3)

### Backup-System Computer Description

If there is a permanent or transient loss of all PRIMary Computers (PRIMs) and SECondary Computers (SECs), a backup system which has a Backup Control Module (BCM) and a Backup Power Supply (BPS) takes over.

The BPS changes the yellow HP hydraulic power into electrical power.

The BPS electrical power supplies the BCM.

The BPS automatically starts to operate when the yellow hydraulic system is pressurized and if there is no (inhibition) signal from PRIM2 and SEC2.

The BCM automatically starts to operate when it is electrically energized by the BPS and if there is no (inhibition) signal from PRIM1, PRIM3, SEC1 and SEC3.

The BCM only receives the control orders from the manual inputs:

- Side stick units
- Pedals
- Pitch trim switches.

The BCM has two internal gyrometers to measure pitch and yaw rate angles. These gyrometers give the attitude information necessary to compute command orders to the surfaces.

The BCM only computes direct laws, with a direct connection between the pilot inputs and the surfaces. The BCM provides the pitch and yaw damping functions.

The Flight Control Data Concentrator (FCDC) applications are used as an interface for the BCM indications (activation or fault) and for test purposes.

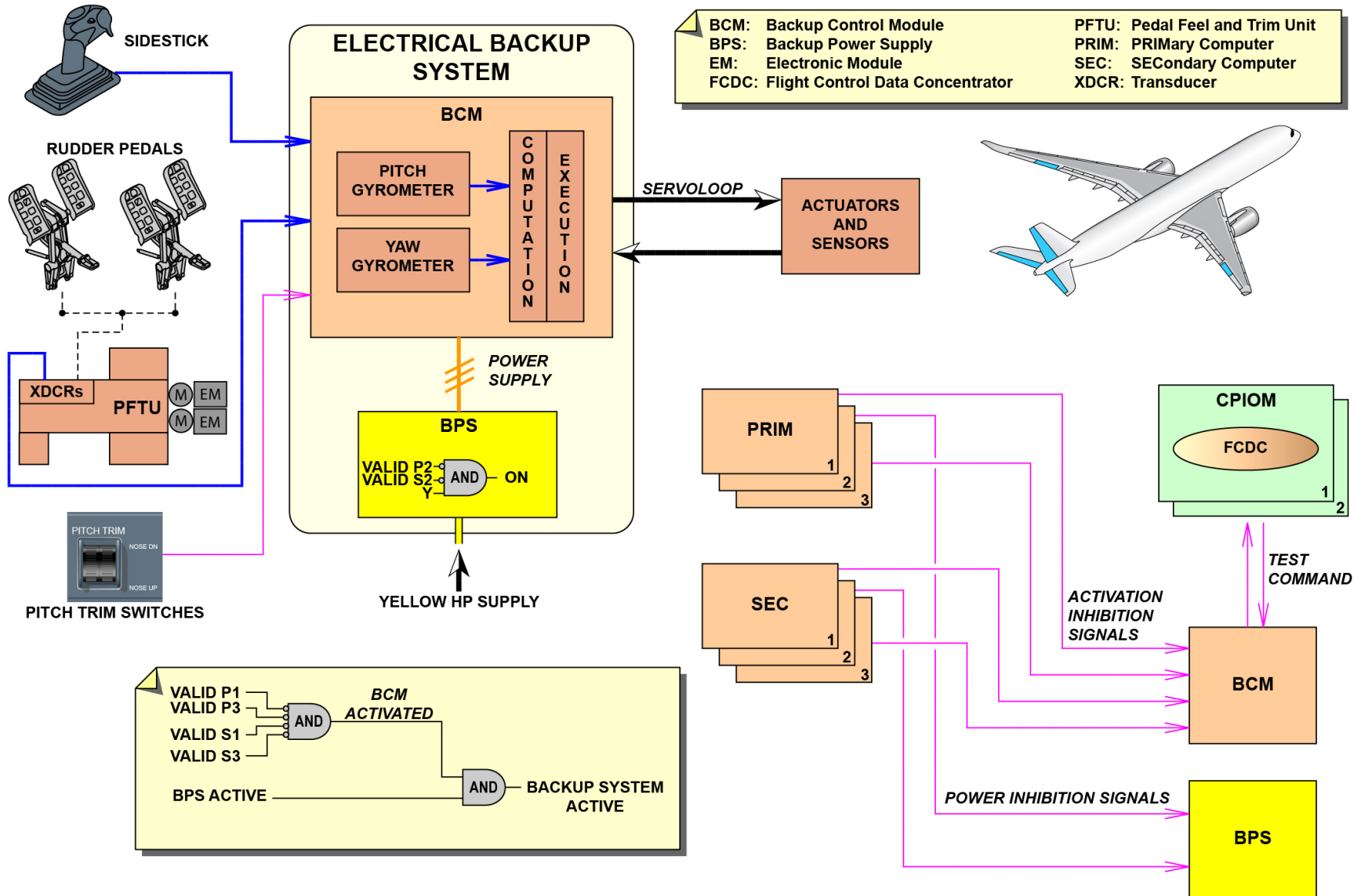

BACKUP-SYSTEM COMPUTER DESCRIPTION

V1813401 - V01T0M0 - VM27D7BACKP3001

---

## PFCS BACKUP SYSTEM DESCRIPTION (3)

### **Backup-System Actuation Description**

The BCM controls the A/C only with the servo-control actuators (Electro-Hydrostatic Actuator (EHA) and Electrical Backup Hydraulic Actuator (EBHA) are not used by the backup system).

The BCM sends command orders to:

- The two servo-control-actuators of the inboard aileron for the roll control
- The two servo-control-actuators of the elevator for the pitch control
- The upper servo-control-actuator for the yaw control.

These analog command signals are sent to the servo-control-actuators solenoid-valves and the hybrid servo-valve (hard-wired).

Some Rotary Variable Differential Transducers (RVDTs) send the surface position to the BCM to monitor the surface movement. The transducers are electrically supplied by the BCM. These signals are used to do the servo-loop function.



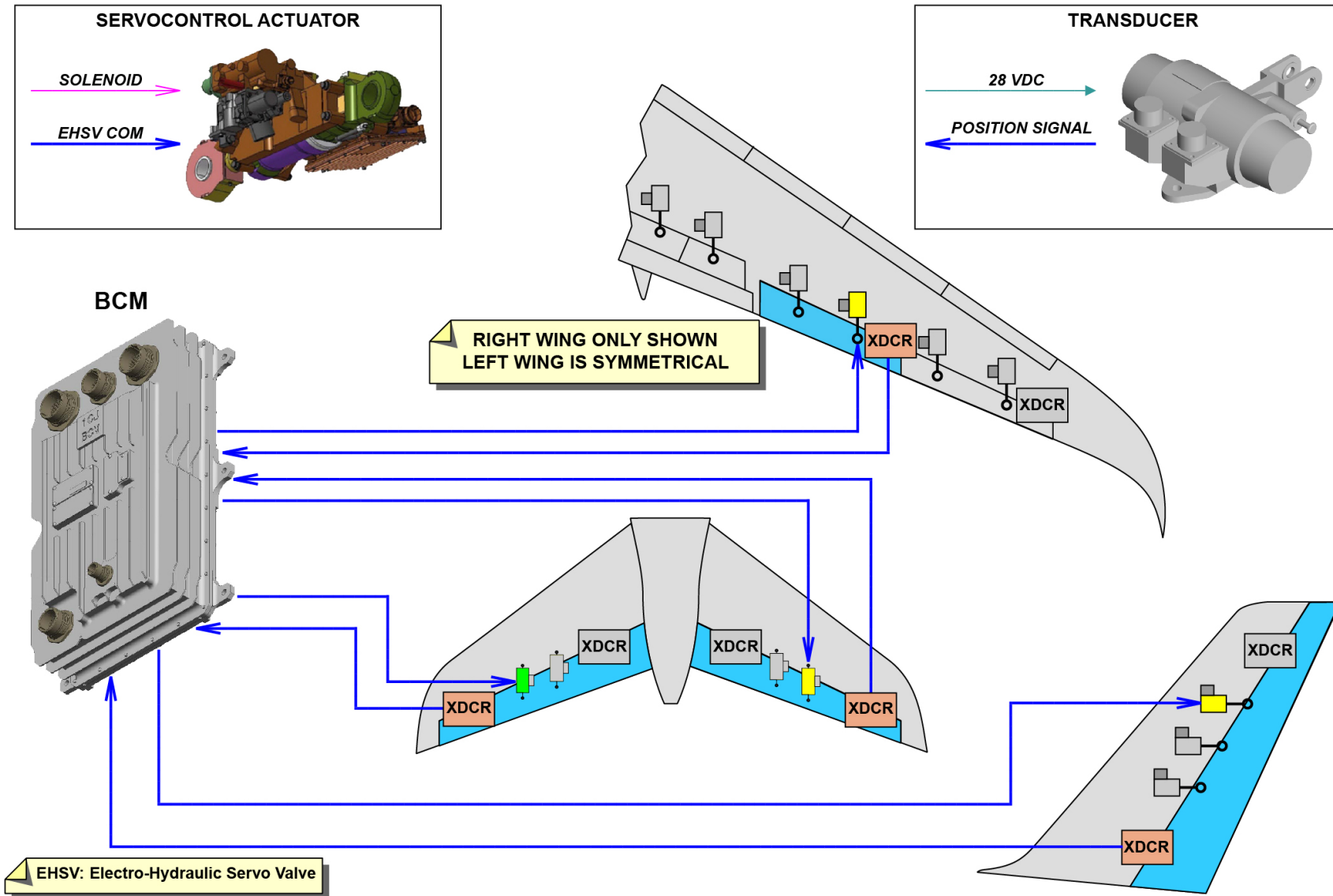

BACKUP-SYSTEM ACTUATION DESCRIPTION

V1813401 - V01T0M0 - VM27D7BACKP3001

---

## PFCS BACKUP SYSTEM DESCRIPTION (3)

### **Backup System Components**

The BCM is a Line Replaceable Unit (LRU).

The BPS is also a LRU with two hydraulic connections and two electrical connectors.

Each servo-control actuator has a specific connector for backup system function.

The BCM is in the forward cargo area and the BPS in the belly fairing.

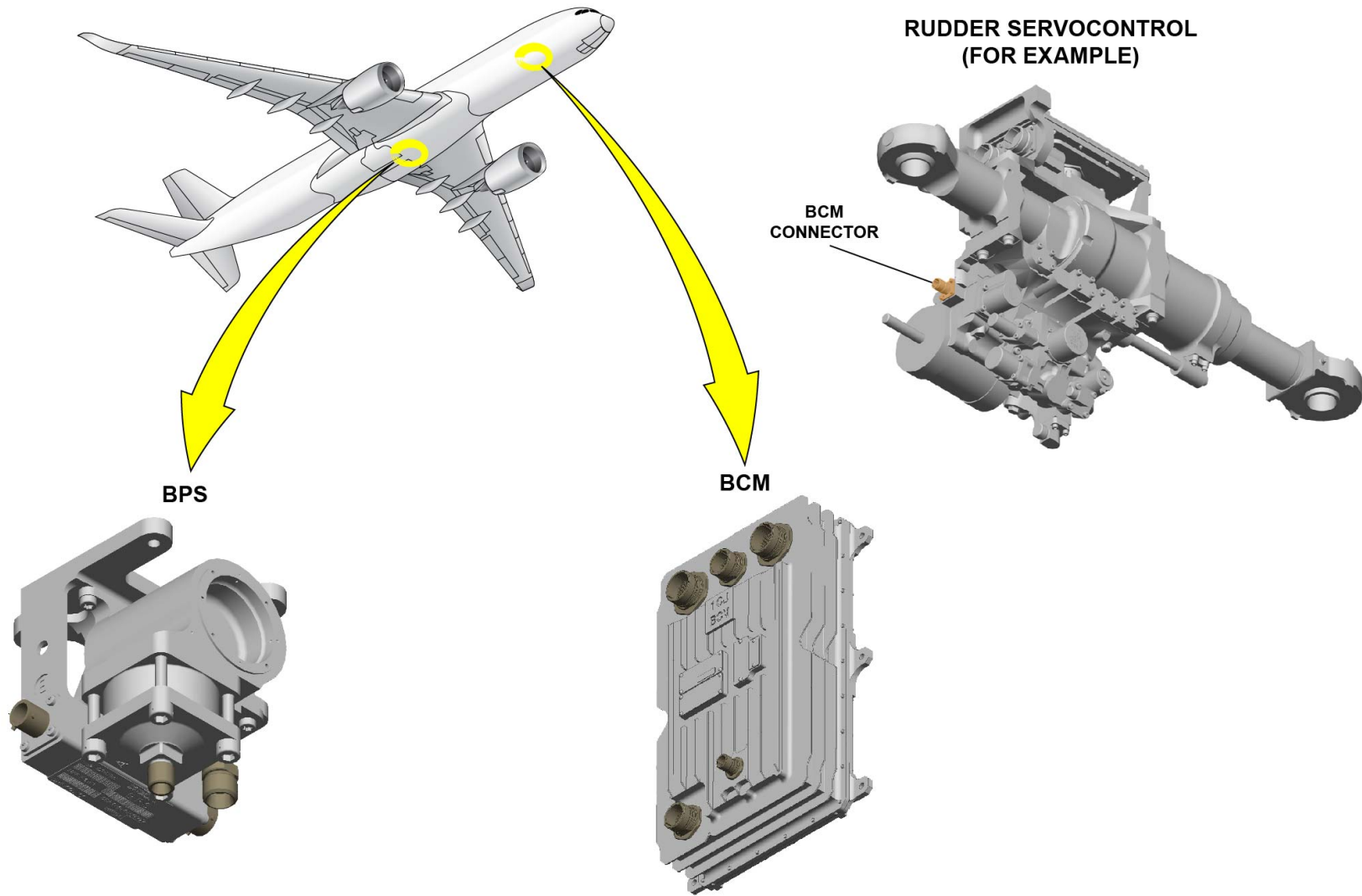

BACKUP SYSTEM COMPONENTS

V1813401 - V01T0M0 - VM27D7BACKP3001

## PRIMARY FLIGHT CONTROL SYSTEM (PFCS) CONTROL AND INDICATING (2/3)

### Primary Flight Control - General (2)

#### CONTROL INPUT

Flight Controls in the cockpit are divided on Control Inputs like:

- Sidesticks
- Chrono and Sidestick Priority
- Rudder Pedals
- Speed Brake Lever
- Pitch Trim Control Switches
- Rudder Trim Control

Also we found indication for F/CTL as:

- F/CTL Computers P/Bsw's
- F/CTL ECAM

#### F/CTL ECAM PAGE:

On the F/CTL page you will find all the indication concerning F/CTL, each surface is represented by a chart and near it, the concerning boxes for its actuators.

Rudder is represented by an horizontal chart and three associate boxes for the actuators. The text Rudder Trim will be found on the top on the rudder zone with the associated trim data.

(note: all the abnormal operation indication will be explained on level III)

THS is represented by a vertical line and a triangular index and its associated electrical motors power supply.

You will find also indications for elevators, ailerons, spoilers and its associated actuator power supply.

On the top left indication about the SFCC operative and on the top left the Computers availability

### Roll, Yaw and Pitch Control (2)

Commands Orders:

On Ground the computation is a Ground Direct LAW, when a Sidestick lateral or longitudinal input is sent, ailerons, elevators and spoilers will move accordingly. Rudder will be moved by Rudder Pedals.

Max deviation will be shown only on ground.

Spoilers Normal Extension:

If you extend spoilers you will see the extension on the F/CTL ECAM PAGE and on the lower PFD (SFLM) on both side Capt and F/O

Also during spoiler operation on ground you will see an horizontal line on the F/CTL ECAM PAGE showing that max roll control deviation the ground spoilers are armed.

If you armed ground spoilers you will see on the SFLM a blue triangle showing that the ground spoilers are armed.

### Yaw and Pitch Trim Control (2)

Pitch Trim:

Pitch Trim Switches are composed of two switches, and two indications one in F/CTL page and a second indication on lower PFD.

Pitch Trim Switches are divided in two, to avoid inadvertent operation and to allow manual control of the THS actuator via three positions: up, neutral, down.

Pitch Trim Switches can be operated during ground operations.

During Flight phases the Pitch Trim Control Switches are inhibited with or without AP mode engaged. Only in the following cases Pilot is able to operate the Pitch Trim:

- In case of loss of the auto trim law the THS is under total manual control.
- In case of reversion to direct law (loss of auto trim law) combined with the loss of THS, the Pitch Trim Control Switches allow to trim the A/C through the elevators. (De-trim Function)

The THS position can be seen by the Ground Engineers on the Slat/Flap/Trim zone (lower part of PFD) during Ground Operations and for Pilots during Ground Phases and Takeoff and Landing.

On ECAM F/CTL System the set angle of THS is shown always. The numerical value of pitch trim angle shall be written with values in the interval [-13.7; -0.8] with an accuracy of 0.1°.

#### Rudder Trim:

This consists in a rotary switch for manual command of the rudder together with an associated reset pushbutton.

In AP mode, the switch and the reset pushbutton are inhibited and have no effect.

In Manual mode and mainly for engine flame out or high cross winds landings:

- The rotary switch will command a 'slow' trim control as opposed to the 'fast' control that can be operated by the pilot via the pedals. This is intended to relieve the pilot's effort on the pedals. The switch will control two trim motors located in the PFTU via the SEC computers.
- The reset pushbutton allows to automatically re-centering the pedals neutral point to zero.

The corresponding display, located on the Slat/Flap/Trim zone (lower part of PFD), will always stabilize to reflect the neutral position of the pedals and not the position of the rudder itself.

The display appears when:

- Rudder trim switch or reset push-button is activated,
- on ground below 60kts if the rudder trim is not in neutral position,
- in flight in case of engine failure,
- in flight or on ground above 60kts if the rudder trim is above a given threshold

#### Roll Trim:

Roll trim is provided by the PRIM master.

The roll is corrected by a combination of aileron orders and outer Flap surface movement.

The PRIM is in charge of sending trim orders command to ailerons and asymmetric order to the SFCCs for moving the outer flaps.

For example, a delta of 5° on ailerons and a delta of 1° on outer flaps provide the same roll correction, but a delta of 1° on outer flaps gives less drag

No indication or control for roll trim is available; this lateral trim control is performed always if Computers are available.

### **Sidestick Priority Annunciators (2)**

#### **PRIORITY ANNUNCIATORS**

In case of DUAL INPUT activation, indications to the Flight Crew are shown as follows with associated aural warnings.

If after a DUAL INPUT activation the priority PB is pressed, Priority will go to the last pressed sidestick PB with associated indications.

### **Computers Reconfiguration (3)**

PRIM and SEC pushbutton switches are on the FCTL integrated control panel 211VM and 212VM. There are six pushbutton one for each computer; 3PRIM and 3 SEC. Each PBs has two legends, (FAULT and OFF)

If one computer faults, the FAULT legend of the related pushbutton switch (Pushed In) comes ON.

If the PBs is released the OFF legend comes on and FAULT legend goes off.

If the PBs is pushed the OFF legend goes off and FAULT legend comes on again if a fault is still active.

Each actuator can be controlled by a pair of computers eg. PRIM 1 / SEC 1, in case of PRIM 1 loss, SEC 1 will take control of associated actuators.

### **Hydraulic Failure Reconfiguration (3)**

This airplane has three different types of Actuators for flight controls, Servocontrols, EHA and EBHA. In case of both Hydraulic system failures this Airplane is designed to control three axis by the electrical power supplied to EHA and EBHA (spoilers number 5).

For outboard ailerons the surface control will be done on dual actuation mode with force fighting monitoring and each actuator can be in three different modes active, soft damping and hard damping.

If we lost yellow hydraulic system, we will have single actuation, with the green servocontrol, remaining the yellow servocontrol in soft damping mode.

If we lost green hydraulic system, we will have single actuation with the yellow servocontrol.

If we lost both hydraulic system, both servocontrol will be in hard damping mode.

For inboard aileron, the surface will be commanded in single actuation, the yellow servocontrol will be in active mode while the EHA is in damping mode (only one damping mode)

If we lost yellow hydraulic system, we will move the surface with the EHA remaining the yellow servocontrol in damping mode

For Spoilers, each spoiler is moved by one actuator, and spoiler number 5 is moved by EBHA:

If we lost yellow hydraulic system, we will stop the spoilers number 1, 2 and 7 both sides. While spoiler number 5 will be driven by the electrical power supplied to EBHA.

If we lost green hydraulic system, we will stop the spoilers number 3, 4 and 6, both sides.

If we lost both hydraulic system, only spoiler number 5 will be able to move by the electrical backup on the EBHA.

For Rudder, the normal way of actuation is with both servocontrols on load sharing, if we lose one servocontrol you will activate the EHA and both conventional servocontrols will become damping

If we lost yellow hydraulic system or green hydraulic system, both servocontrols will become hard damping during cruise or soft damping during approach. The EHA become active commanded by the PRIM 2 computer.

If we lost both hydraulic systems at the same time, the same will happen. In case of single hydraulic system failure and after reconfiguration to EHA if we lost the EHA, we can reconfigure the rudder to the remaining servocontrol on the remaining hydraulic system.

For Elevators, in nominal flight conditions, the hydraulic actuator will be activated in priority, the electrical actuator will be activated after

failure. EHA may be activated on demand if high loads are expected on the Servocontrol.

If we lost yellow hydraulic system, we will move the R/H elevator with its EHA.

If we lost the green hydraulic system, we will move the L/H elevator with its EHA.

Both elevators will be moved by its own EHA in case of loss of both hydraulic system..

### **Pitch Trim Actuators Failure (3)**

THSA is powered by two electrical motors (one on E1, one on E3 bus bar) and actuates the horizontal stabilizer through a gearbox that actuates a dual load path ball screw.

The position control of the motor is performed by a digital control loop commanded by the PFCS computers through two EMCU.

One motor is active; the other one is in standby mode. Priority between both motors is swapped at each flight cycle.

Position sensors on the THSA screw provide position feedback for the servo loop and for the THS position monitoring.

An electrical symbol on each square representing the status of the Electrical power supply of the

- not displayed IF status is "Not avail"
- In Amber in case of low voltage,
- In Green otherwise

In our example the motor 1 is with low voltage and it will be represented as an amber cross arrow

Motor 2 is faulty so it is represented with amber square.

### **Rudder Control Failure (3)**

The rudder is driven by two conventional servo-controls and one EHA. In normal operation, the 2 servo controls are active with load sharing function and the EHA is commanded in hard damping mode (cruise) / soft damping mode (approach / landing).

In case of loss of one servo control, the other S/C is switched to hard damping mode (cruise) / soft damping mode (approach / landing) and EHA is activated alone. If we are in single actuation under command of EHA in case of high hinge moment demand available S/C will be activated (double pressurization with no force fighting management).

If we are on EHA configuration and we loss the Electrical power or the EHA, we will jump to the single available Conventional Servocontrol.

For the failures configuration the damping modes are not represented in the ECAM page, however the status of the actuators is represented graphically either to show the availability of the power source or to represent the operational status of the actuator itself. When actuator is not available an amber box surround the power cross arrow.

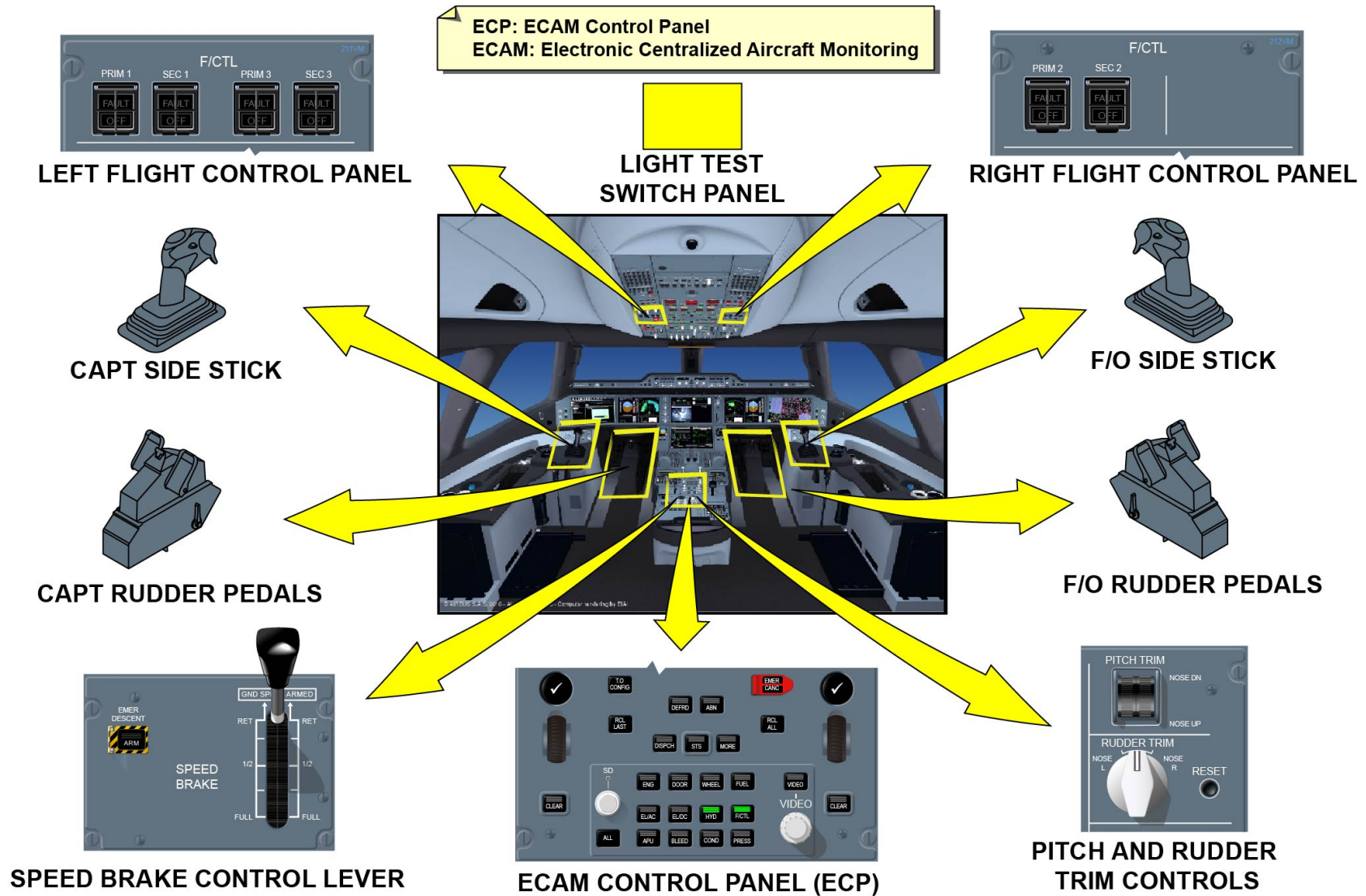

PRIMARY FLIGHT CONTROL - GENERAL (2) ... RUDDER CONTROL FAILURE (3)

V1813401 - V01T0M0 - VM2711PFC030001



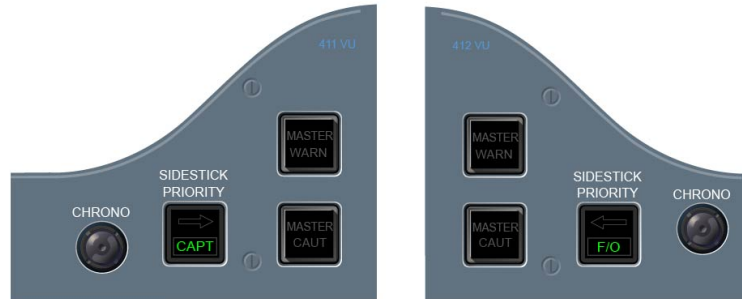

## DUAL INPUT

**DUAL INPUT INDICATION**  
WHEN BOTH PILOTS SEND SIDESTICK  
CONTROL ORDERS AT THE SAME TIME

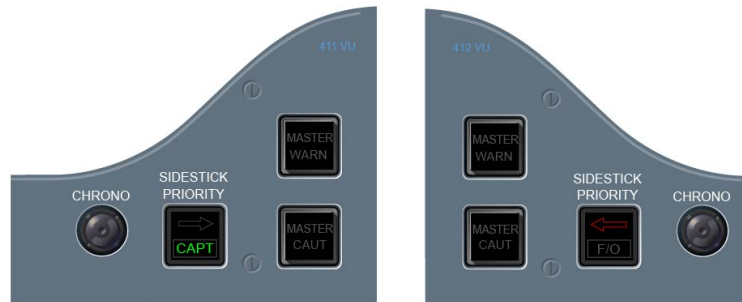

## PRIORITY LEFT

**PRIORITY LEFT INDICATION**  
WHEN THE CAPT PRESS THE PRIORITY P/B,  
THE F/O SIDESTICK IS INHIBITED



**ASSOCIATED COMPUTER IS ON**



**ASSOCIATED COMPUTER IS OFF**



**ASSOCIATED COMPUTER IS FAULTY (STEADY)  
OR FLASHING IF IS IN GROUND SAFETY TEST**



PRIMARY FLIGHT CONTROL - GENERAL (2) ... RUDDER CONTROL FAILURE (3)

V1813401 - V01T0M0 - VM271PFCS03001

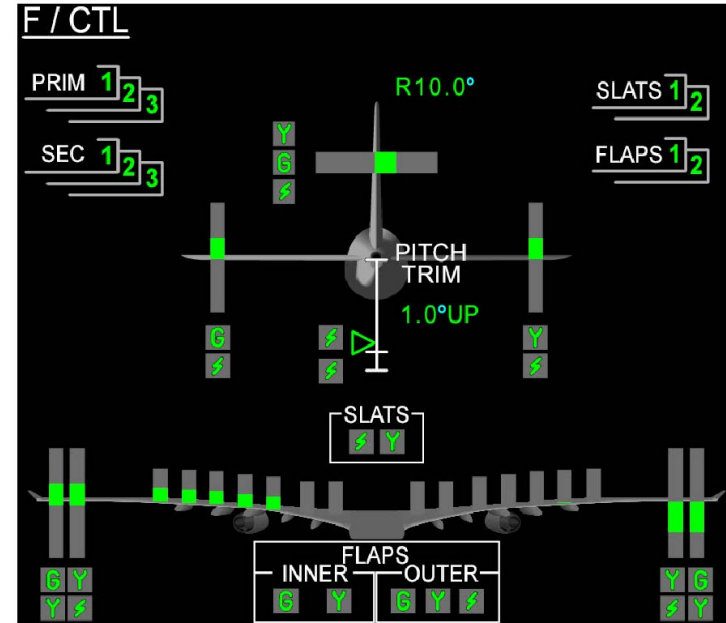
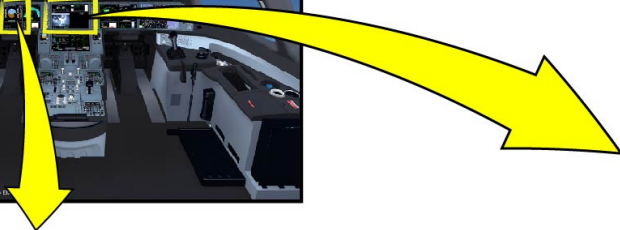

SD FLIGHT CONTROL PAGE



PFD NORMAL PAGE

SLAT FLAP LIMITATION MEMO

PRIMARY FLIGHT CONTROL - GENERAL (2) ... RUDDER CONTROL FAILURE (3)

V1813401 - V01T0M0 - VM2711PFC030001

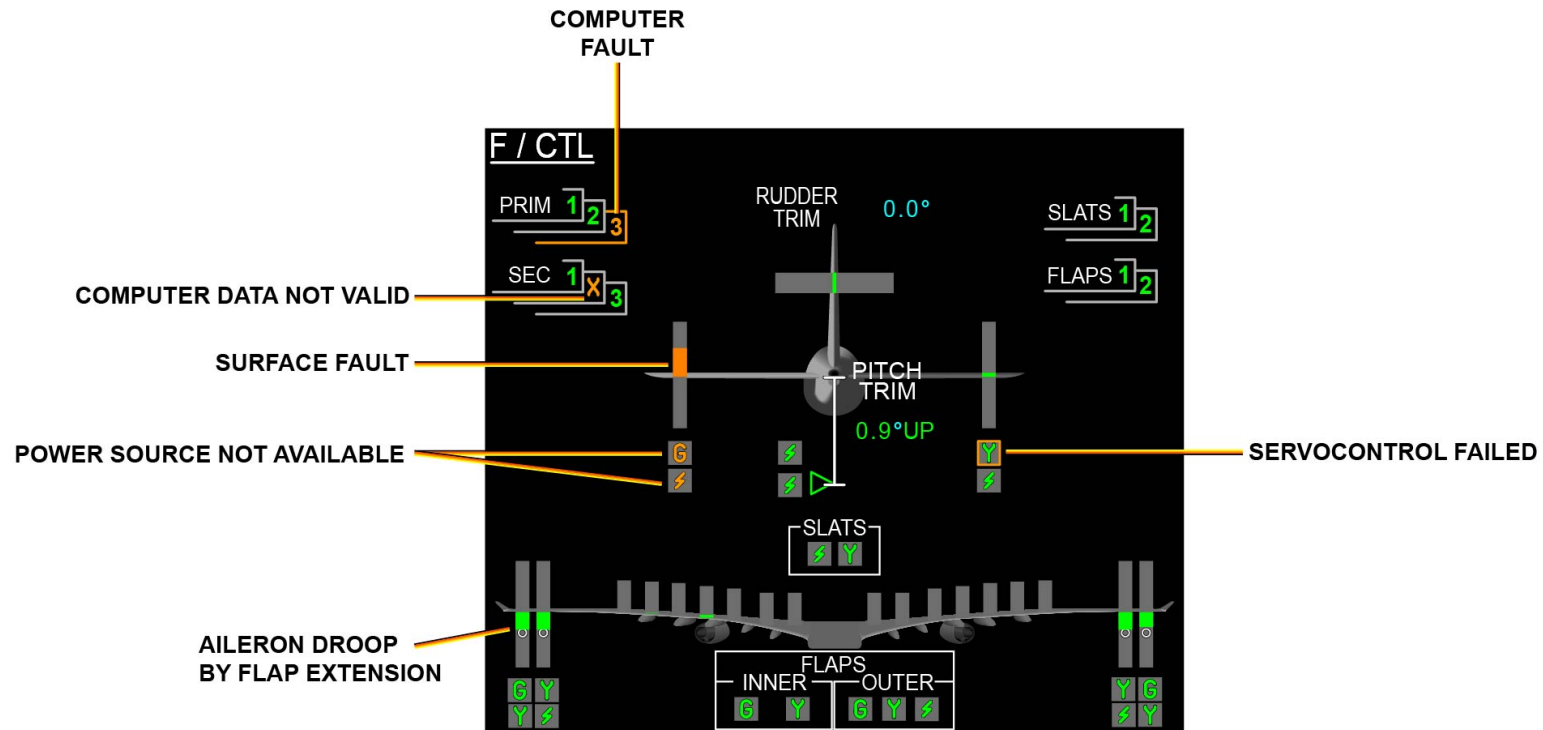

PRIMARY FLIGHT CONTROL - GENERAL (2) ... RUDDER CONTROL FAILURE (3)

V1813401 - V01T0M0 - VM2711PFC03001

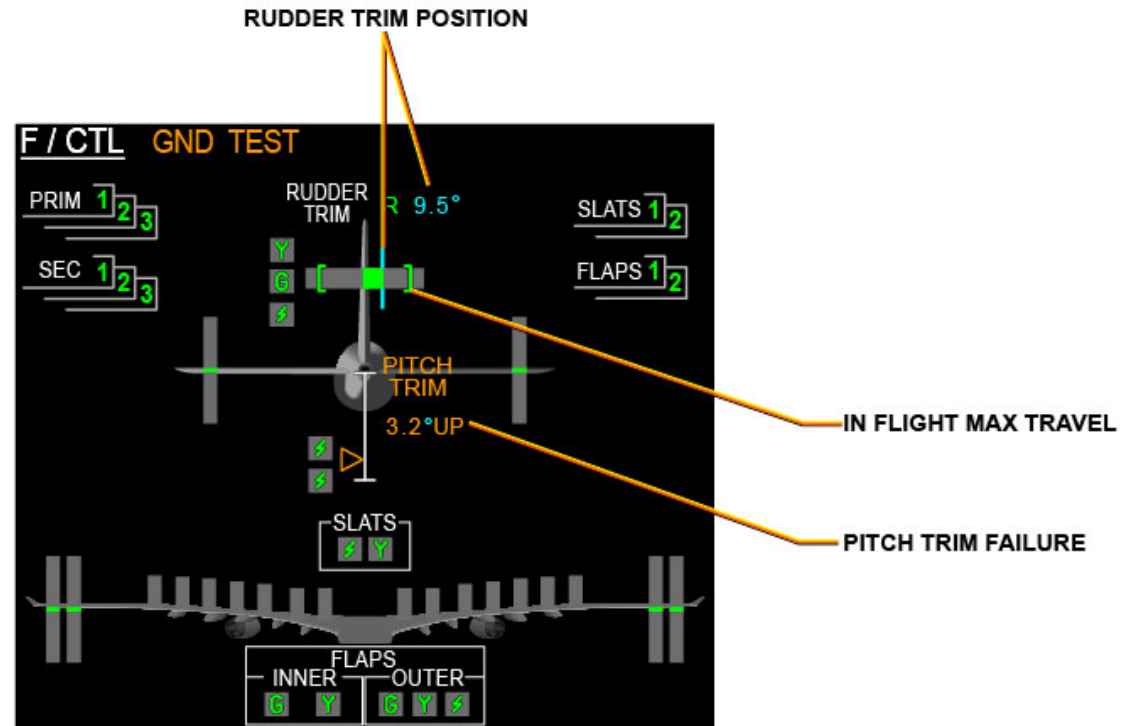

PRIMARY FLIGHT CONTROL - GENERAL (2) ... RUDDER CONTROL FAILURE (3)

V1813401 - V01T0M0 - VM271PFCS03001

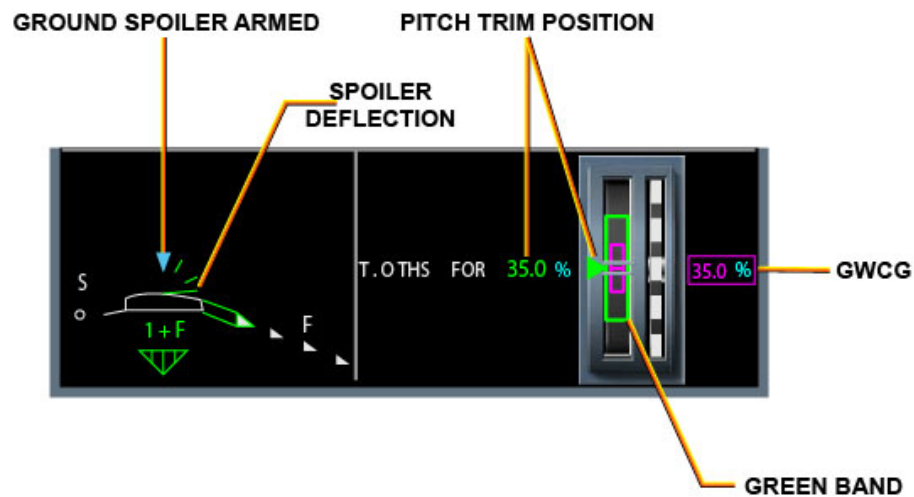

PRIMARY FLIGHT CONTROL - GENERAL (2) ... RUDDER CONTROL FAILURE (3)

V1813401 - V01T0M0 - VM271PFCS03001

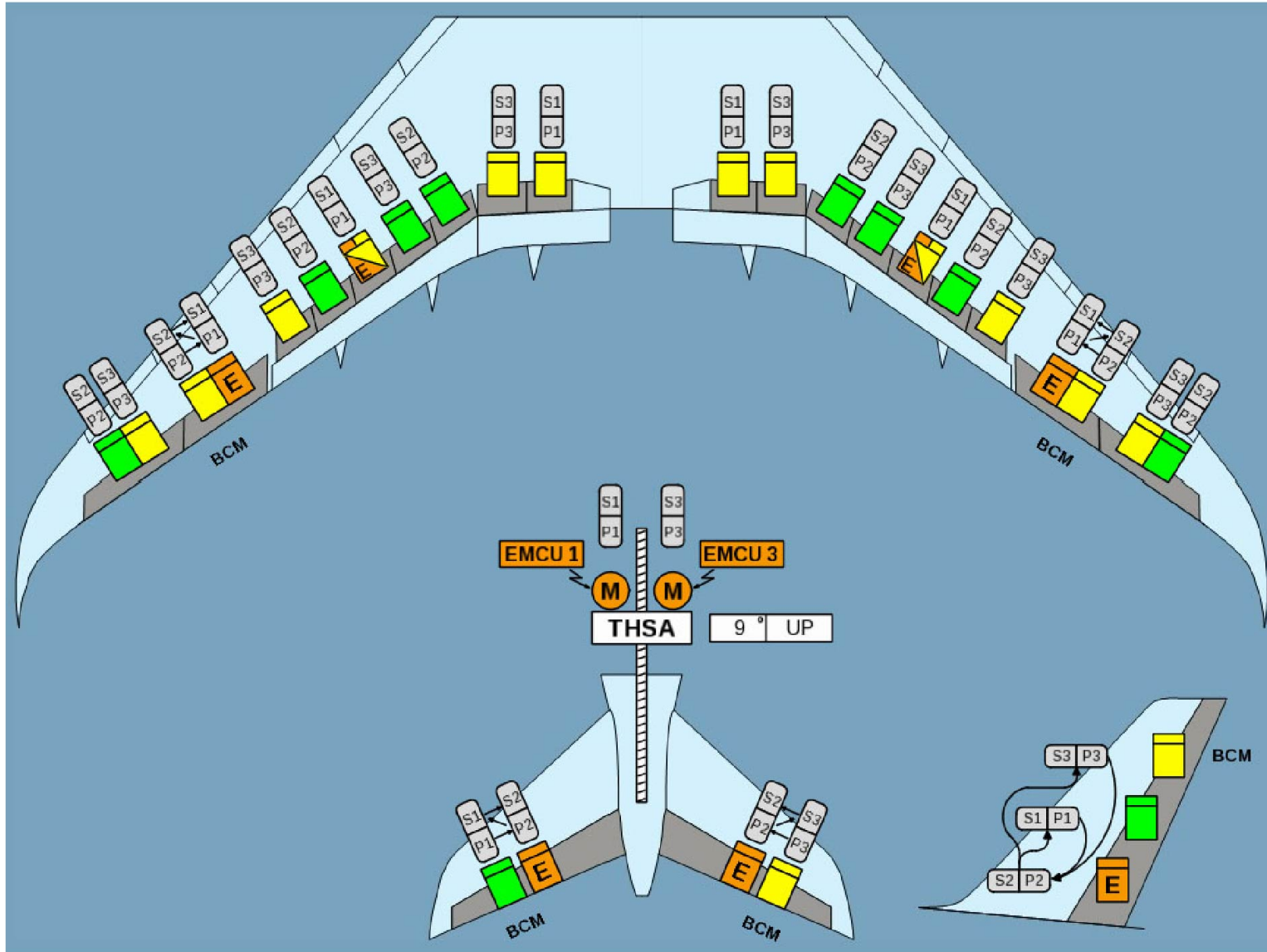

PRIMARY FLIGHT CONTROL - GENERAL (2) ... RUDDER CONTROL FAILURE (3)

V1813401 - V01T0M0 - VM2711PFC S03001

This Page Intentionally Left Blank

---

**PRIMARY FLIGHT CONTROL SYSTEM (PFCS) MAINTENANCE (2/3)****Spoiler: Special Tools**

A special spoiler collar for the servo-control and the Electrical Backup Hydraulic Actuator (EHBA), is needed to make the dispatch possible:

- Under the Master Minimum Equipment List (MMEL)
- During the removal installation procedures.

This collar is a solution to prevent spoiler droop. The anti-droop effect of the actuator makes a quick dispatch possible, if a spoiler actuator failure occurs.

The collar can be used in all the actuators independently of their positions.

The maintenance key tool used to change the mode of operation of the spoiler actuators is used for:

- Removal installations
- Special test.

In the maintenance position, the tool will prevent the spoiler panel closure because of its vertical position. This tool can be used on all spoiler actuators (servo-control and EBHA).

The maintenance mode depressurizes the actuator, so before each removal installation it is important to set the spoiler actuator to the maintenance mode.



SERVOCONTROL BEFORE COLLAR INSTALLATION

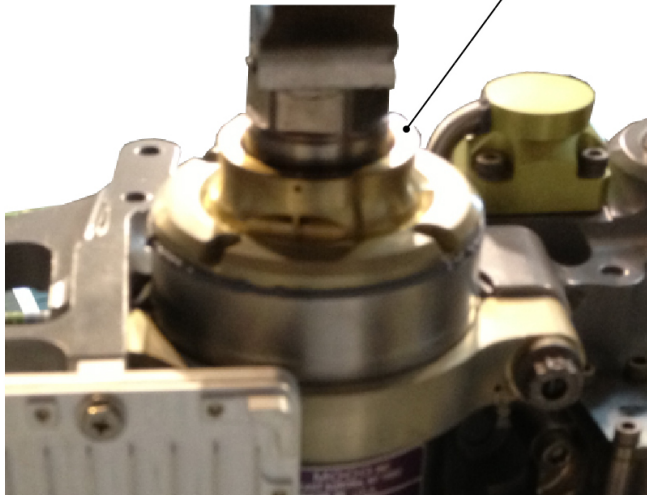

SERVOCONTROL SHOWN, SAME FOR EBHA

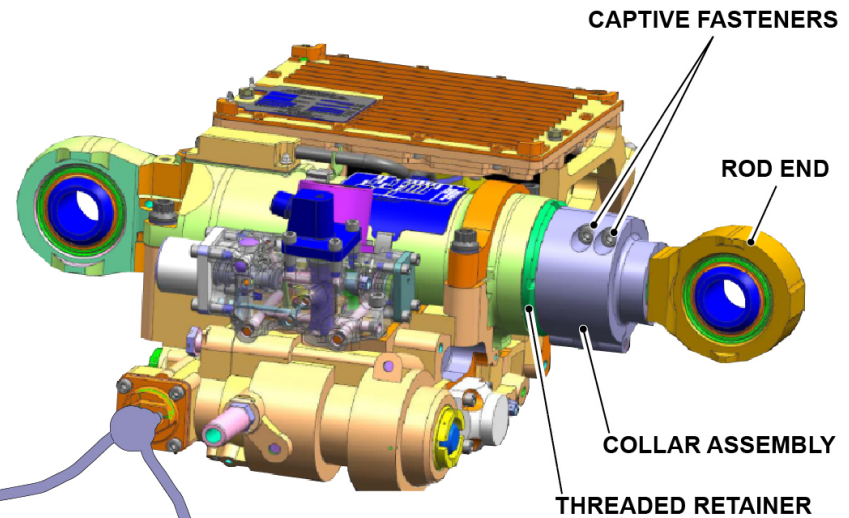

OPERATION MODE

MAINTENANCE MODE

EBHA: Electrical Backup Hydraulic Actuator

SPOILER: SPECIAL TOOLS

V1813401 - V01T0M0 - VM27MIFCSMA3001

---

**PRIMARY FLIGHT CONTROL SYSTEM (PFCS) MAINTENANCE (2/3)****Trimmable Horizontal Stabilizer Actuator: Electrical Motor  
Safety Tip**

When they operate the Trimmable Horizontal Stabilizer (THS) actuator, the electrical motors receive very high voltage power. The joule effect can generate heat.

Follow special safety rules when you work on the THS actuator.

The same electrical current is routed through the Electric Motor Control Unit (EMCU).

The safety precautions for the EMCUs and the electrical motors of the THS actuator are:

- Caution: HIGH VOLTAGE
- Caution: HOT SURFACE.

The same safety related warning/caution is applicable on the Electro-Hydrostatic Actuators (EHAs) and EBHAs because of the high voltage.

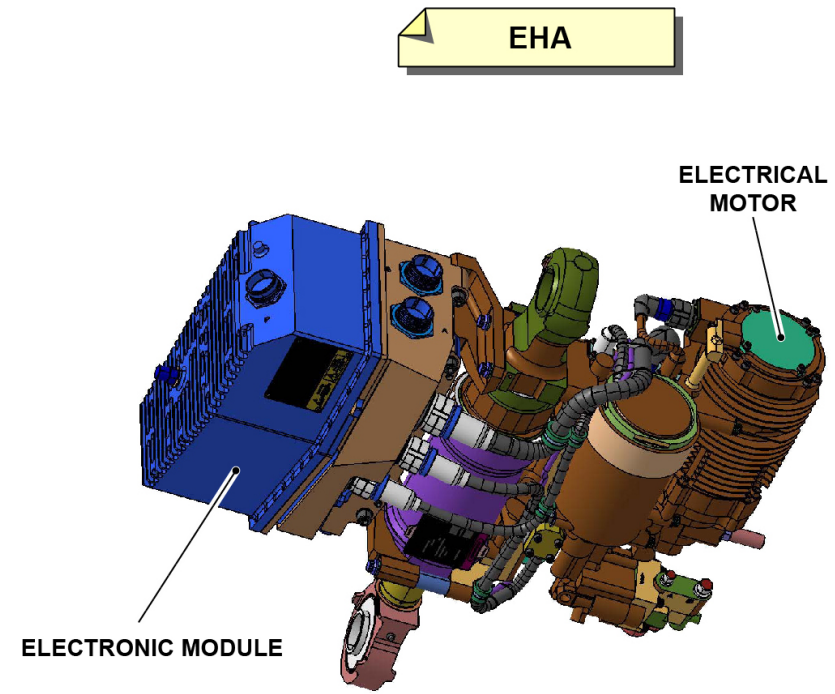
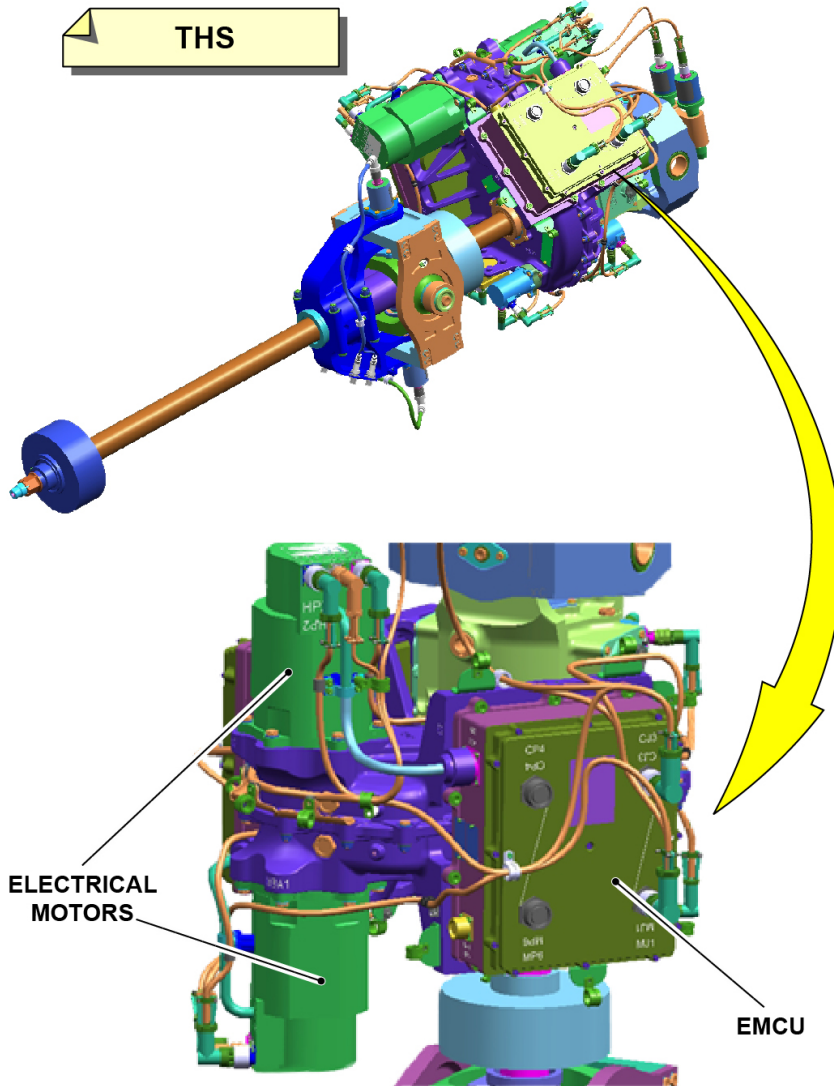

EHA: Electro-Hydrostatic Actuator  
 EMCU: Electric Motor Control Unit  
 THS: Trimmable Horizontal Stabilizer

TRIMMABLE HORIZONTAL STABILIZER ACTUATOR: ELECTRICAL MOTOR SAFETY TIP

V1813401 - V01T0M0 - VM27MIFCSMA3001

---

**PRIMARY FLIGHT CONTROL SYSTEM (PFCS) MAINTENANCE (2/3)****Actuator Safety Tips**

If you disconnect the hydraulic lines from the actuators, make sure that the applicable hydraulic system and the system reservoir are depressurized.

To avoid human factor issues, depressurize both systems and both reservoirs (Green and Yellow) before a hydraulic pipe removal from the actuators.

When you did this, depressurize the related actuator as follows:

- On the spoilers actuators (servo-control actuators and EBHAs), move the maintenance key to the maintenance mode position with the maintenance key tool.
- On the ailerons, elevators, rudder actuators (servo-control actuators and EHAs), press and hold the depress release valve until the accumulator pressure indicator shows the empty position.

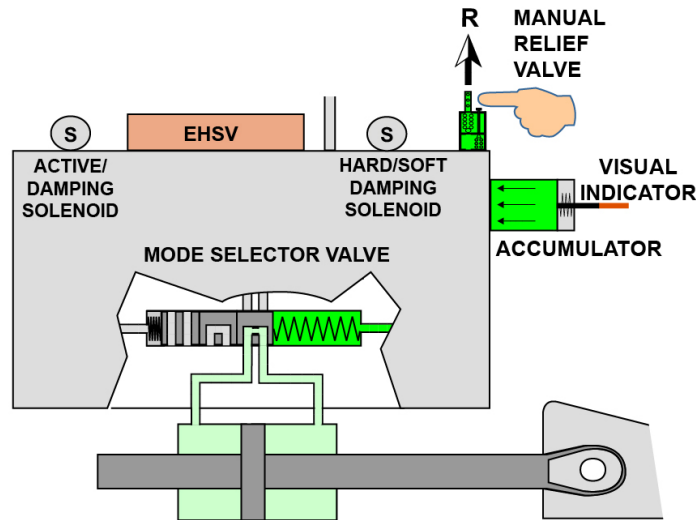

DIFFERENT RELATIVE POSITION COMPLIANT WITH THE TYPE OF SERVOCONTROL

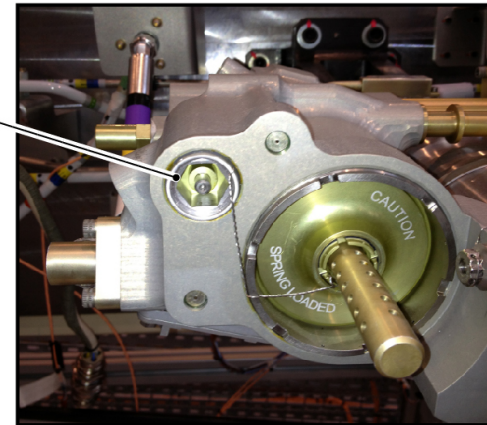

ACCUMULATOR DISCHARGE VALVE

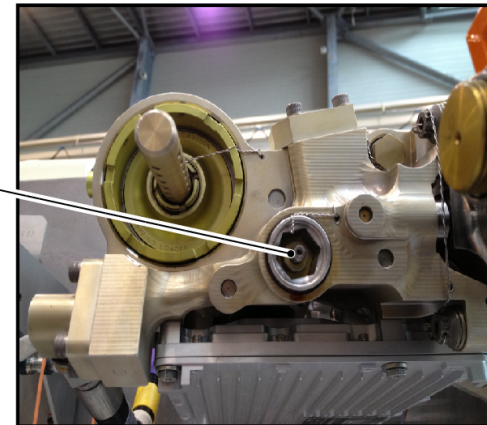
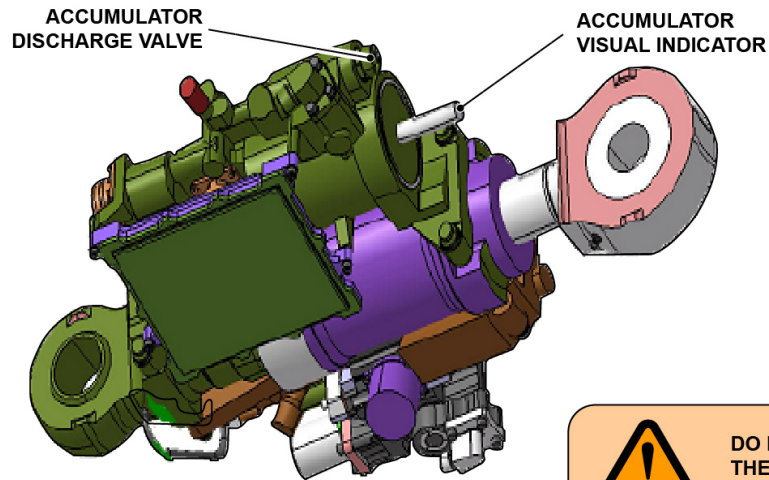

ACCUMULATOR DISCHARGE VALVE

EHSV: Electro Hydraulic Servo Valve

**CAUTION**

DO NOT TRY TO OPEN THE ACCUMULATOR RETAINING NUT. A SPRING LOADED DEVICE CAN CAUSE INJURY TO THE PERSONNEL OR DAMAGE TO THE EQUIPMENT.

ACTUATOR SAFETY TIPS

V1813401 - V01T0M0 - VM27MIFCSMA3001

---

**PRIMARY FLIGHT CONTROL SYSTEM (PFCS) MAINTENANCE (2/3)****Actuator Rigging: OMS procedure**

OMS menu pages are used to rig the actuators. The menu looks like this.

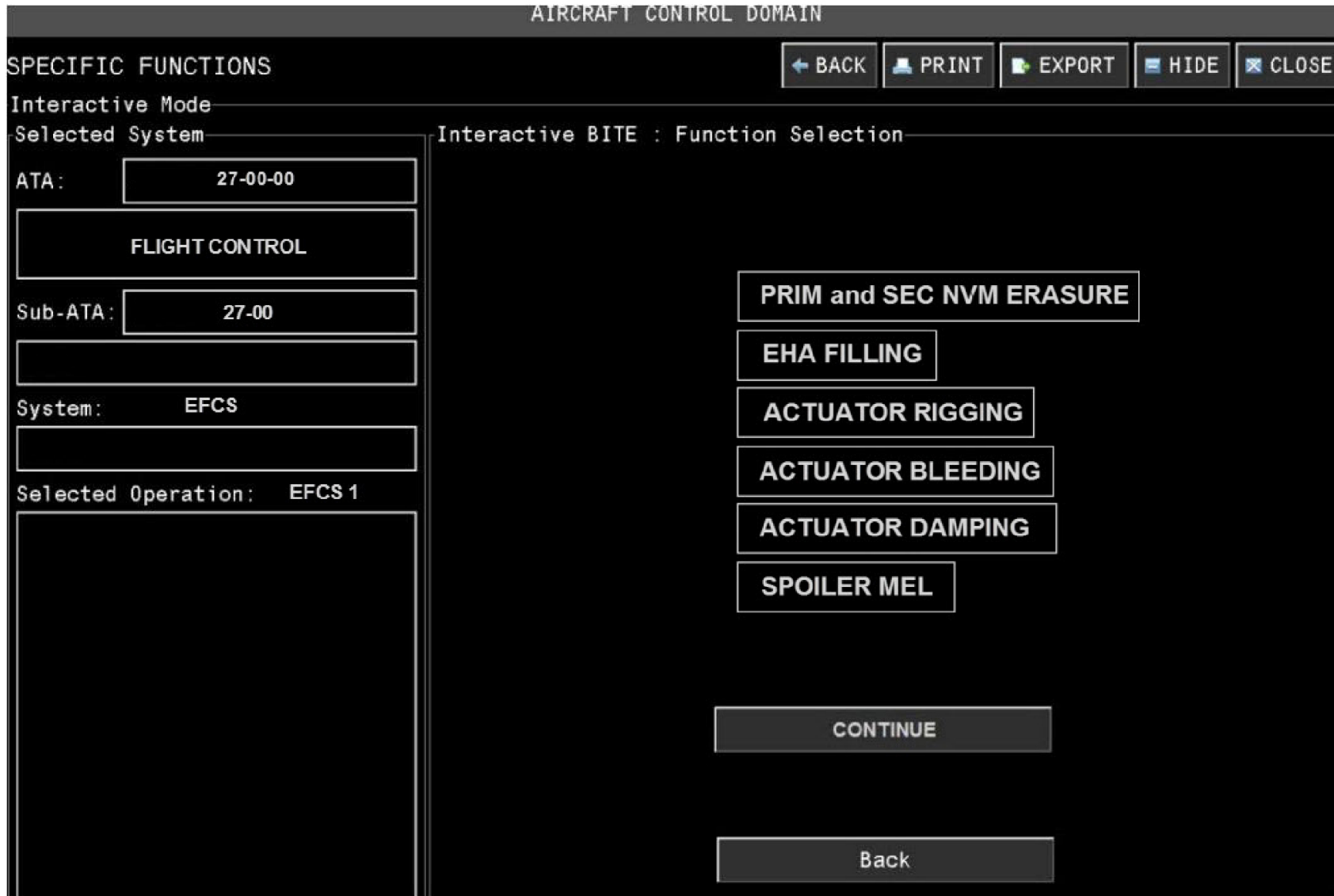

ACTUATOR RIGGING: OMS PROCEDURE

V1813401 - V01T0M0 - VM27MIFCSMA3001



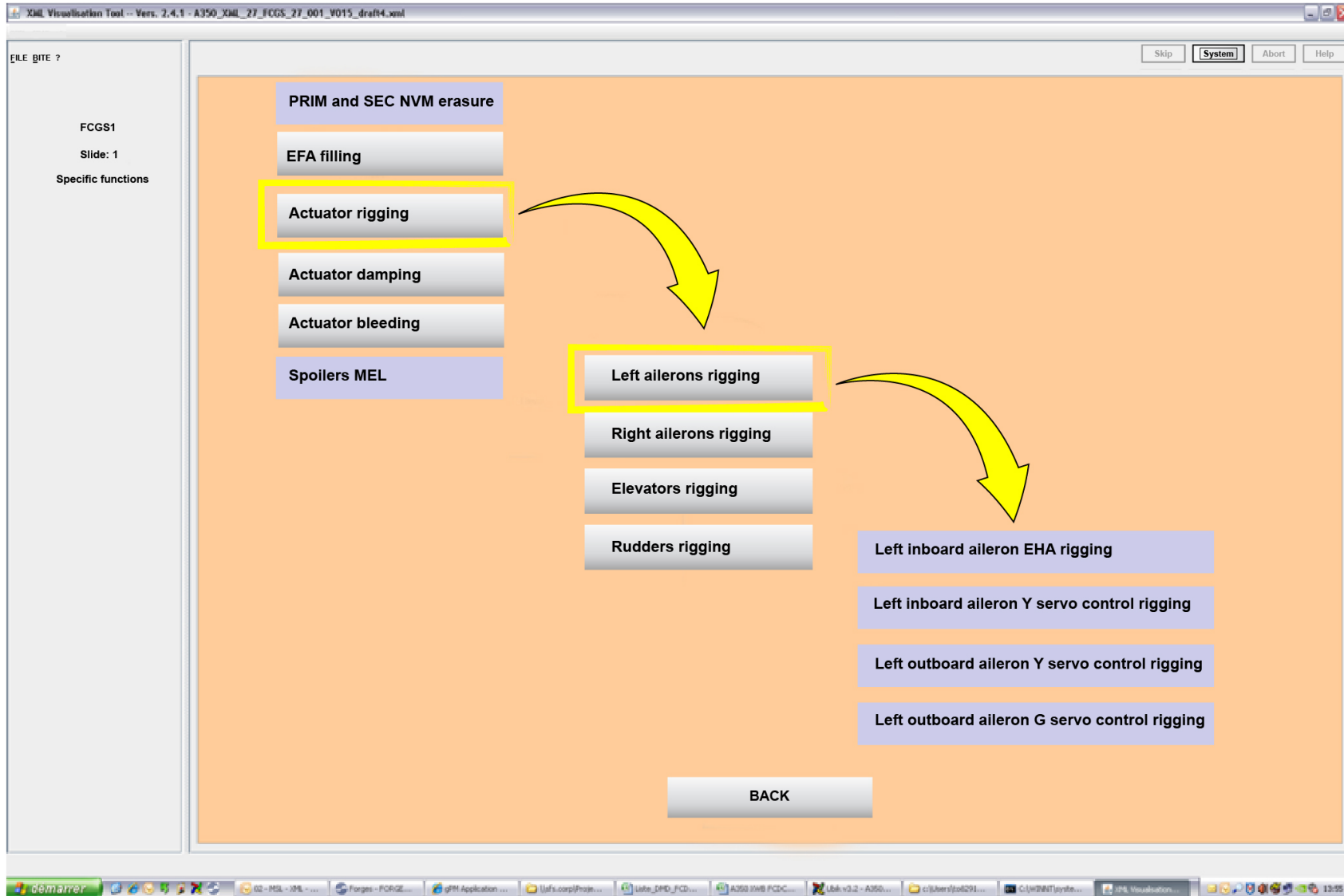

ACTUATOR RIGGING: OMS PROCEDURE

V1813401 - V01T0M0 - VM27MIFCSMA3001



This Page Intentionally Left Blank

## HIGH LIFT SYSTEM (HLS) CONTROL INPUTS DESCRIPTION (3)

### Control Inputs/Interfaces

#### Slat/flap control lever

The slat/flap control-lever assembly is a LRU.

The flight crew manually selects the slat/flap configuration for take-off, approach and landing flight phases through the FLAPS lever.

The control lever assembly has:

- A control lever and its mechanism.
- Two Command Sensor Units (CSUs).

The control lever assembly includes five gated positions (0, 1, 2, 3, FULL). The flap lever mechanism includes the knob, the trigger mechanism and the lever arm that the flight crew operates for the control inputs. To move the lever, the operator must lift the trigger to disengage the detent mechanism used to lock the lever in its selected position. Two baulks (at positions 1 and 3) prevent the full range operation of the lever in a single movement.

When lifted up and moved, the pilot operates the lever. The two CSUs change the lever movements into electrical sensor signals. The CSU1 is connected to the slat Flap Control Computer (SFCC) 1 and the CSU2 is connected to the SFCC2.

#### Slat/flap control computers

Two SFCCs (ACTIVE/ACTIVE concept) control and monitor the high lift system. Each SFCC includes two channels:

- One slat channel.
- One flap channel.

The two SFCCs are interchangeable.

The SFCCs are used for the control, monitoring and electronic maintenance of the high lift system. To do these tasks, the SFCCs receive different inputs. The SFCCs also give some necessary outputs to control the high lift system to some A/C systems.

#### Slat/flap reset switches

Reset Switches are available for the recovery of the SFCCs. There is one reset switch for each SFCC channel. The two pairs of reset switches are located on the overhead panel:

- The SLATS1 and FLAPS1 switches, located on the overhead Integrated Control Panel (ICP) CAPT RESET panel, reset the slat and flap channels of the SFCC1.
- The SLATS2 and FLAPS2 switches, located on the overhead ICP F/O RESET panel, reset the slat and flap channels of the SFCC2.

#### Interfaces

Interface with the Air Data and Inertial Reference System (ADIRS):

- There is a two-way communication with the ADIRS via the AFDX and ARINC429.
- The SFCCs transmit data to establish control law switching in the ADIRS.
- SFCCs receive air data from the ADIRUs to calculate automatic high lift functions.

Interface with the Primary Flight Control System (PFCS):

- The SFCCs send the slat, flap and lever positions to the PFCS for the Adaptive Droop Hinge Function (ADHF) through the AFDX network.
- The SFCCs also receive command orders from the PFCS to move the flaps in variable camber configuration during cruise.
- The one way ARINC429 communication is used as a back-up to transmit the flap position to the PFCS.
- In cruise, the SFCCs receive small flap extension or retraction commands orders from the PFCS for the A/C performance optimization.

Interface with the LGERS:

- The one-way AFDX communication from the LGERS transmits the ground/ flight status (weight on wheels) to the SFCCs to compute internal functions.

Interface with the Propulsion Control System (PCS):

- The SFCCs send the slat and lever positions to the PCS for the engine cowls opening inhibition if the slats are extended.
- The PCS is also used to inhibit the slat extension if the engine cowls are open.

Interface with the Hydraulic (HYD) system:

- There is a one-way communication between the high lift system and the HYD system.
- The Hydraulic Monitoring Control Application (HMCA) transmits data to the high lift system through the AFDX network. They give the pressure status of the yellow and green HYD system to the SFCCs. This information is used for a specific inhibition of the slat/flap system.

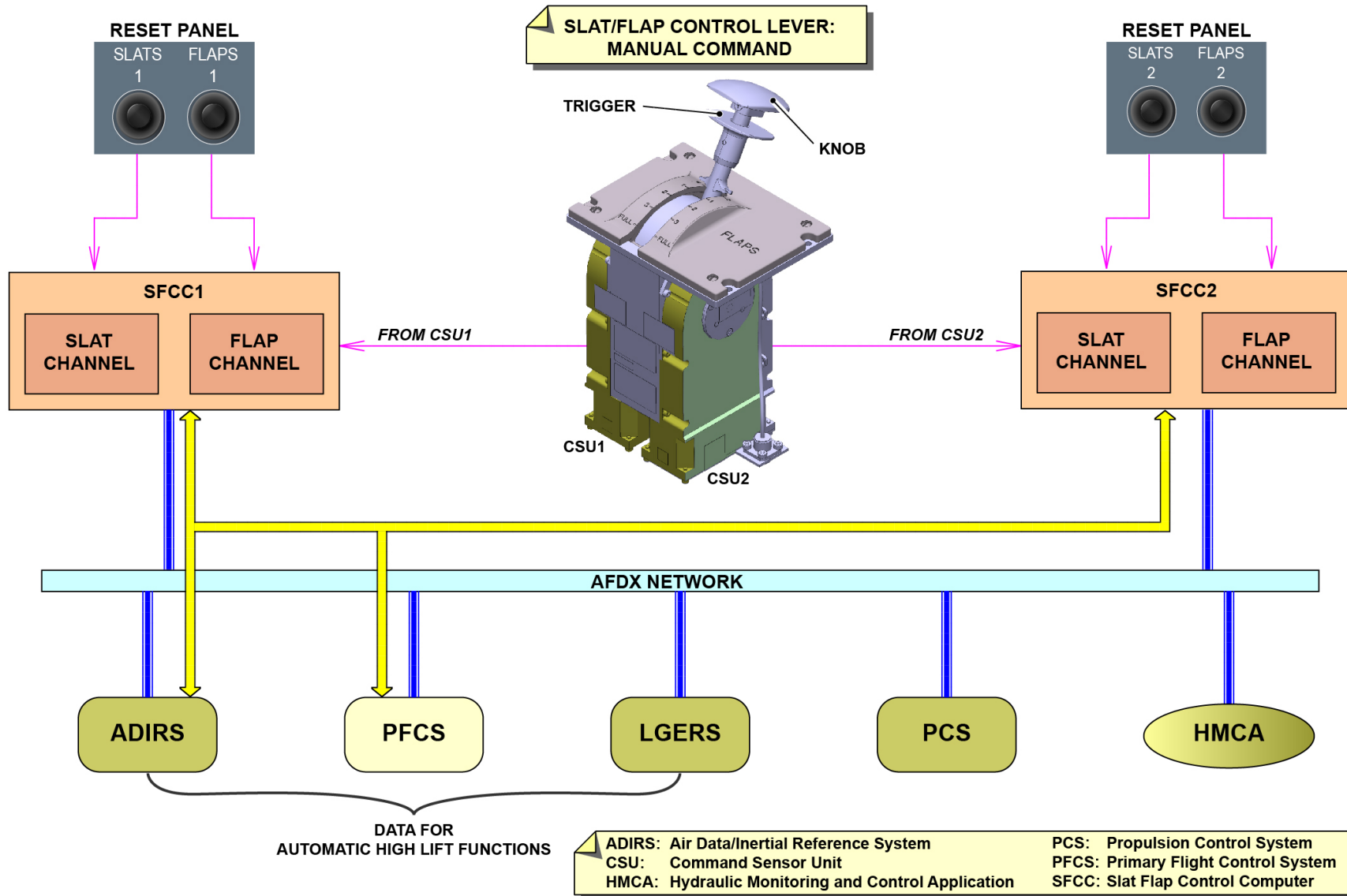

CONTROL INPUTS/INTERFACES - SLAT/FLAP CONTROL LEVER ... INTERFACES

V1813401 - V01T0M0 - VM27D8SFCTL3001

This Page Intentionally Left Blank

## SLAT AND DROOP NOSE DESCRIPTION (3)

### Computation Group

#### Slat system description

The slat actuation and transmission system includes:

- A slat/flap control lever
- The slat channel of the Slat Flap Control Computers (SFCCs)
- The slat Power Control Unit (PCU)
- Transmission components (e.g. gearboxes, transmission shafts)
- The slat geared rotary-actuators and the slat surface kinematics
- Feedback Position Pick-off Units (FPPUs)
- Torque Sensor Units (TSUs)
- Wing Tip Brakes (WTBs)
- Asymmetry Position Pick Off Units (APPUs).

The design of the SFCCs makes cross-talking possible. It is used to compare computation results, monitoring functions, failure detection and validation.

The system drive command comes from the slat/flap lever input (manual command) and is sent to the SFCCs.

The automatic drive commands are also started under special conditions (e.g. protection laws).

The slat PCU is a hybrid design type and is composed of an electric motor and a hydraulic motor.

The slat PCU motors drive the transmission in accordance with signals transmitted by the slat channels of the SFCCs.

The two motors are active during normal slat operation (active/active concept = speed summing). The slat PCU operates transmission components through a differential gearbox. The Power-Off Brake and Pressure-Off Brake (POB) are installed on the PCU. They hold the motors in position during normal operation or in case of specific failures.

The slat PCU operates the slat transmission with:

- Transmission torque shafts, which are used to transmit the PCU torque to the drive stations, and also to compensate the wing flexion.

- Bevel gearboxes, which are used to adapt the slat transmission path to the wing shape.

- Geared rotary actuators, which are installed in each drive station (2 per surface) and used to change the transmission rotation into the droop nose deflection and the slat surface translation.

Sensors are used by the SFCCs to monitor the system.

Electronic TSUs are used to monitor the torque applied to the LH and RH transmissions (overload /jamming detection).

The FPPU is used to monitor the slat system position.

The APPUs are used to detect some specific failures.

The basic function of the slat WTBs is to lock and to hold the system, in case of a specific failure:

- Mechanical failure or rupture
- Total electrical power loss or shutdown.

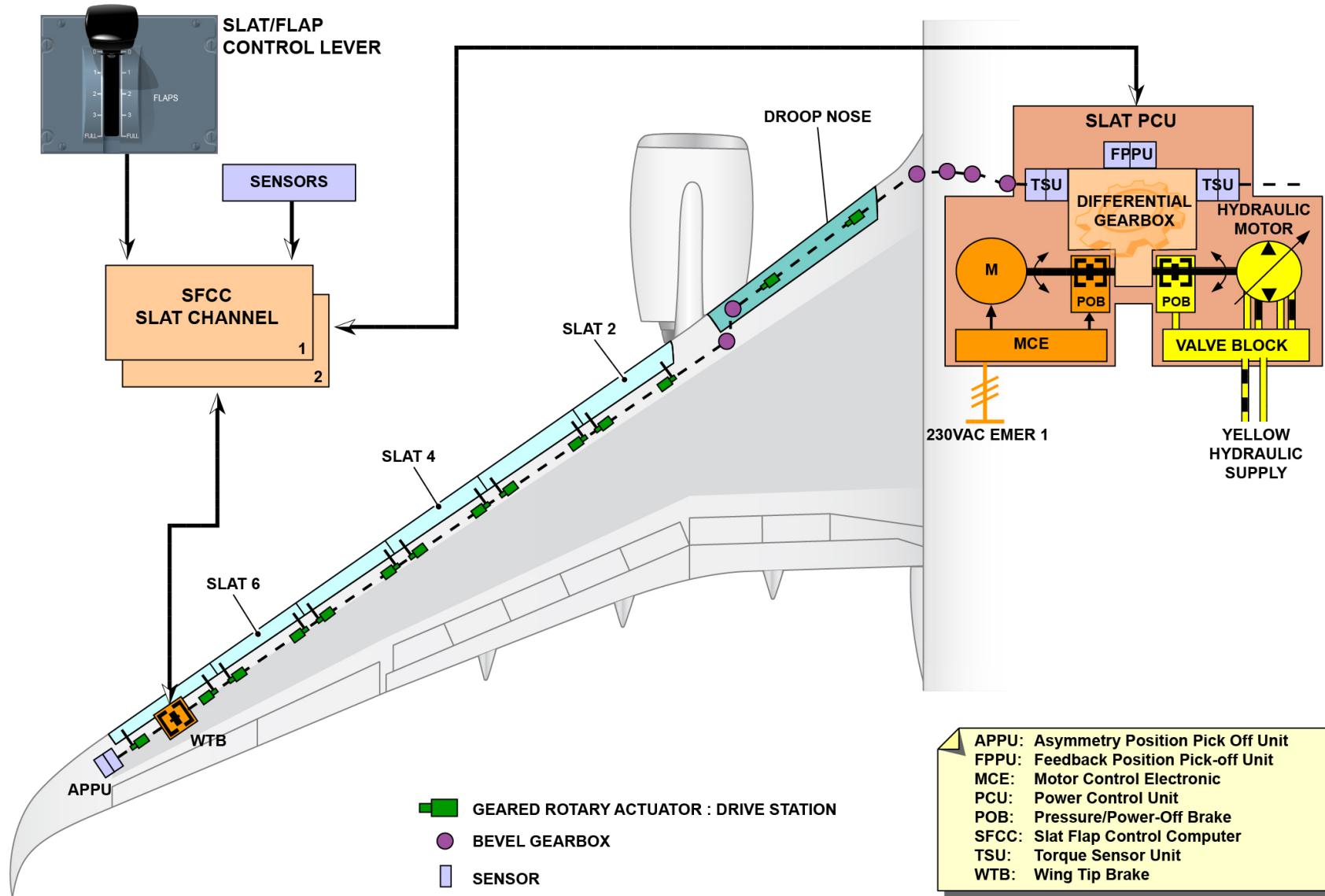

COMPUTATION GROUP - SLAT SYSTEM DESCRIPTION

V1813401 - V01T0M0 - VM27D9SLATS3001

## SLAT AND DROOP NOSE DESCRIPTION (3)

### Computation Group (continued)

#### Slat system control

##### Slat PCU control

When the SFCCs slat channels are energized and when no failure is detected, the WTB solenoids are energized (brakes released). If energized, only one of the two solenoids is sufficient to release the WTB.

WTB solenoids will be de-energized (brakes applied) only in case of critical failure.

The SFCCs slat channels compute the slat-system driving-sequence based on:

- The control lever inputs (manual control function) from the Command Sensor Units (CSUs)
- The ADIRS (Air Data/Inertial Reference System) (calibrated air speed, altitude and angle of attack) and the LGERS (A/C on ground or in-flight) for some automatic functions.

If a selection is made, each slat channel controls its own PCU motor, pressure or power-off brake independently from the other to get the new computed target position. The slat channel of SFCC 1 controls and monitors the electrical motor. The slat channel of SFCC 2 controls and monitors the hydraulic motor.

A cross-talk allows transfer of data between the SFCCs. It is used to compare computation results, monitoring functions, failure detection. The PCU electrical part is controlled by the slat channel of SFCC 1 as follow:

- (1) The 230VAC Emergency 1 (EMER 1) supplies the Motor Control Electronic (MCE) with electrical power through the Remote Control Circuit Breaker (RCCB).
- (2) The SFCC 1 sends an enable signal to the MCE for activation.
- (3) Before the motor starts, the power-off brake must be released. The SFCC 1 sends a release signal to the MCE, which supplies the power-off brake.

- (4) When the output shaft can freely rotate, SFCC 1 sends a speed command signal to the MCE. The MCE supplies DC electrical power to the electrical motor to drive the transmission.

The PCU hydraulic part is controlled by the slat channel of SFCC 2:

- (1) SFCC 2 sends a PCU enable signal to the enable solenoid valve to pressurize the hydraulic valve block.
- (2) SFCC 2 sends a POB release signal to the brake solenoid valve.
- (3) SFCC 2 sends a speed command signal to the Electro-Hydraulic Servo Valve (EHSV) to control the speed and direction of the rotation with the hydraulic motor to drive the transmission.

The design and power supplies of the SFCCs, slat PCU and WTBs let the slat system operate without hydraulic pressure, with the PCU electrical part supplied by 230VAC EMER 1.



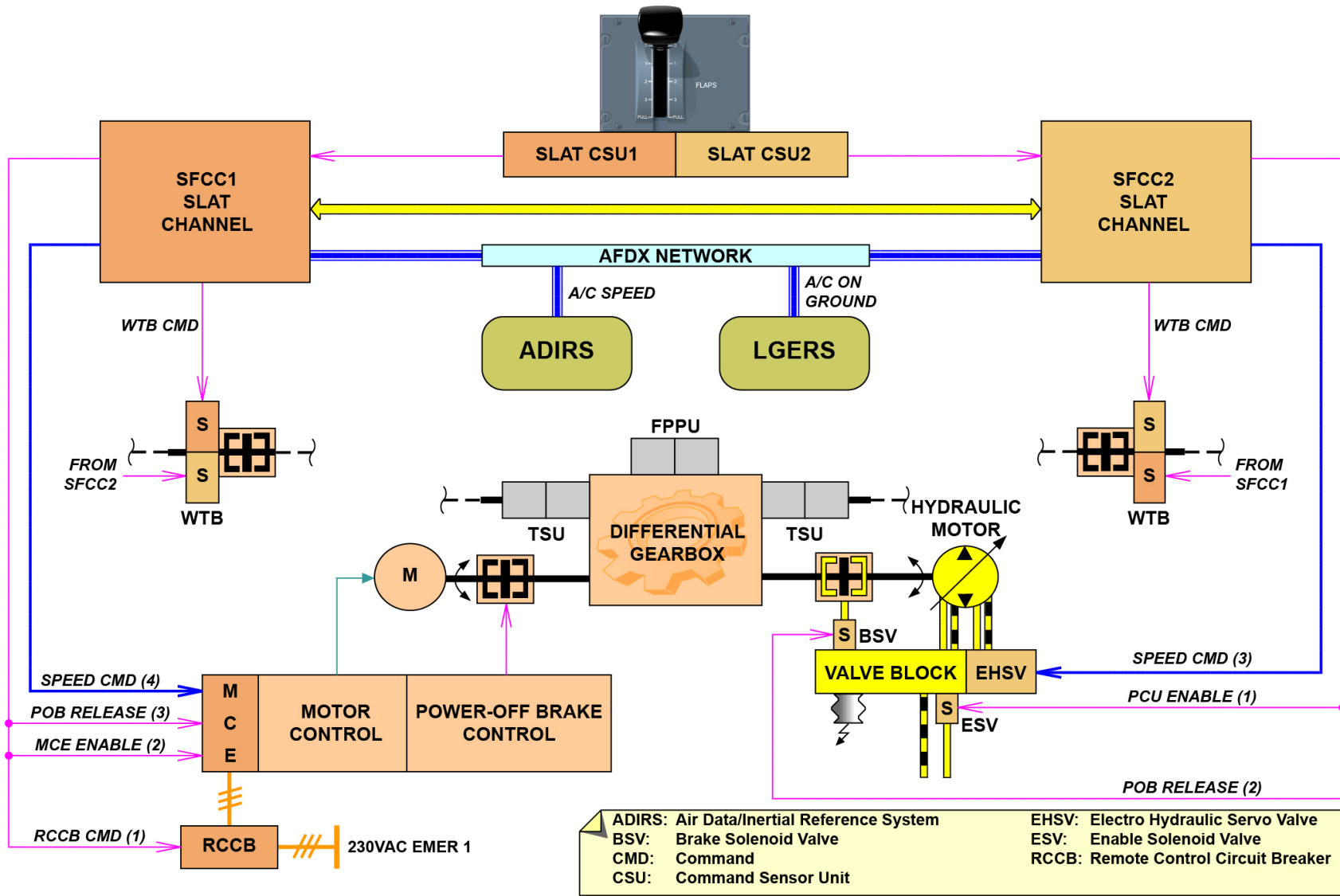

COMPUTATION GROUP - SLAT SYSTEM CONTROL

V1813401 - V01T0M0 - VM27D9SLATS3001

---

## SLAT AND DROOP NOSE DESCRIPTION (3)

### Computation Group (continued)

#### Slat system monitoring

The start-up sequence must make sure that the hydraulic PCU POB will be released only at sufficient pressure levels to fully release the brake. This is monitored by a pressure transducer on the valve block. Data is sent to the SFCC 2.

The MCE monitors the electric motor and the electrical POB. It also performs an internal monitoring. All the data are sent to the SFCC 1. The function of the TSU is the transmission shaft over-torque monitoring (in case of transmission jamming).

The slat channels of the SFCCs use feedback signals which are proportional to the torque of the related PCU output shaft.

A PCU shut-down is commanded in case of over-torque.

The slat system is monitored with the sensors that follow:

- The FPPU

The FPPU gives information about slat actual position to the SFCCs that use this data for system monitoring (ie: uncommanded movement and transmission jamming).

- The APPUs

The APPUs are used to monitor asymmetry, runaway or overspeed conditions.

The Position Pickoff Units (PPUs) are connected to SFCC 1 and SFCC 2.

A proximity sensor in each WTB gives a released or applied status to the SFCC 1 only.

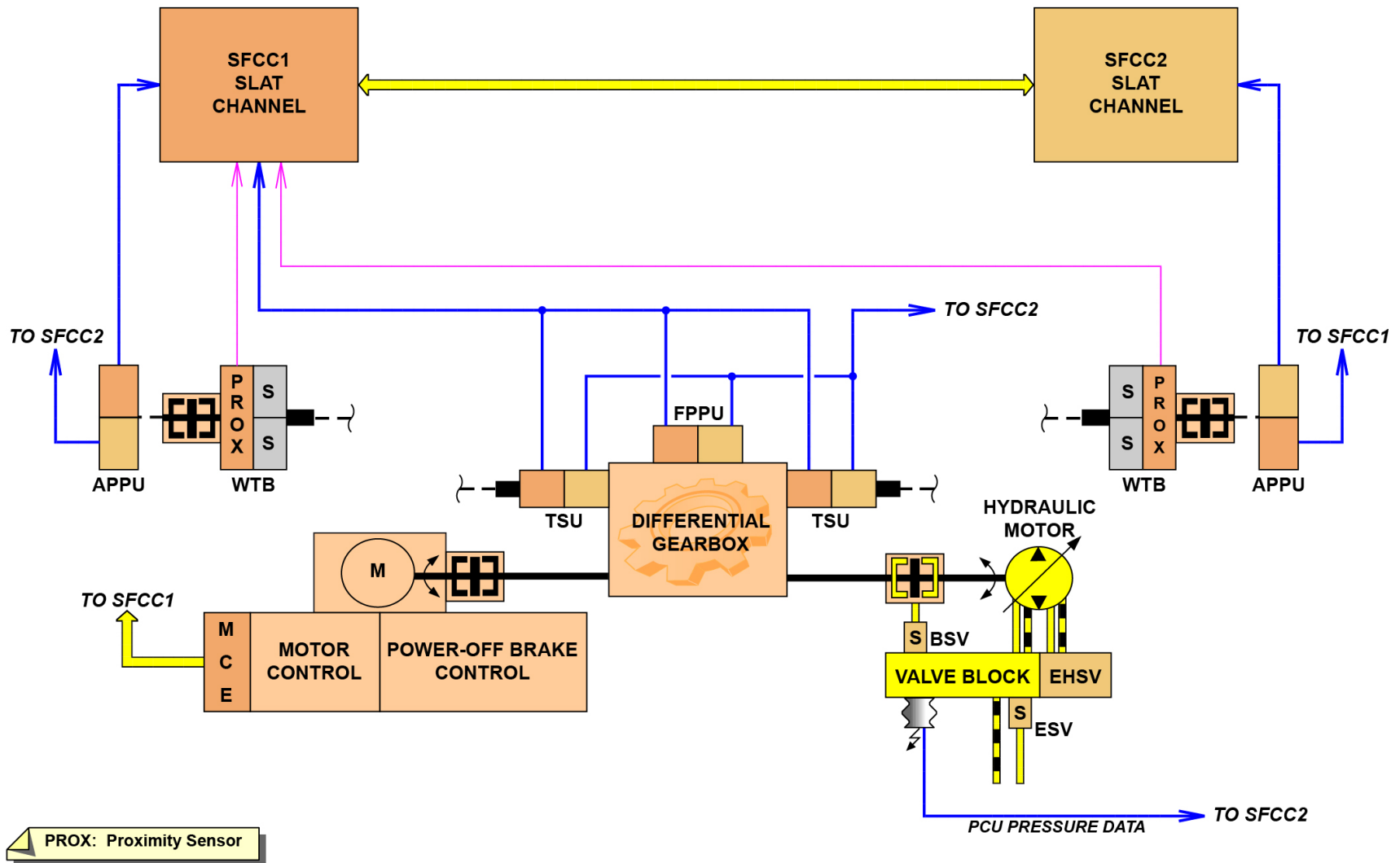

COMPUTATION GROUP - SLAT SYSTEM MONITORING

V1813401 - V01T0M0 - VM27D9SLATS3001

## SLAT AND DROOP NOSE DESCRIPTION (3)

### **Slat PCU: Actuation Group**

The electrical part of the slat PCU includes:

- A MCE
- An electrical motor (e-motor)
- A power-off brake.

The FPPU continuously monitors the positions of the slat drive system to give a smooth and accurate surface deployment.

At each output of the PCU, a TSU sends electrical signals to the SFCCs to compute and monitor the transmission torque of each wing.

The primary components of the hydraulic part of the slat PCU are:

- A hydraulic manifold with an enable solenoid valve, a brake solenoid valve and a pressure transducer
- A POB
- A hydraulic motor with its electro-hydraulic servo valve.

A differential gearbox transmits the movement from the electrical and hydraulic motors to the flap transmission.

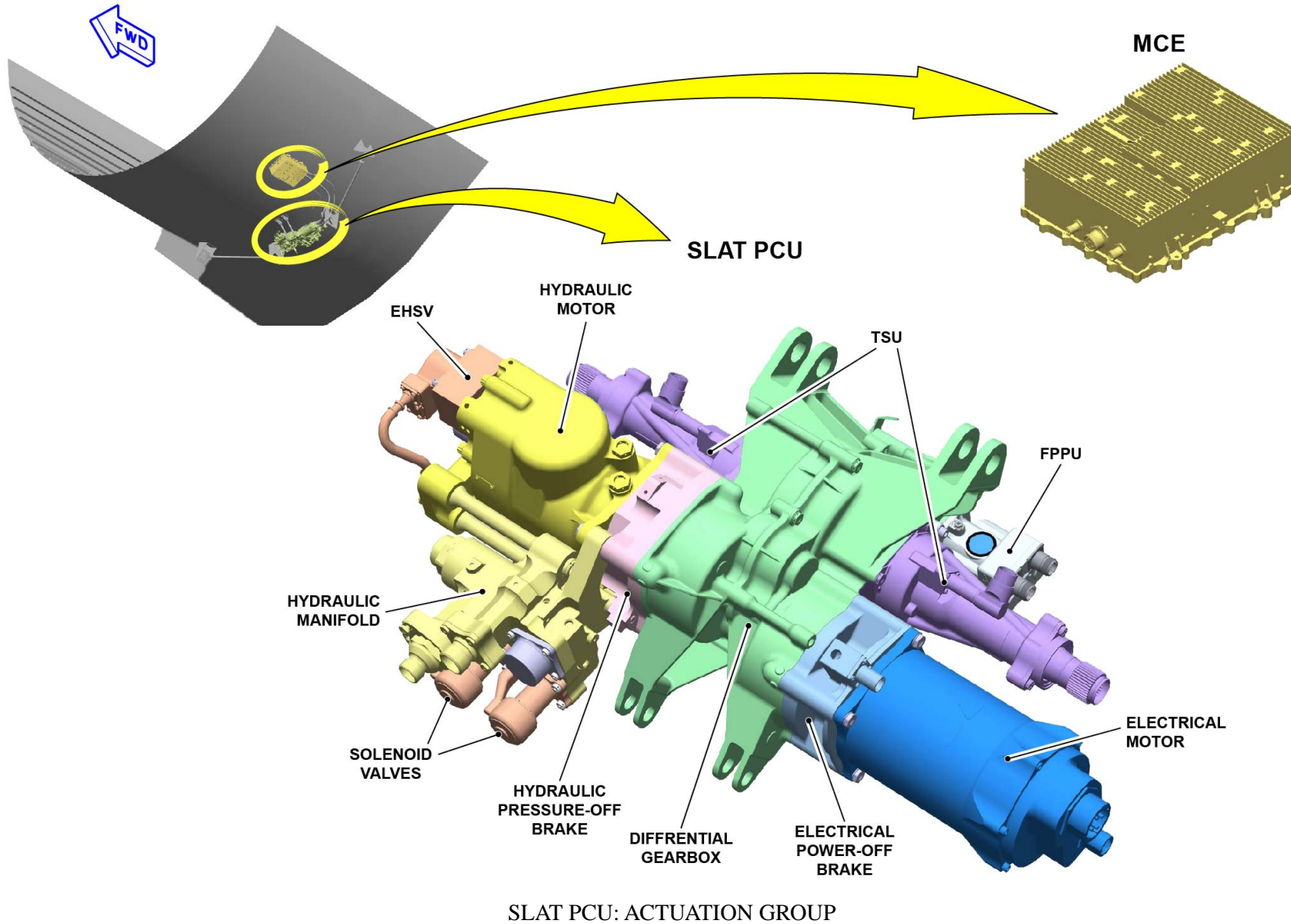

V1813401 - V01T0M0 - VM27D9SLATS3001

## SLAT AND DROOP NOSE DESCRIPTION (3)

### **Droop Nose Actuators and Surface Kinematics: Transmission Group**

The slat PCU sends the torque to the actuators through the transmission shafts and the bevel gearboxes.

The function of the geared rotary actuators and the surface kinematics is to change the rotation into deflection movements.

To do this, there are two droop-nose geared rotary-actuators installed for each droop nose surface. Each droop nose has five tracks (two of them are driven and three of them are non-driven).

#### **Droop nose actuators**

The droop-nose geared rotary-actuators have an input shaft in one side of the geared actuator and an output shaft in the other side.

Between the input shaft and the output shaft, the geared rotary actuator has a torque limiter that protects the structure against an overtorque at a set value generated during a system locking or jamming. A visual indicator shows the activation of the torque limiter (useful for troubleshooting purposes).

In case of locking or jamming, the over-torque is transmitted to the actuator housing and from there to the wing structure, if that happens, a recycle operation is needed.

During reverse operation (recycle) if the torque level decreased below the setting value, the torque limiter unlocks automatically and the system is operative. The torque limiter visual indicator stays out. The visual indicator must be manually reset on the ground and it is used to identify the source/location of the problem.

The actuator is filled with an approved semi-fluid lubricant.

#### **Surface kinematics**

The two gear rotary actuators move each droop nose (hinge arm 2 and hinge arm 4) through actuator levers and drive links connected to the

hinge arms. The surface kinematics components connect and transmit the actuators movement to the droop nose surface.

The gear rotary actuator is connected to the actuator lever. The actuator lever is connected to the drive link, which moves the hinge arm. The hinge arm is connected to the rib at one side and to the droop nose surface at the other side.

### DROOP NOSE KINEMATICS

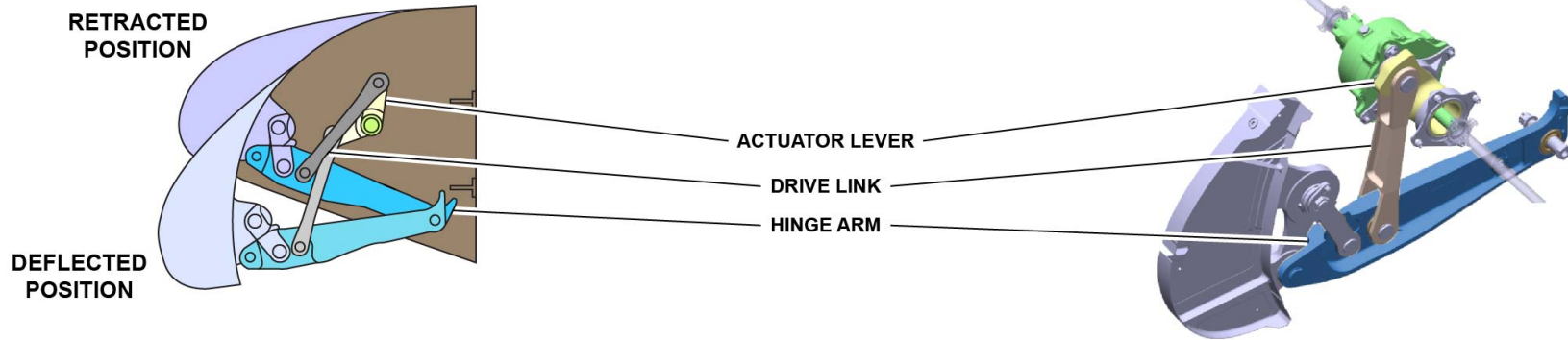

### DROOP NOSE TRANSMISSION

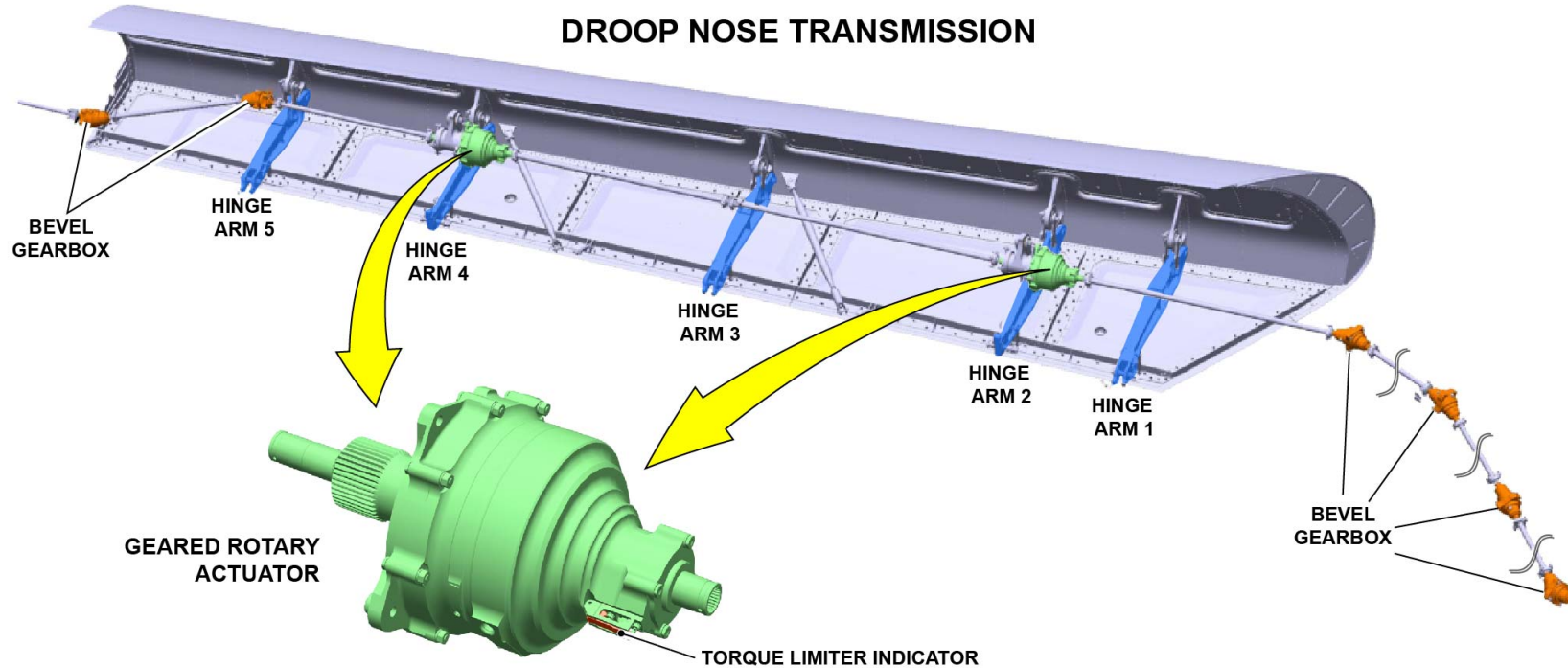

### DROOP NOSE ACTUATORS AND SURFACE KINEMATICS: TRANSMISSION GROUP - DROOP NOSE ACTUATORS & SURFACE KINEMATICS

V1813401 - V01T0M0 - VM27D9SLATS3001

## SLAT AND DROOP NOSE DESCRIPTION (3)

### **Slat 2 to 7 Actuators and Surface Kinematics Wing Tip Brake: Transmission Group**

The function of the gear rotary actuators and the surface kinematics is to change a torque shaft rotation into extension or retraction movements. The slat actuation system contains twelve gear rotary actuators per wing, two per surface.

#### **Geared rotary actuators**

Each gear rotary actuator has an input shaft and an output shaft. The gear rotary actuator has a torque limiter that locks the transmission if the torque is more than a maximum value, and transmits it to the actuator housing. The torque limiter shows the torque-limiter indicator pop out.

After the system reverse operation (recycle operation), if the output torque level is less than a set value, the system torque limiter unlocks the transmission automatically, but the torque limiter indicator stays out. The mechanical indicator can be manually reset on the ground and it is used to locate/identify the source of the problem.

The actuator is filled with an approved semi-fluid lubricant.

#### **Surface kinematics**

The surface kinematics components connect and transmit the output shaft movements of the two gear rotary actuators to the slat surface through a rack-and-pinion mechanism.

#### **Wing tip brakes**

At each transmission system end, a power-off brake of the WTB type is installed to make sure that the system transmission is locked in its current position if there are critical failures (with WTB both solenoids de-energized).

Each WTB has a brake system mechanism with:

- A proximity sensor (brakes applied or released)

- A manual release device for maintenance purposes.

The WTB includes a manual release device that releases the brake during specific maintenance operation or rigging of the slat system on ground.



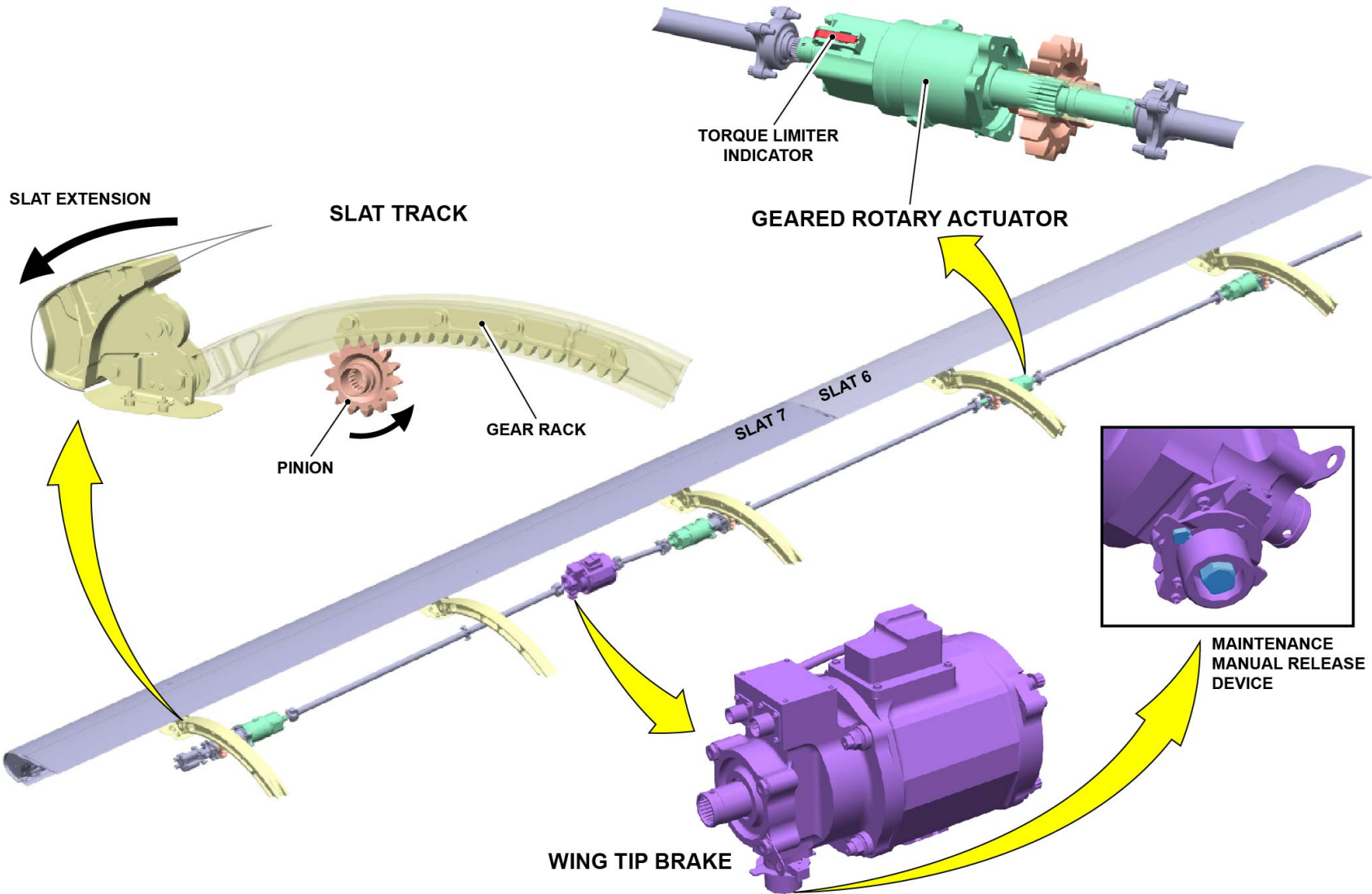

V1813401 - V01T0M0 - VM27D9SLATS3001

**SLAT 2 TO 7 ACTUATORS AND SURFACE KINEMATICS WING TIP BRAKE: TRANSMISSION GROUP - GEARED ROTARY ACTUATORS ... WING TIP BRAKES**

## SLAT AND DROOP NOSE DESCRIPTION (3)

### Slat System Sensors

The SFCCs continuously monitor the slat drive-system position with the following sensors:

- One FPPU mounted on the PCU
- Two APPUs, one at each outer end of the transmission
- Two TSUs mounted on the RH and LH output shafts of the PCU.

The APPUs and the FPPU are used to measure the position and speed of the slat system and the transmission system integrity. Each PPU is connected to SFCC 1 and SFCC 2. They supply the same information to the two system control channels. If one channel does not operate, the system will be then controlled and monitored by the remaining channel at half speed.

A zero indication window is installed on each APPU or FPPU to allow a zero position adjustment for rigging/installation purposes.

A locking plate is used to lock the shaft for removal/ installation purposes. The slat channel of each SFCC uses the TSU feedback signals which are proportional to the torque generated in the LH or RH PCU output shaft. If the torque in one of the output shaft gets a specified level (over-torque threshold), the SFCCs take authority over the PCU by commanding a PCU shutdown.

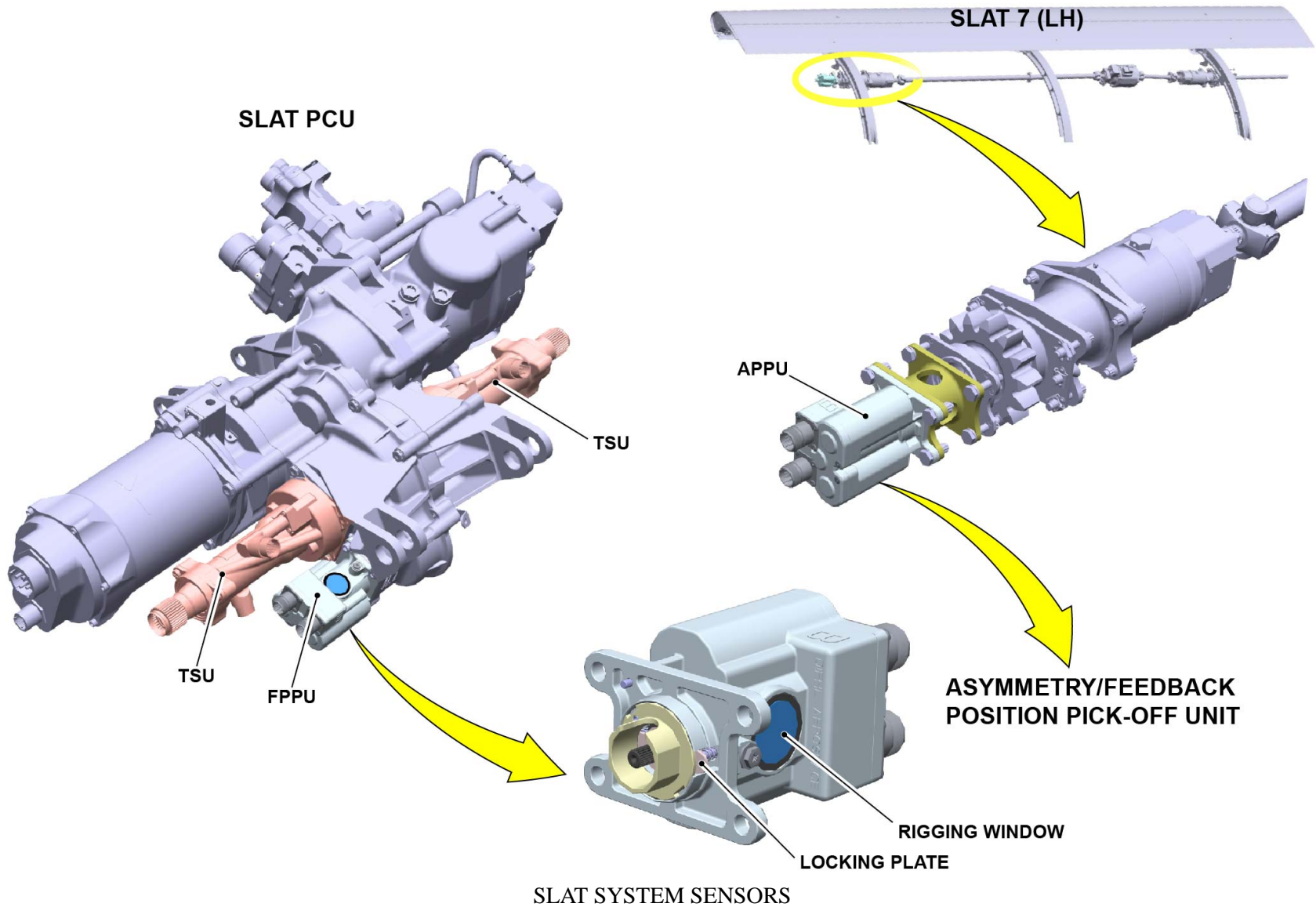

V1813401 - V01T0M0 - VM27D9SLATS3001

## SLAT AND DROOP NOSE DESCRIPTION (3)

### **Slat System Half-Speed Configuration**

A half speed configuration is engaged if there is:

- A loss of one SFCC slat channel
- A loss of the hydraulic power (or hydraulic power not available)
- A loss of electrical power supply, component, etc.

If one SFCC channel has a failure, its related PCU motor is stopped and its brake (power or pressure-off) is applied. The operation is possible only at half speed, using the other slat channel.

When the hydraulic supply is not available, the SFCC 2 slat channel stops its related PCU motor and its POB is applied. The operation is possible only at half speed with the electric motor using the SFCC 1 slat channel.

If the SFCC 1 slat channel detects an e-motor failure, this channel stops its related PCU e-motor and its power-off brake is applied. The operation is still possible only at half speed with the hydraulic motor using the SFCC 2 slat channel.

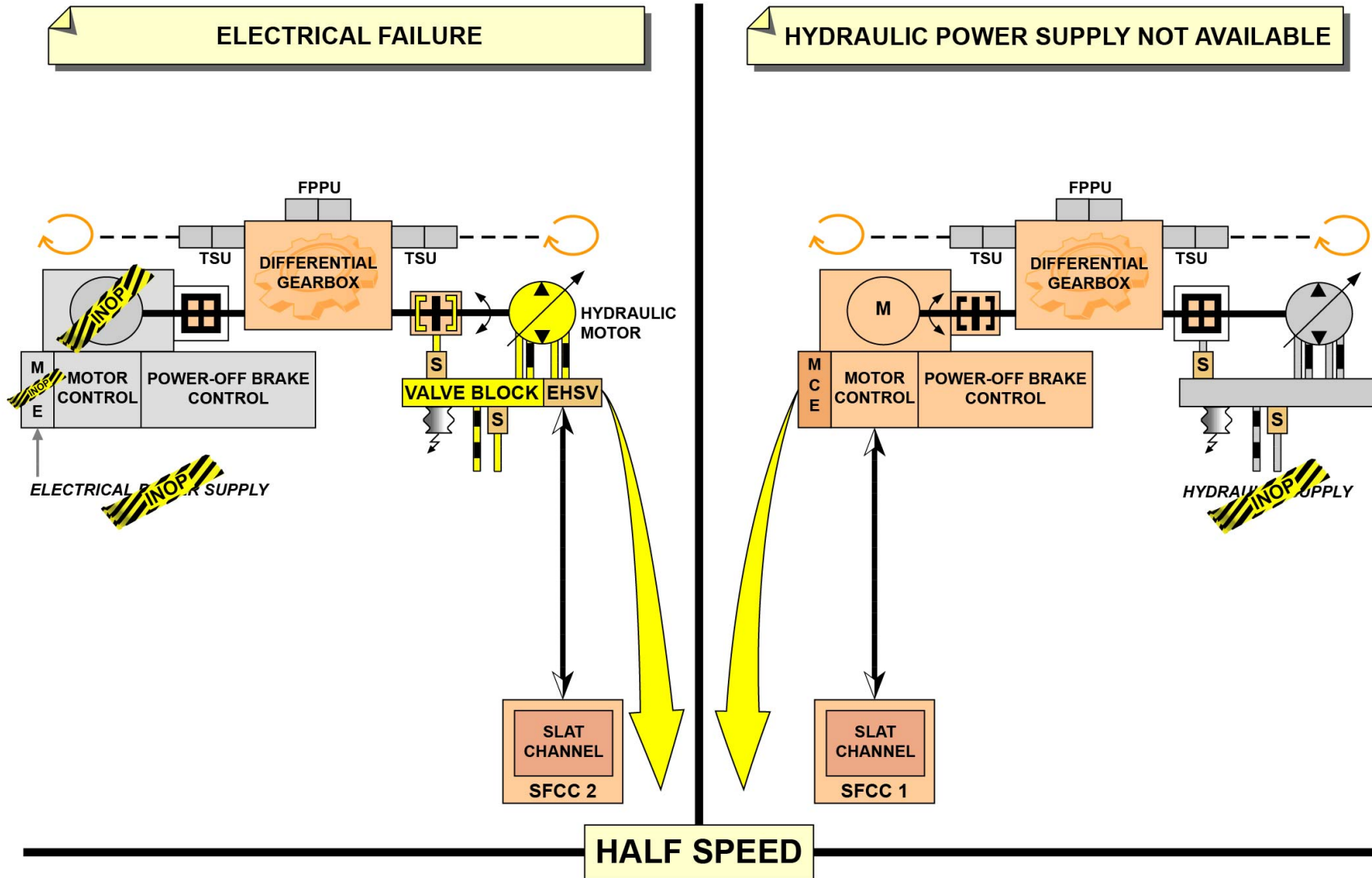

SLAT SYSTEM HALF-SPEED CONFIGURATION

V1813401 - V01T0M0 - VM27D9SLATS3001

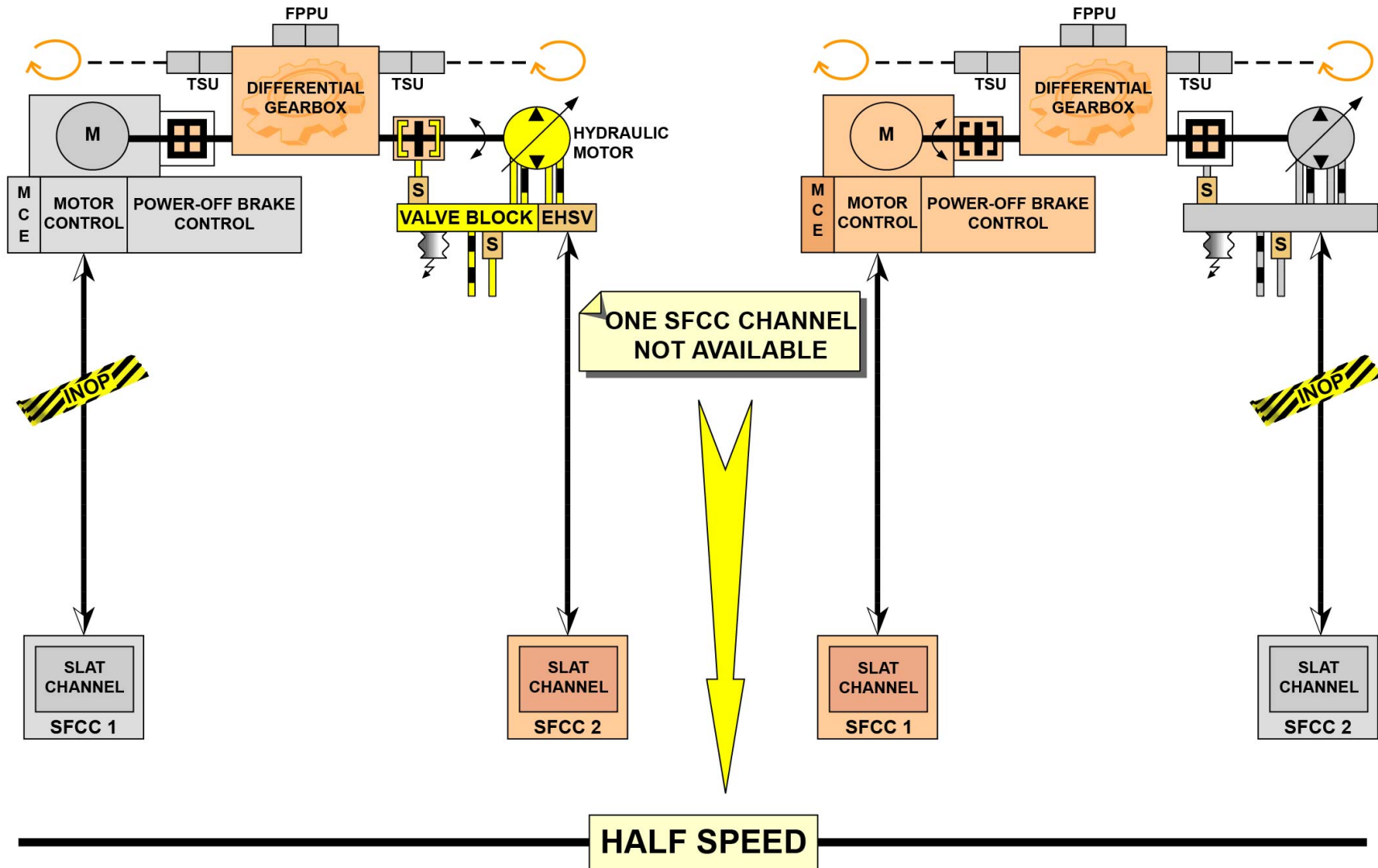

SLAT SYSTEM HALF-SPEED CONFIGURATION

V1813401 - V01T0M0 - VM27D9SLATS3001

This Page Intentionally Left Blank

## SLAT AND DROOP NOSE DESCRIPTION (3)

### Transmission Group Failures

A mechanical failure (transmission shaft or PCU mechanical part) can cause an asymmetry, overspeed or uncommanded movement.

Consequently, the SFCCs command a PCU shut-down and the POBs and WTBs are applied.

The SFCCs monitor the transmission, based on the APPUs, FPPU and TSUs feedback signals.

Slat asymmetry monitoring:

- An asymmetry is a position difference between the LH and RH APPUs. Asymmetry is usually due to a broken shaft between both APPUs. The detection is made through the LH and RH APPUs value comparison.

Slat overspeed monitoring:

- An overspeed is detected when the rotation speed of the torque shafts measured at APPUs is too high. An overspeed is usually due to a PCU mechanical rupture. The detection is made with the LH and RH APPUs.

Uncommanded movement monitoring:

- An uncommanded movement is detected by the FPPU. It can occur when a PCU POB is jammed open or there is a free-wheel in the PCU differential gearbox (mechanical failure).

Slat system jamming:

- A PCU jamming is detected by the SFCCs that monitor the PCU transmission speed with the FPPU. A PCU jamming is detected when the speed is below a specified threshold.

The slat transmission jamming is detected by the TSUs, to protect transmission (and PCU) against damage.

In case of jamming, SFCCs perform a PCU shut-down. The power-off and pressure-off brakes are applied. A recycle operation will be demanded by procedures (flight and maintenance).



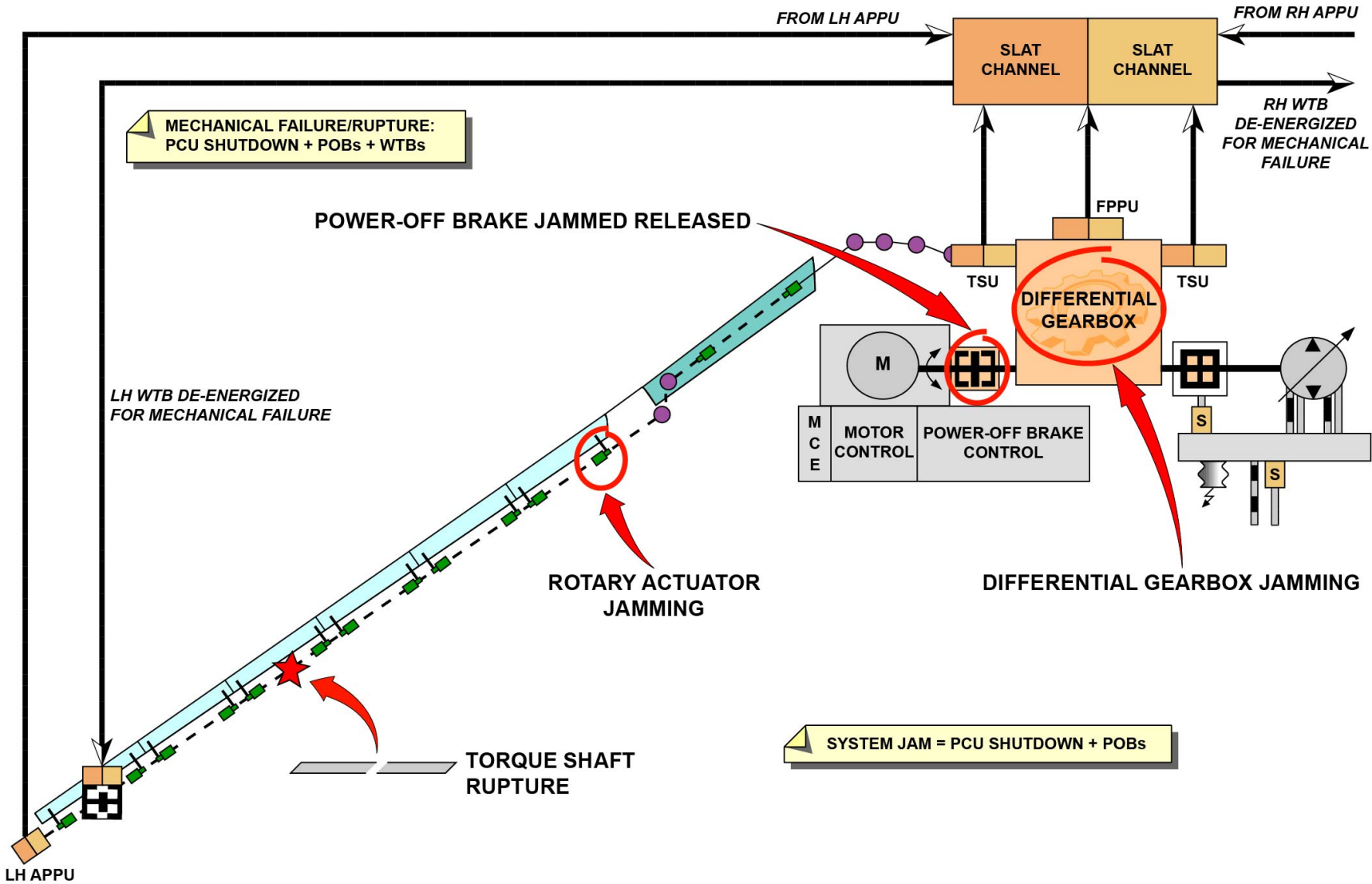

**TRANSMISSION GROUP FAILURES**

V1813401 - V01T0M0 - VM27D9SLATS3001

## FLAPS DESCRIPTION (3)

### Computation Group

#### Flap system description

The flap system includes:

- A slat/flap control lever
- The flap channels of the Slat Flap Control Computers (SFCCs):
  - SFCC1 flap channel
  - SFCC2 flap channel.
- A flap Power Control Unit (PCU)
- Two Active Differential Gearboxes (ADGBs)
- Transmission components (e.g.: bevel gearboxes, transmission shafts)
  - Flap geared rotary actuators
  - Wing Tip Brakes (WTBs)
  - Transmission sensors:
    - A Feedback Position Pick-off Unit (FPPU)
    - Differential Feedback Position Pick-off Units (DFPPUs)
    - Outboard Transmission Speed Sensor Units (OTSSUs).
    - Surface sensors:
      - Station Position Pick-off Units (SPPUs)
      - Load Sensing Drive Struts (LSDSs).

The system drive command comes from the slat/flap lever input if a manual command is applied. The signals go to the SFCCs. The automatic drive commands can also be done by the SFCCs under special conditions (performance optimization).

The flap PCU includes two hydraulic motors.

The flap PCU motors operate the transmission in relation with the signals transmitted by the SFCCs flap channels.

The two motors are active during normal flap operation (active/active concept: speed summing). The PCU operates the transmission components through a differential gearbox. The Pressure-Off Brakes (POBs) are installed on the PCU. They hold the motors in position during a normal operation or in case of specific failures.

The flap PCU operates the flap transmission with:

- Transmission torque shafts which are used to transmit the PCU torque to the drive stations and also to compensate the wing flexion.
- Bevel gearboxes which are used to change the direction of the flap transmission.
- Geared rotary actuators which are installed at each drive station (2 per flap surface). They are used to change the transmission rotation into the flap surface deflection.

The system torque limiters, installed downstream of the PCU output shafts, lock the transmission if there is an excessive torque.

The ADGBs are complementary actuation sources for the flap system, installed between the inboard and outboard flaps. They are controlled and monitored by the SFCCs. The ADGBs can operate the outboard flaps independently from the inboard flaps for differential flap setting functions.

Each ADGB has:

- An electrical motor
- A power-off brake
- A Motor Control Electronic (MCE).

The flap system and/or surface positions are sent to the flap channels of the SFCCs for control and monitoring through different types of sensors:

- A FPPU for the system position feedback from the PCU
- DFPPUs for the system position feedback from the ADGBs
- OTSSUs for the system speed feedback at each end of the transmission (LH and RH wings)
- SPPUs give the flap surface positions at each drive station.



Moreover, at drive station 1 (inboard flaps) and 4 (outboard flaps), the LSDSs are used as drive struts and monitor the loads transmitted to the flap surfaces.

The basic function of the WTB is to lock and to hold the system if there is specific failure.

The WTB are applied in case of:

- Mechanical failure or rupture
- Electrical total power loss or shut down.

The WTBs are also used to operate the inboard and outboard flaps independently (called differential flap setting) at some specific flight phases.

-  GEARED ROTARY ACTUATOR: DRIVE STATION
-  BEVEL GEARBOX
-  SENSOR

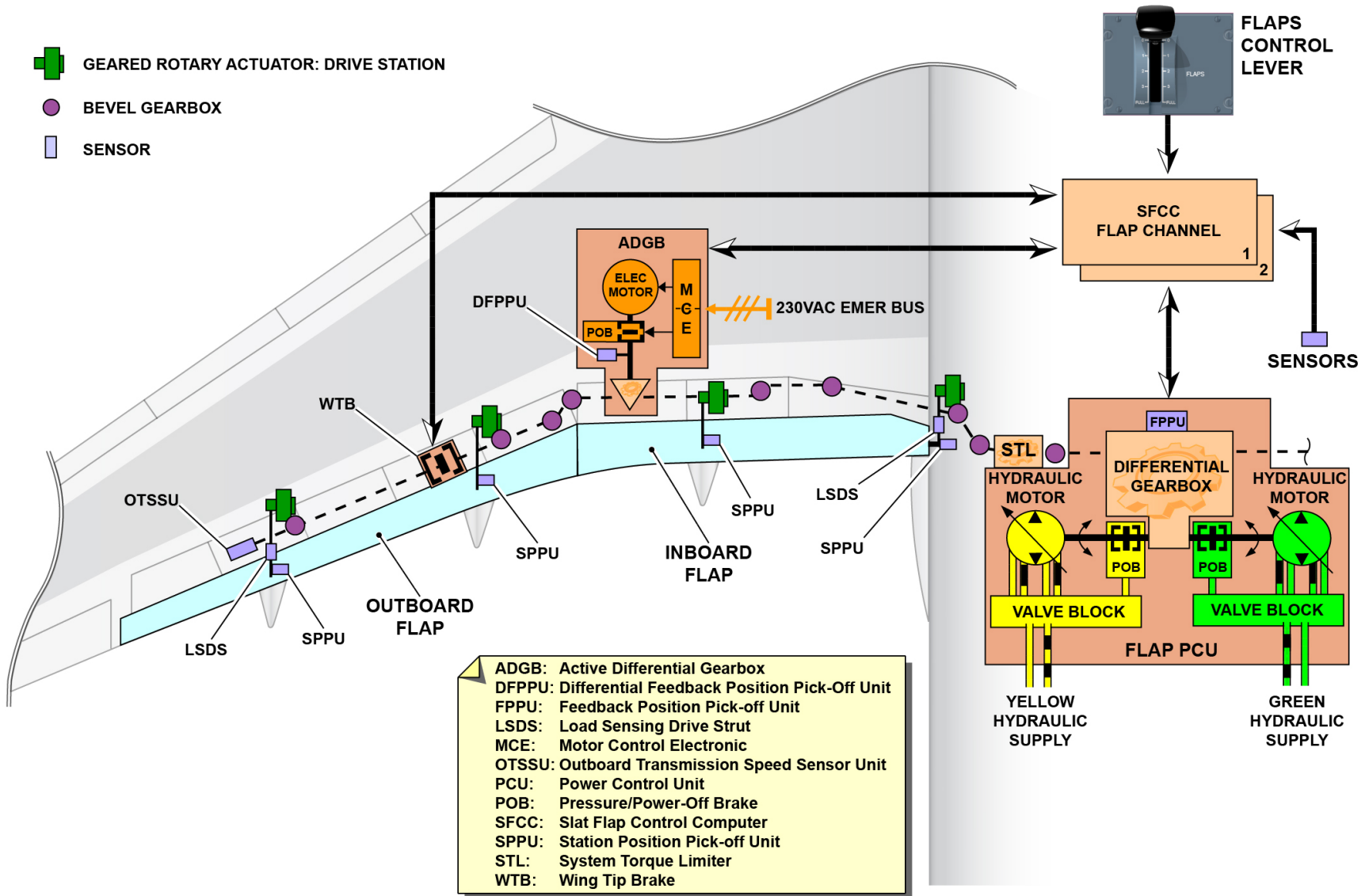

COMPUTATION GROUP - FLAP SYSTEM DESCRIPTION

V1813401 - V01TOM0 - VM27DAFLAPS3001

This Page Intentionally Left Blank

## FLAPS DESCRIPTION (3)

### Computation Group (continued)

#### Flap system control

The SFCCs flap channels calculate the flap-system drive commands, based on:

- The slat/flap lever input (manual control function)
- Inputs from the Air Data/Inertial Reference System (ADIRS) (automatic control and protection function).

In order to optimize the A/C performances in cruise, the two flap channels also receive the flap positioning commands from the Primary Flight Control System (PFCS) for the drag control and wing-bending relief functions.

Note: the automatic and differential flap setting function commands from the ADIRS and the PFCS are developed in the A/C performance module.

#### Flap PCU control

When the SFCC flap channels are energized and when there are no failure, the WTB solenoids are energized (brakes released). If energized, only one of the two solenoids is sufficient to release the WTB.

The WTB solenoids will be de-energized (brakes applied) in case of a critical failure or, as necessary, during differential flap setting operation.

A new target position is calculated by the SFCCs based on the comparison between:

- The inputs from the lever position (from Command Sensor Units (CSUs))
- The current flap position,

The SFCCs create a driving sequence to operate the flap system.

Each flap channel controls its own PCU motor and POB independently from the SFCC flap channel. The SFCC1 flap channel controls and monitors the Yellow hydraulic side. The SFCC2 flap channel controls and monitors the Green hydraulic side.

A cross talk allows the transfer of data between the SFCCs:

- To compare the computation results
- For monitoring functions
- For failure detection
- For validation.

The PCU operates as follow:

- (1) Each SFCC sends a PCU enable signal to the enable solenoid valve to pressurize their related hydraulic valve block.
- (2) Each SFCC sends a POB release signal to their related brake solenoid valve.
- (3) Each SFCC sends speed command signals to their related Electro-Hydraulic Servo Valve (EHSV) to control the hydraulic motor speed and rotation direction.

The hydraulic motors move the transmission through a differential gearbox.

During a uniform flap setting operation (inboard and outboard flap surfaces moving together), the ADGBs work only as a transmission gearbox. They only transmit the torque and speed from the PCU to the outboard flaps. In this configuration, the two ADGB power-off brakes are de-energized (brakes applied, electrical motors not operating).

FLAP PCU CONTROL:  
RH PCU SIDE SHOWN AS EXAMPLE.

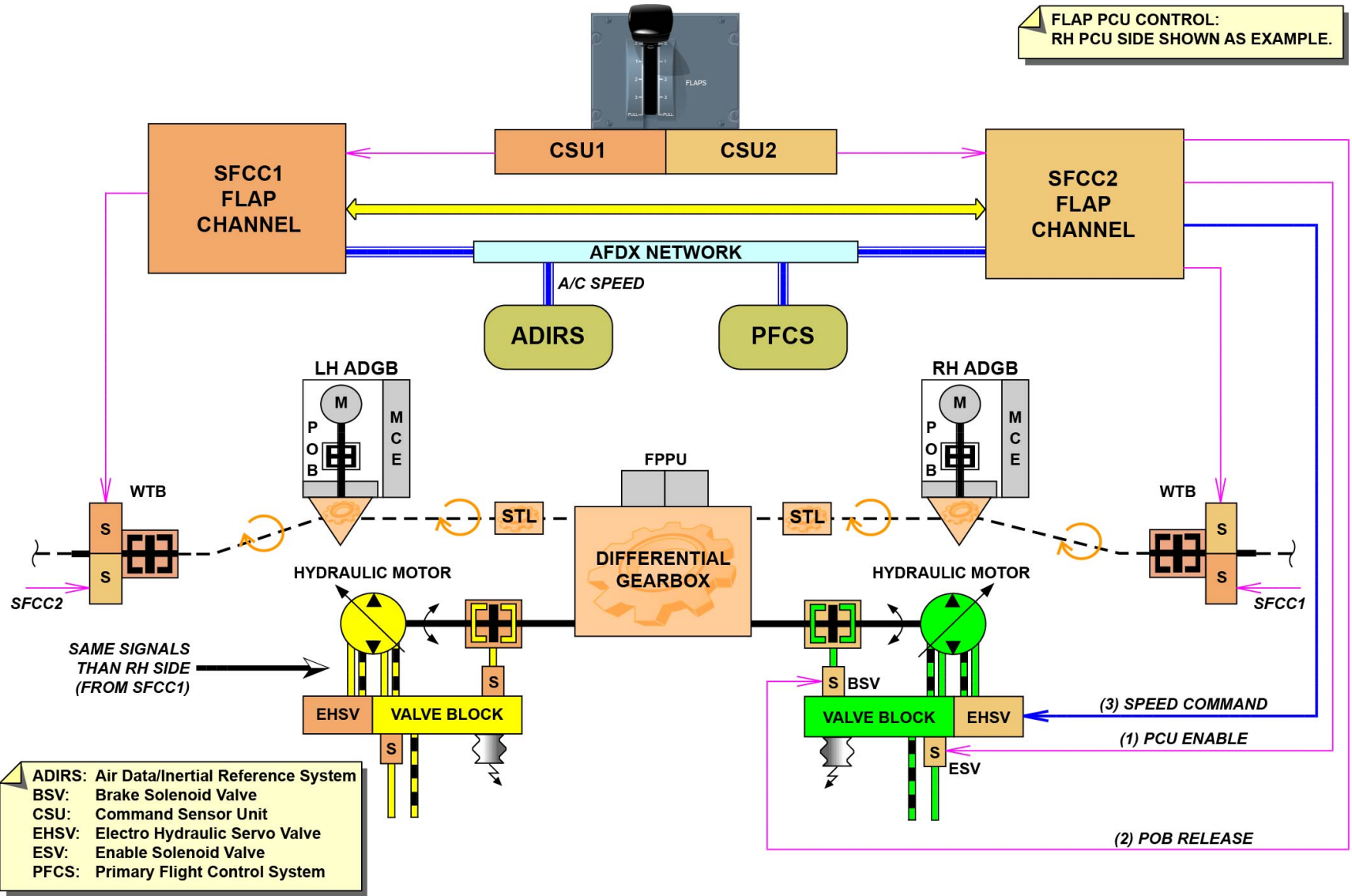

ADIRS: Air Data/Inertial Reference System  
BSV: Brake Solenoid Valve  
CSU: Command Sensor Unit  
EHSV: Electro Hydraulic Servo Valve  
ESV: Enable Solenoid Valve  
PFCS: Primary Flight Control System

COMPUTATION GROUP - FLAP SYSTEM CONTROL

V1813401 - V01T0M0 - VM27DAFLAPS3001

## FLAPS DESCRIPTION (3)

### Computation Group (continued)

#### **ADGB control: differential flap setting introduction**

The ADGBs are part of the flap actuation system. If necessary, they are used to operate the outboard flaps independently from the inboard flaps (differential flap setting).

The SFCCs calculate a new target position based on the comparison between:

- The input data from the lever, the ADIRS, PFCS
- The inboard and outboard flap-position.

Then, the SFCCs control the inboard and the outboard flaps independently or together.

Based on the necessary required configuration:

- The PCU POBs and the WTBs are applied or released.
- The PCU or the ADGBs operate the transmission.

Each WTB has two solenoids. One is connected to SFCC1 and the other to SFCC2. If energized, only one of the two solenoids is sufficient to release the WTB.

To demonstrate the ADGB function, we use the example that follows:

- On ground, if the slat/flap lever is selected to position 1, the SFCC flap channels control an extension of the inboard and outboard flap sections to the same angle setting (10.5°) called uniform flap setting, then the PCU is stopped.
- Then the SFCC2 flap channel controls an additional outboard flap extension to a different setting (13.5°) called outboard differential flap setting. The ADGBs are used as a source of actuation.

The 230VAC EMER 2 supplies the MCE with electrical power.

The SFCC2 flap channel has full authority on the LH and RH ADGBs by controlling the power-off brakes and electrical motors:

- (1) The SFCC2 sends an enable signal to the MCE
- (2) The SFCC2 sends a power-off brake release signal to the MCE, and then the MCE energizes the power-off brake

- (3) The SFCC2 sends a speed command to the MCE, and then the MCE gives an analog signal to the electrical motor to control the speed and the rotation direction of the outboard flap transmission shaft. Under electrical emergency condition, the electrical power consumption of the high-lift system from the Ram Air Turbine (RAT) supply for the slat and flap movements is limited (to 6 Kva) to prevent overload of the RAT. Therefore, the ADGB speed is decreased.



**1+F DIFFERENTIAL FLAP SETTING EXAMPLE:**  
 - CONTROL LEVER TO POSITION 1.  
 - A/C ON GROUND.

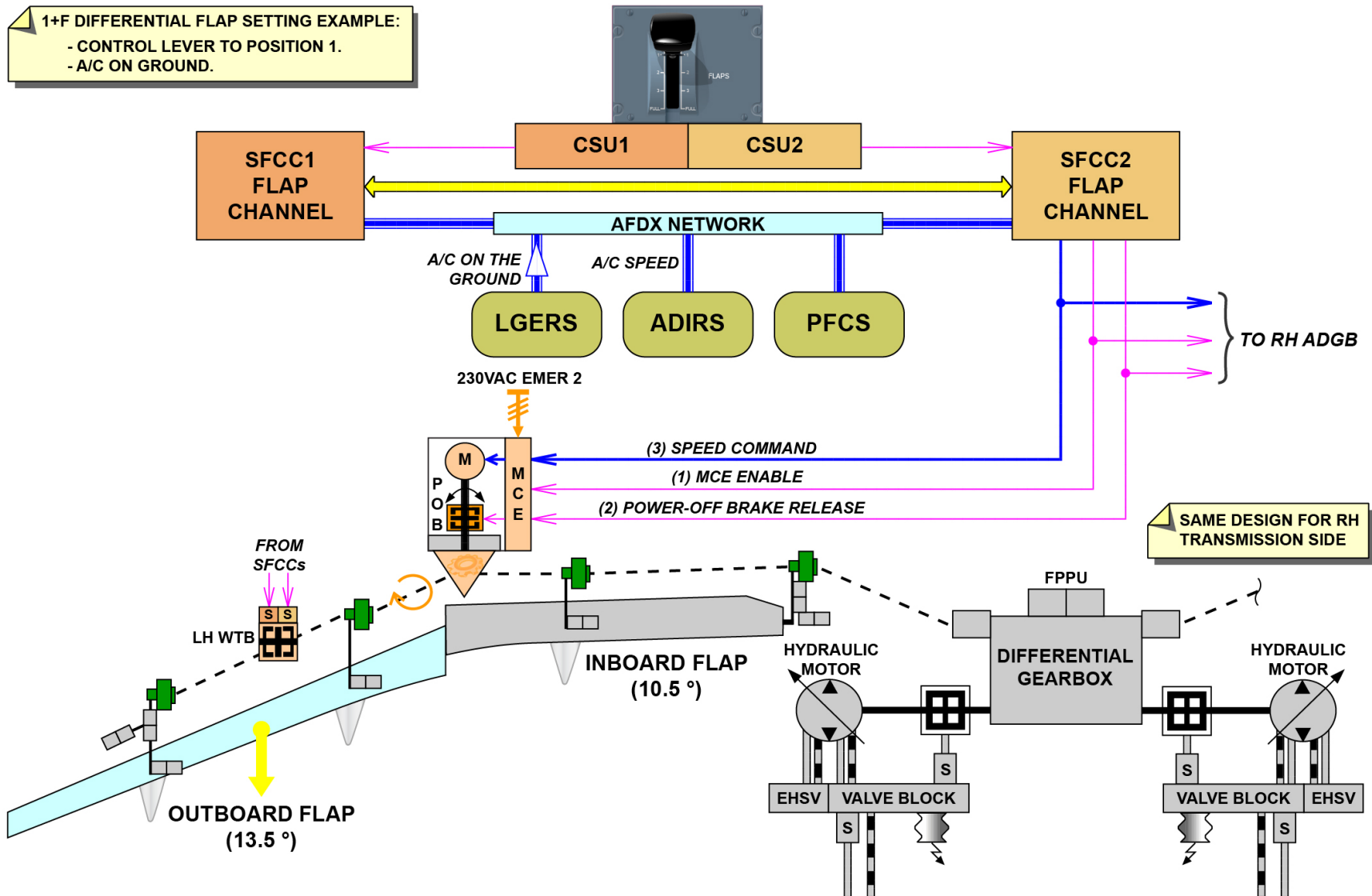

COMPUTATION GROUP - ADGB CONTROL: DIFFERENTIAL FLAP SETTING INTRODUCTION

V1813401 - V01T0M0 - VM27DAFLAPS3001

## FLAPS DESCRIPTION (3)

### Computation Group (continued)

#### Flap system monitoring

The start-up sequence must make sure that each POB is only released at a sufficient pressure. This is monitored with a pressure transducer on each valve block. Each transducer sends data to their related SFCC. The monitoring system is composed by:

- The SFCCs
- Sensors.

These system sensors give a continuously feedback of the flap drive system and of the transmission system to the SFCCs.

A FPPU mounted on the PCU, gives information about the flap PCU actual position to the SFCCs that use this data for the system monitoring (i.e.: uncommanded movement and transmission jamming).

The DFPPUs included in the ADGB, give information about the outboard flaps position to the SFCCs that use this data for the system position monitoring (i.e.: uncommanded ADGB movement, overspeed of inboard flaps during DFS).

The SPPUs installed at each drive station, give information about the system and flaps position to the SFCCs that use this data for the system monitoring (i.e.: asymmetry, flap skew).

The OTSSUs at each outer end of the transmission, give information about the system speed to the SFCCs that use this data for monitoring (i.e.: outboard flap overspeed and transmission jamming).

The LSDSs at each station 1 and 4, give feedback to the SFCCs to monitor the flap load (i.e.: drive strut disconnect).

Each sensor is connected to SFCC1 and SFCC2

Each WTB solenoid is connected to one SFCC flap channel. A proximity sensor in each WTB gives a released or applied status to SFCC1 only.

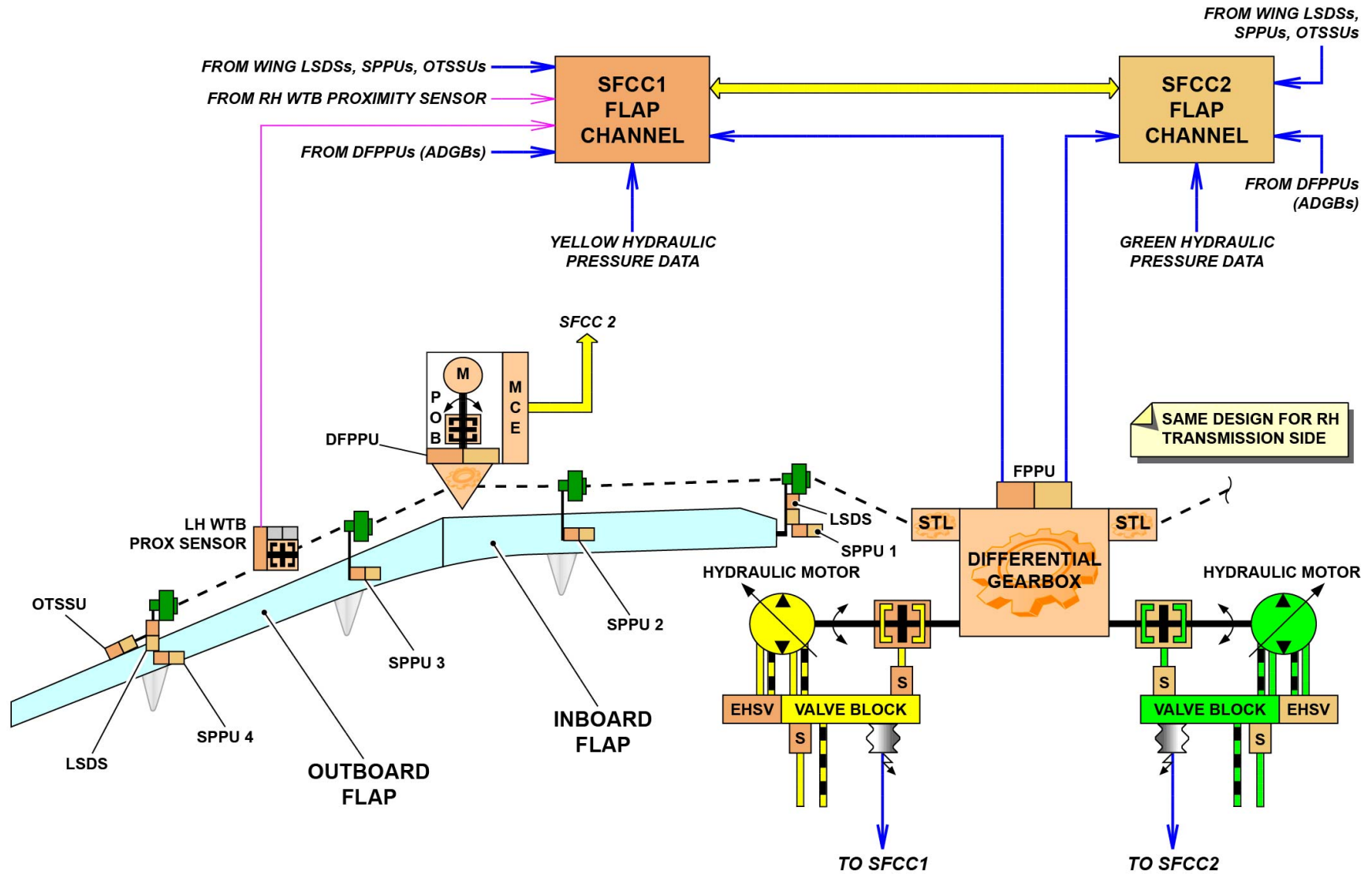

COMPUTATION GROUP - FLAP SYSTEM MONITORING

V1813401 - V01T0M0 - VM27DAFLAPS3001

---

## FLAPS DESCRIPTION (3)

### Flap System Actuation Group

#### Flap PCU

The flap PCU includes these components:

- Two hydraulic control manifolds (also called valve blocks) with:
  - The hydraulic motors
  - The POBs
  - The solenoid valves.
- Two hydraulic motors:
  - One supplied with the Green hydraulic power-circuit
  - The other supplied with the Yellow hydraulic power-circuit.
- Two POB

Each POB is related to a hydraulic motor, and is supplied with the same hydraulic circuit.

- A differential gearbox assembly (speed summing concept)

The differential gearbox assembly transmits the movement from the hydraulic motors to the flap transmission.

- A FPPU installed on the differential gearbox assembly to give the PCU output shaft position.

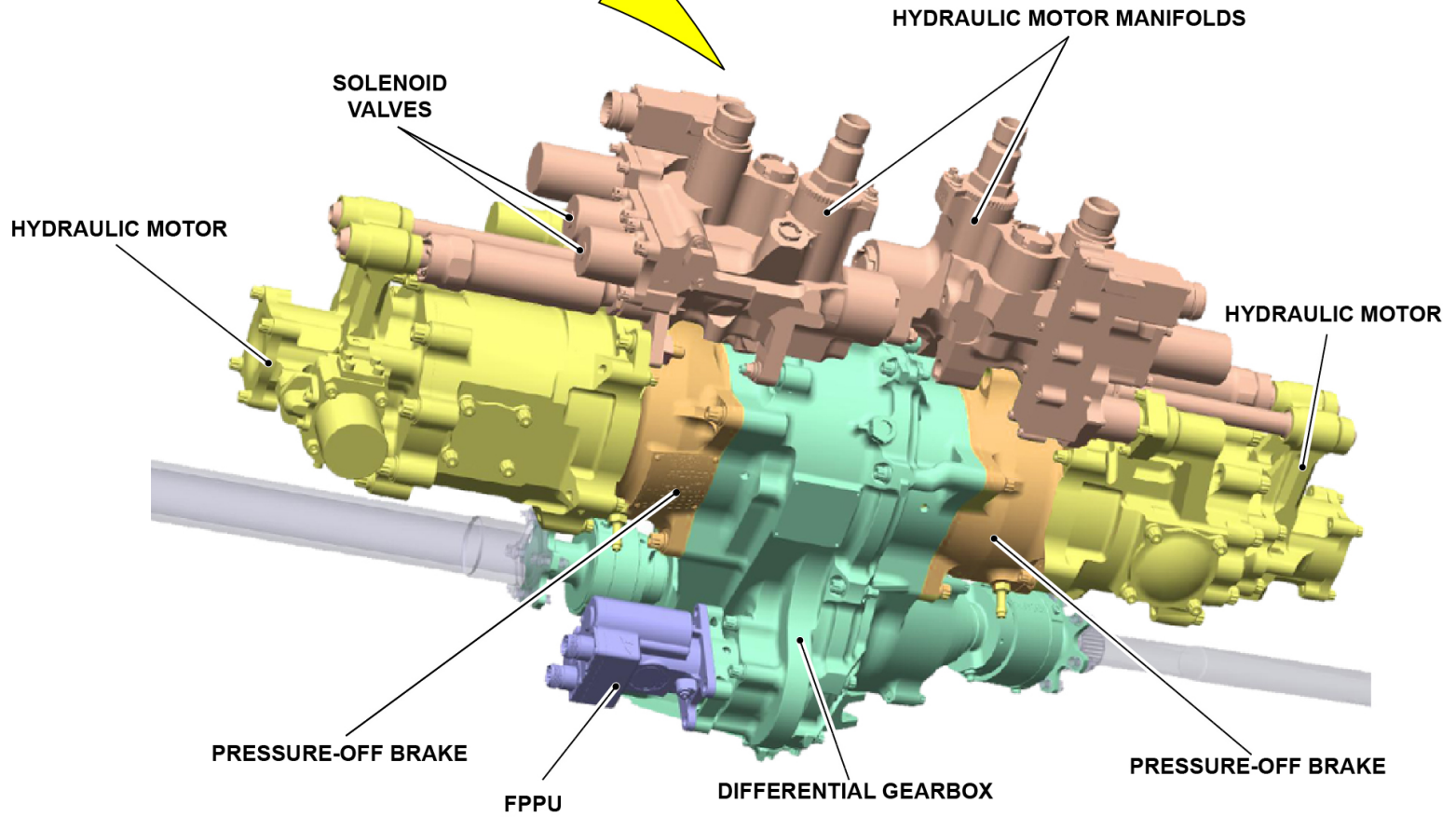
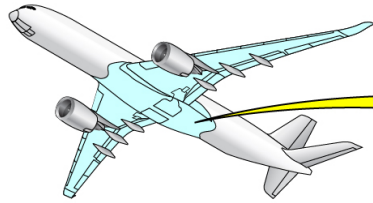

**FLAP SYSTEM ACTUATION GROUP - FLAP PCU**

V1813401 - V01T0M0 - VM27DAFLAPS3001

## FLAPS DESCRIPTION (3)

### Flap System Actuation Group (continued)

#### Active differential gearbox

The Active Differential Gearbox (ADGB) includes the components that follow:

- An electrical motor
- An electrical power-off brake
- A MCE
- A differential gearbox, which is the interface between:
  - The electrical motor
  - The electrical power-off brake
  - The flap transmission shaft (from the inboard flap to the outboard flap)
- , and
- A DFPPU, that gives outboard flap-position data to the SFCC flap channels.

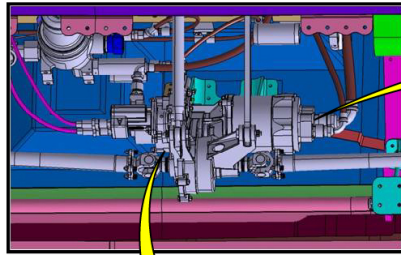

TOP VIEW (LH WING)



MCE

POWER-OFF BRAKE

TO DRIVE STATION 2  
(INBOARD FLAP)

DFPPU

DIFFERENTIAL  
GEARBOX

ELECTRICAL  
MOTOR

TO DRIVE STATION 3  
(OUTBOARD FLAP)

BOTTOM VIEW (LH WING)

ELECTRICAL  
MOTOR

UPPER ATTACHMENTS

POWER-OFF BRAKE

DIFFERENTIAL  
GEARBOX

LOWER ATTACHMENTS

RIGGING  
WINDOW

DFPPU

FLAP SYSTEM ACTUATION GROUP - ACTIVE DIFFERENTIAL GEARBOX

V1813401 - V01T0M0 - VM27DAFLAPS3001

## FLAPS DESCRIPTION (3)

### Flap System Transmission Group

#### Geared rotary actuators

A flap geared rotary-actuator is mounted on the fixed support beam (part of the A/C structure) at each drive station.

The geared rotary actuators role is to change the torque power of the flap system transmission into torque output for the flap movement.

The geared rotary actuators have a different design. They are installed:

- At drive station 1.
- At drive station 2. The geared rotary actuator includes a torque limiter to give protection to the flap transmission system against overloads. Its torque limiter indicator can be used for troubleshooting functions after a system jam.
- At drive station 3 and 4.

The geared rotary actuators are lubricated with fluid and can be drained and refilled on ground through related plugs. The actuator is filled with semi-fluid lubricant.

A fifth station is located at the outboard side of the outboard flap section. The function of the non driving station 5 is to guide the flap section during operation.



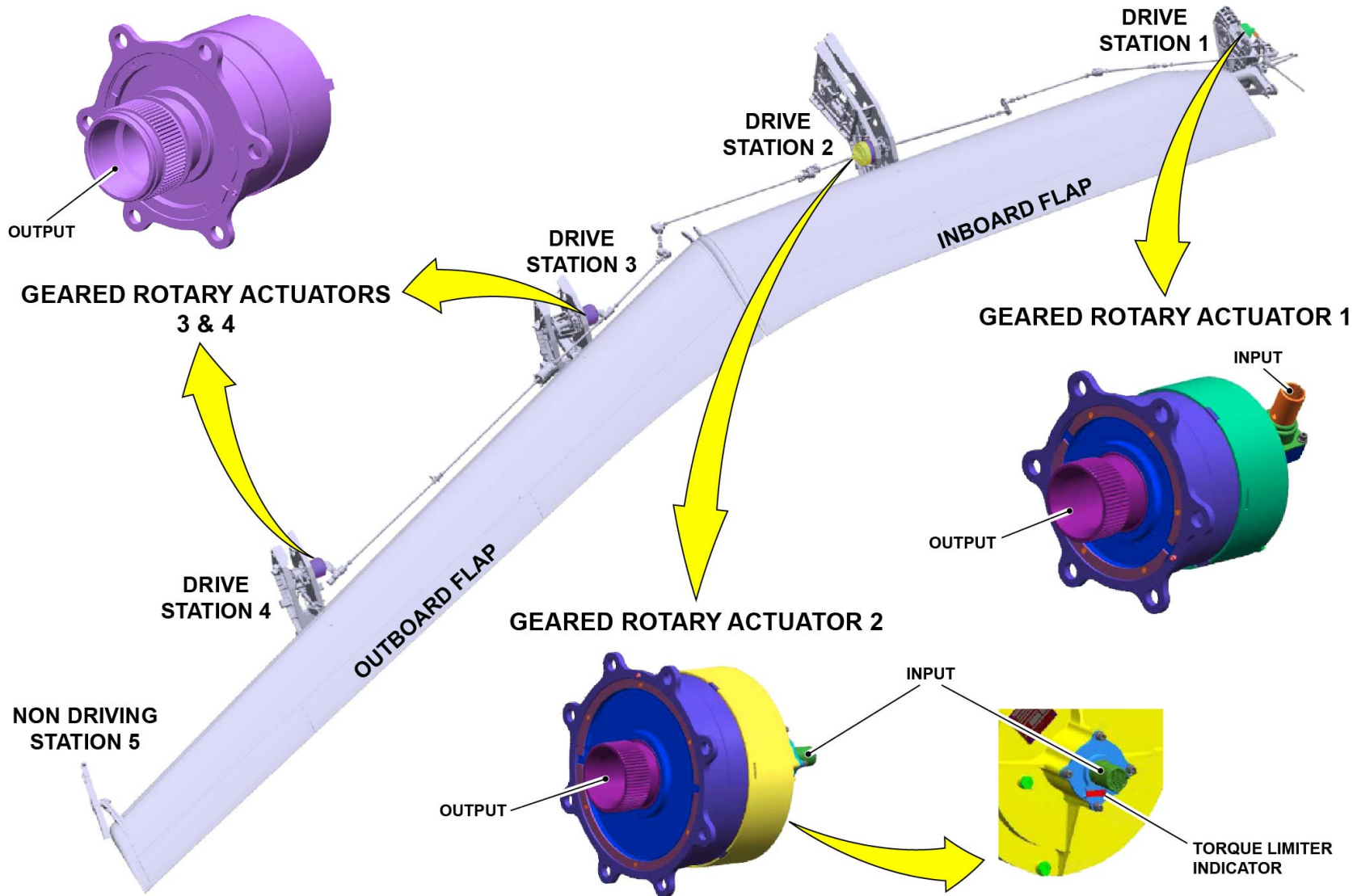

FLAP SYSTEM TRANSMISSION GROUP - GEARED ROTARY ACTUATORS

V1813401 - V01T0M0 - VM27DAFLAPS3001

## FLAPS DESCRIPTION (3)

### Flap System Transmission Group (continued)

#### Torque limiters

Two system torque limiters (LH and RH) are installed downstream of the flap PCU. They are used to protect the flap transmission against overloads (by transfer of the PCU output torque to the fuselage structure).

During a reverse operation (recycle) if the torque level decreased below a setting value, the system torque limiter unlocks automatically and the system is operative. A system torque-limiter lockout is shown by a mechanical indicator on the component, which can only be reset on ground. The indicator is used to locate the defective side during troubleshooting.

Each drive station has a station torque limiter installed on the bevel gearboxes, which makes sure that the system is stopped if there is a jamming or a high friction that comes from the flap drive station. They operate like system torque limiters and can only be reset on ground. The indicator is used for troubleshooting functions.

#### WTB

A WTB is installed downstream of each ADGB.

The primary function of the WTB is to lock the flap transmission in case of specific failures (e.g.: shaft disconnection).

The WTBs are also used to operate the inboard and outboard flaps independently (called differential flap setting) at some specific flight phases.

Each WTB has a proximity sensor that gives its released or applied status to SFCC1.

For maintenance functions, each WTB includes a manual release device.

#### Moving damper

A moving damper is installed parallel to the drive strut, between the fixed support of station 2 and the flap hinged lever.

It is a secondary load-path. It is used to prevent loads that are too high to the drive station 1 if there is a special failure scenarios (e.g. rupture of the drive strut at the support station 2). It includes a cylinder and an oil accumulator.

The moving damper has two operating modes:

- Normal mode: extension and retraction operated with the inboard flap movement
- Failure mode: moving damper retraction with high velocity (after a disconnection of flap drive station 2).

The monitoring of the flap moving damper is done with a Linear Variable Differential Transducer (LVDT) located on the oil accumulator. The sensor is connected to the SFCC for the fluid level and movement monitoring that guarantees the detection of all related hidden failures.

A tension fuse prevents the moving damper from jamming in high friction cases. The fuse rupture will cause a moving damper disconnection, detectable by the LVDT.

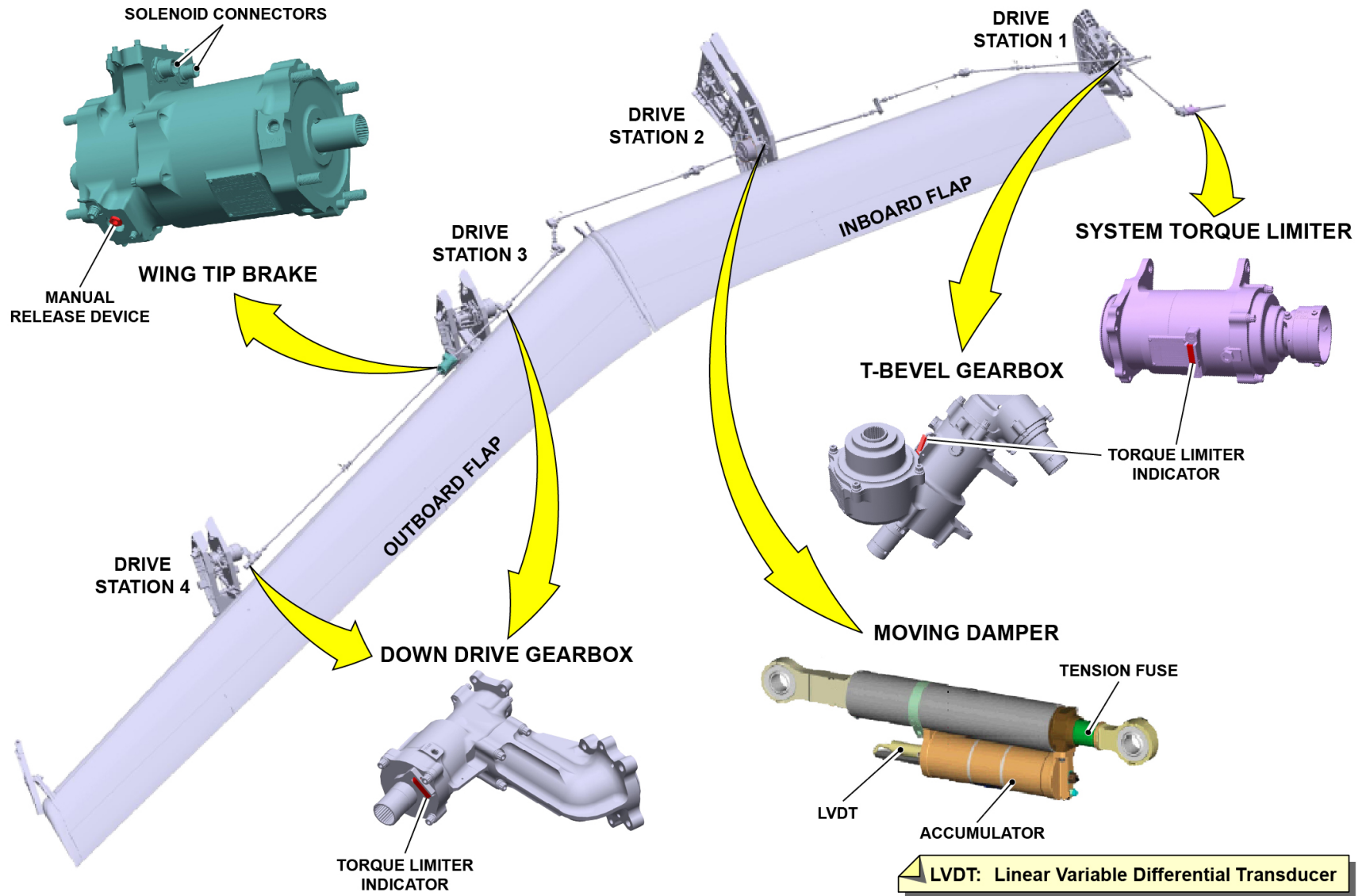

**FLAP SYSTEM TRANSMISSION GROUP - TORQUE LIMITERS ... MOVING DAMPER**

V1813401 - V01T0M0 - VM27DAFLAPS3001

## FLAPS DESCRIPTION (3)

### **Flap Surface Kinematic Description**

The flap movement is done around a pivot point on the fixed support beams.

The flap is connected to this pivot point through the flaps lever, and is operated by a geared rotary actuator through a drive strut. This arrangement, called flap drive station, is numbered from 1 (at the fuselage or wing junction level) to 4 (for the most outboard station).

The droop panels and spoilers follow the flap movement to ensure fulfillment of the gap or overlap requirements between the wing trailing edge and the flap leading edge.

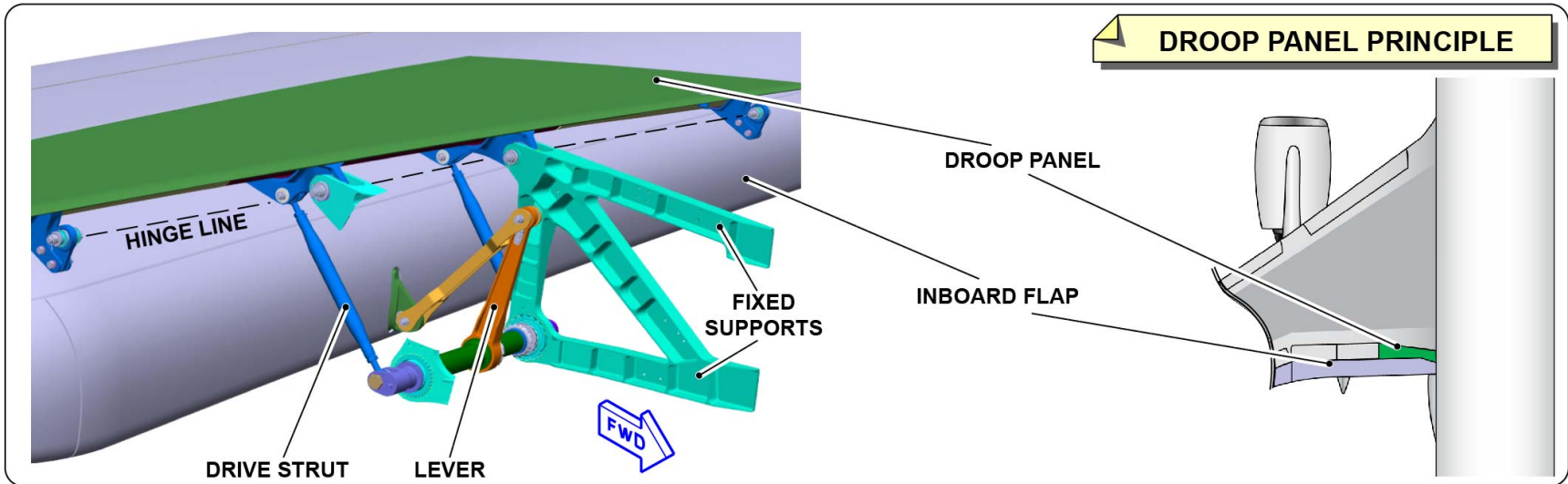
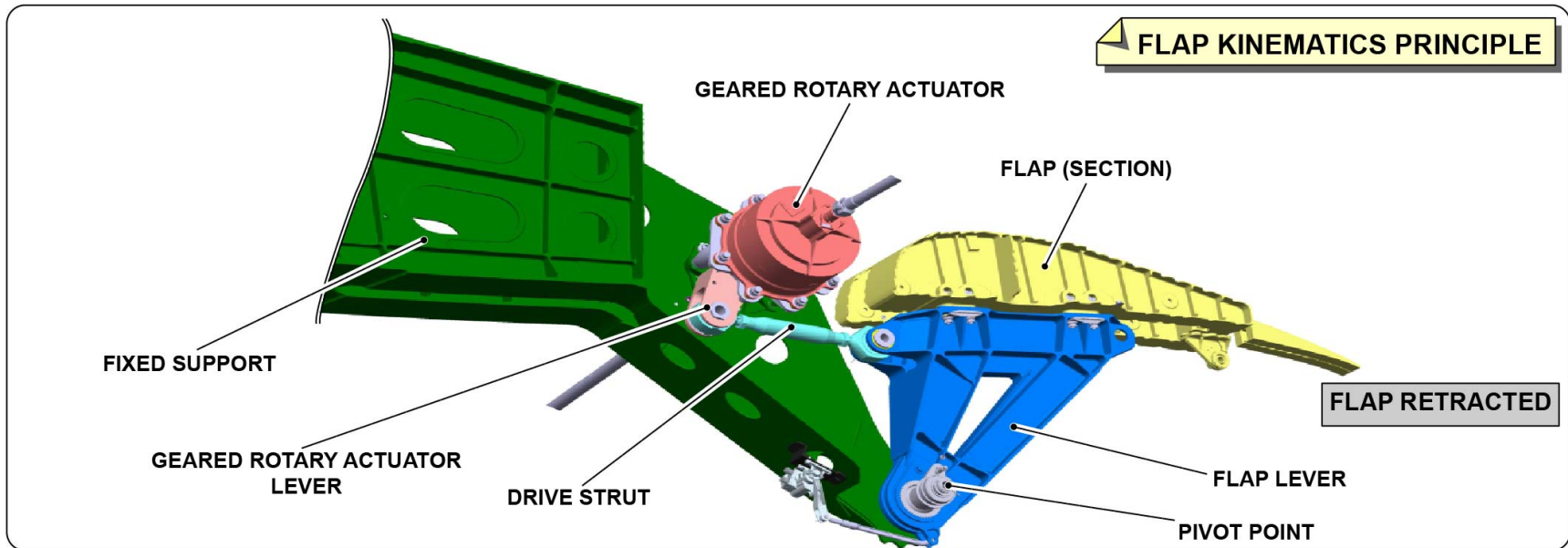

FLAP SURFACE KINEMATIC DESCRIPTION

V1813401 - V01T0M0 - VM27DAFLAPS3001

## FLAPS DESCRIPTION (3)

### Flap System Sensors Description

The flap drive-system positions, speeds and loads are continuously monitored by the flap channels of the SFCCs with the following sensors:

- A FPPU which is installed on the flap PCU output (qty 1)
- DFPPUs which are installed on each ADGB (qty 2)
- OTSSUs which are installed on the end of the transmission on each wing (qty 2)
- SPPUs which are installed on the each flap drive station (qty 8)
- LSDSs which are installed on each drive station 1 and 4 (qty 4)

The FPPU are used to measure the angular position and the rotation speed of the transmission. A zero indication window (rigging window) is installed on the FPPU for adjustment purposes.

The SPPU and OTSSU sensors are operated by the same input shaft.

The SPPUs are used to give the angular position of the flap hinged lever.

The DFPPU sensors are used to measure the angular position and rotation speed of the outboard flap transmission. A zero indication window (rigging window) is installed on the DFPPU for adjustment purposes.

The OTSSUs are used to give the rotation speed of the transmission shaft.

The LSDSs act as a drive struts, and are used to monitor the load value at each drive stations 1 and 4. The LSDSs are used to detect an overload if there are kinematic failures or ruptures.

All these sensors are connected to the SFCC1 and SFCC2 flap channels to provide a monitoring redundancy and dual logic failure detection.



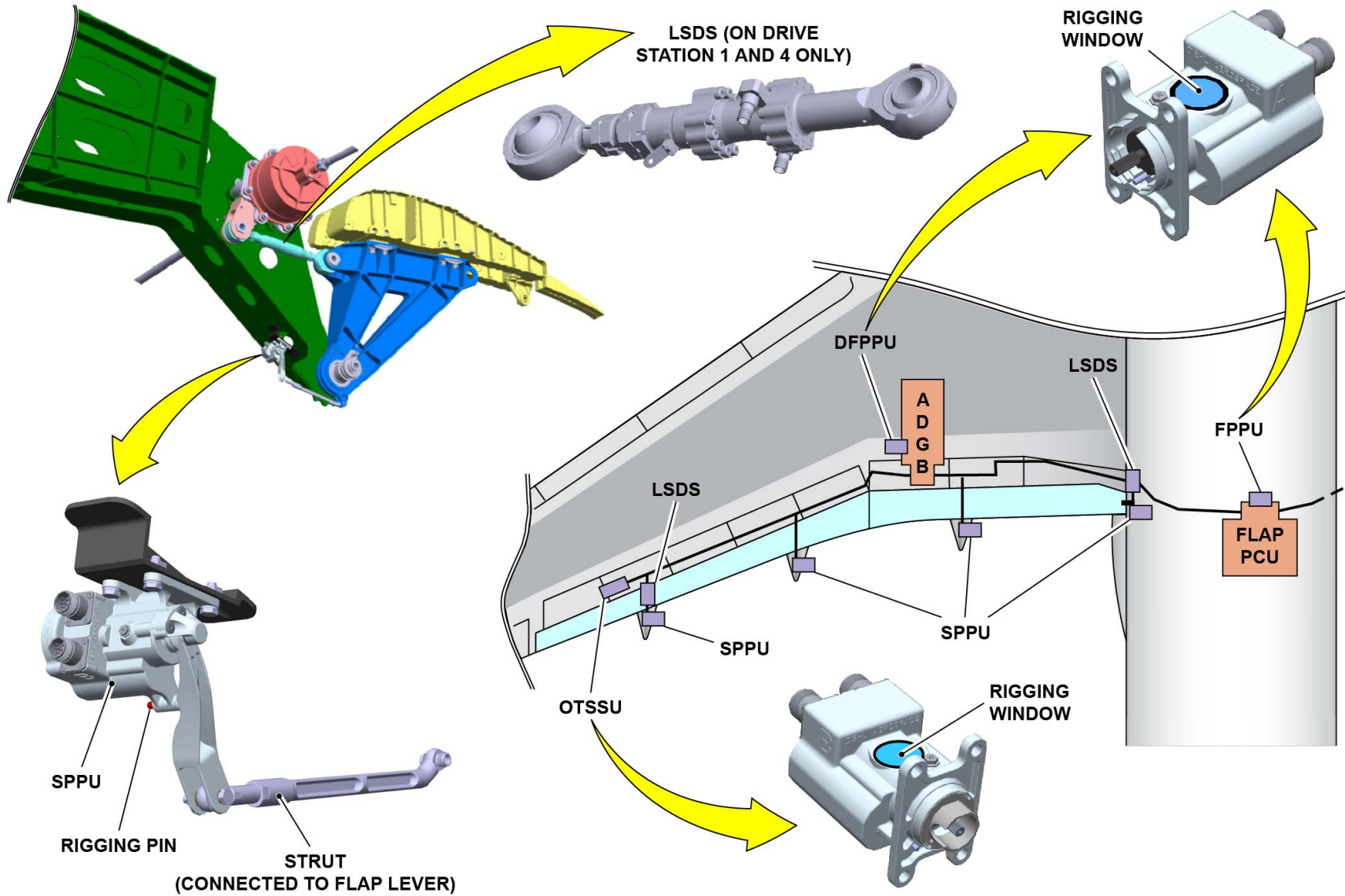

**FLAP SYSTEM SENSORS DESCRIPTION**

V1813401 - V01T0M0 - VM27DAFLAPS3001

---

## FLAPS DESCRIPTION (3)

### Flap System Abnormal Configurations

#### Half speed configuration

A half speed configuration is engaged if there is:

- A loss of one SFCC slat channel
- A loss of the one hydraulic power (or hydraulic power not available).

If one SFCC flap channel has a failure or one hydraulic supply is not available, its related PCU motor stops and its POB is applied. The operation is possible only at half speed using the other flap channel and hydraulic motor



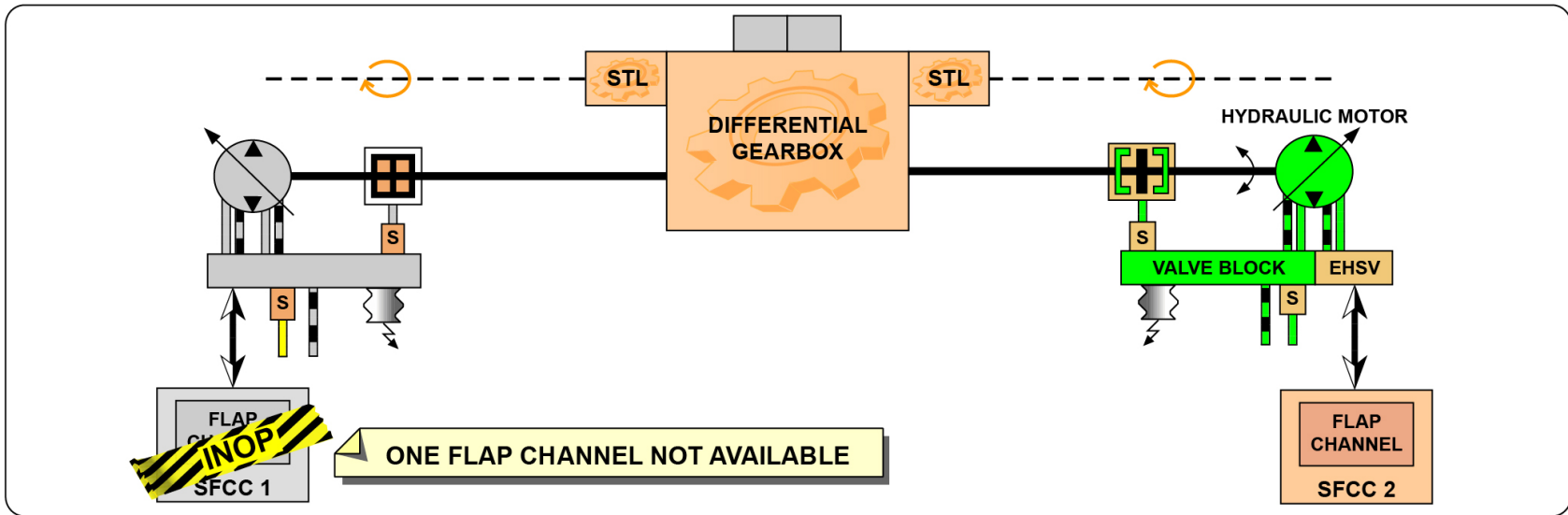

**HALF SPEED**

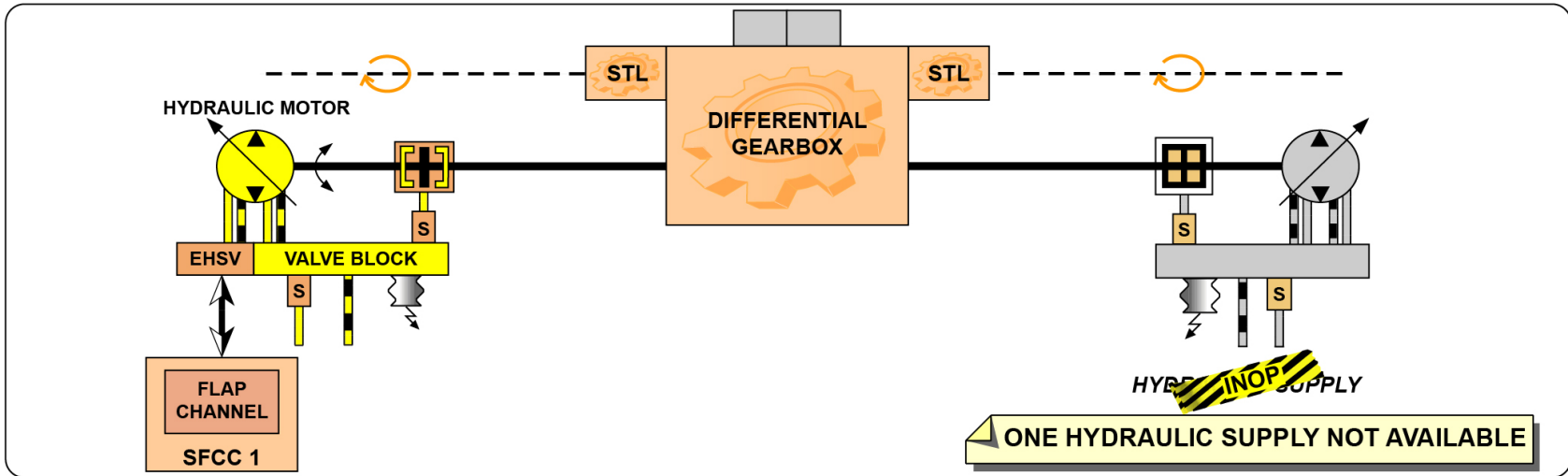

FLAP SYSTEM ABNORMAL CONFIGURATIONS - HALF SPEED CONFIGURATION

V1813401 - V01T0M0 - VM27DAFLAPS3001

---

## FLAPS DESCRIPTION (3)

### Flap System Abnormal Configurations (continued)

#### **Outboard flaps setting, uniform flaps setting**

If both flap PCU motors are inoperative (due to a total loss of both hydraulic systems, PCU faults, loss of control, etc.), the SFCC2 can only control the outboard flaps (moved by the ADGBs).

If there is a SFCC2 flap channel or an ADGB motor failure that leads to the loss of the outboard differential flap-setting, the flap system operates with an uniform flap setting (inboard and outboard flap section move together).

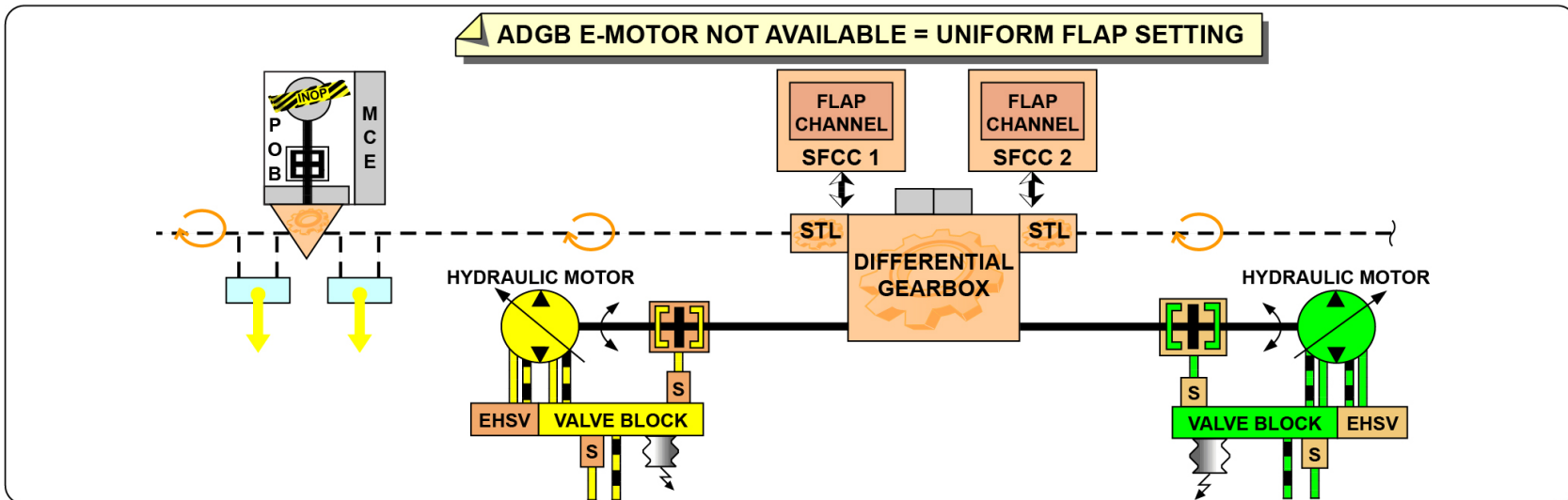
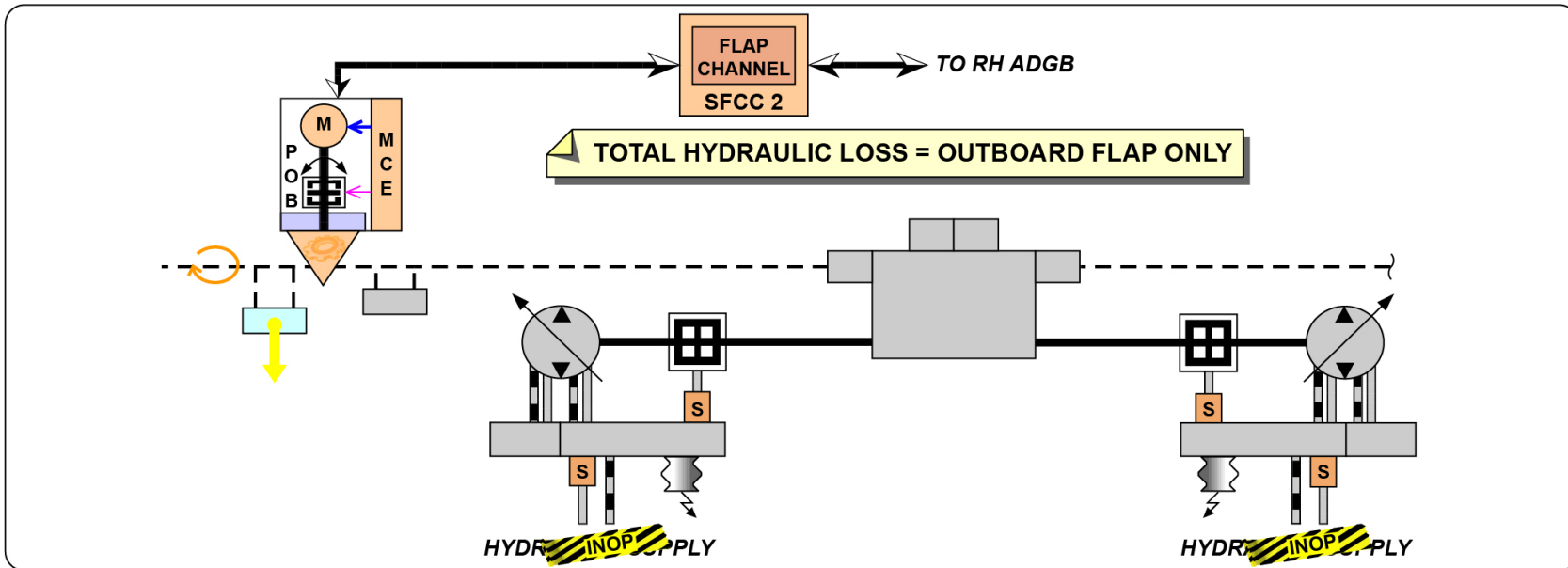

FLAP SYSTEM ABNORMAL CONFIGURATIONS - OUTBOARD FLAPS SETTING, UNIFORM FLAPS SETTING

V1813401 - V01T0M0 - VM27DAFLAPS3001

## FLAPS DESCRIPTION (3)

### Transmission and Actuation Group Failures

#### Mechanical failures

A mechanical failure (e.g.: transmission shaft or PCU mechanical part) can cause:

- An asymmetry
- An overspeed
- An uncommanded movement.

Consequently, the SFCCs command a PCU shut-down and the POBs and WTBs are applied.

A flap asymmetry can occur between:

- The wings (RH/LH)
- The inboard flaps (RH/LH)
- The outboard flaps (RH/LH).

The asymmetry is a position difference between the LH and RH SPPUs.

The asymmetry is usually due to a broken shaft or an asynchronous movement of the ADGBs.

The detection is made through the LH and RH SPPUs value comparison.

There are two Flap Overspeed cases:

- An inboard flap overspeed, detected when the measured speed at the DFPPUs is too high.
- An outboard flap overspeed, detected when measured speed at the OTSSUs is too high.

This is usually due to a PCU mechanical rupture or a free wheel in the ADGB (mechanical failure).

Inboard and Outboard Flap uncommanded movement:

- An inboard flap uncommanded movement occurs if there is a position difference between the SPPUs and the FPPU.

This can be caused by one PCU POB jammed open or a free wheel of the differential gearbox (mechanical failure).

- An outboard flap uncommanded movement occurs if there is a position difference between the DFPPUs and the FPPU.

This can be caused by an ADGB POB jammed open or ADGB differential gearbox free wheel.

The flap skew is flap panel torsion due to:

- A drive-strut actuator disconnection
- An actuator free wheel
- A rupture of the drive-shaft that connects the two panel drive stations.

A flap skew is detected with a comparison between the SPPUs.

If there is a flap drive strut disconnect, the LSDS are also used to detect a flap skew at station 1 and 4, where the flap loads are too small for a skew detection with the SPPUs.

**MECHANICAL FAILURES:**

- TOTAL PCU/ADGBs SHUT DOWN
- PRESSURE-OFF & POWER-OFF BRAKES APPLIED
- WTBs APPLIED

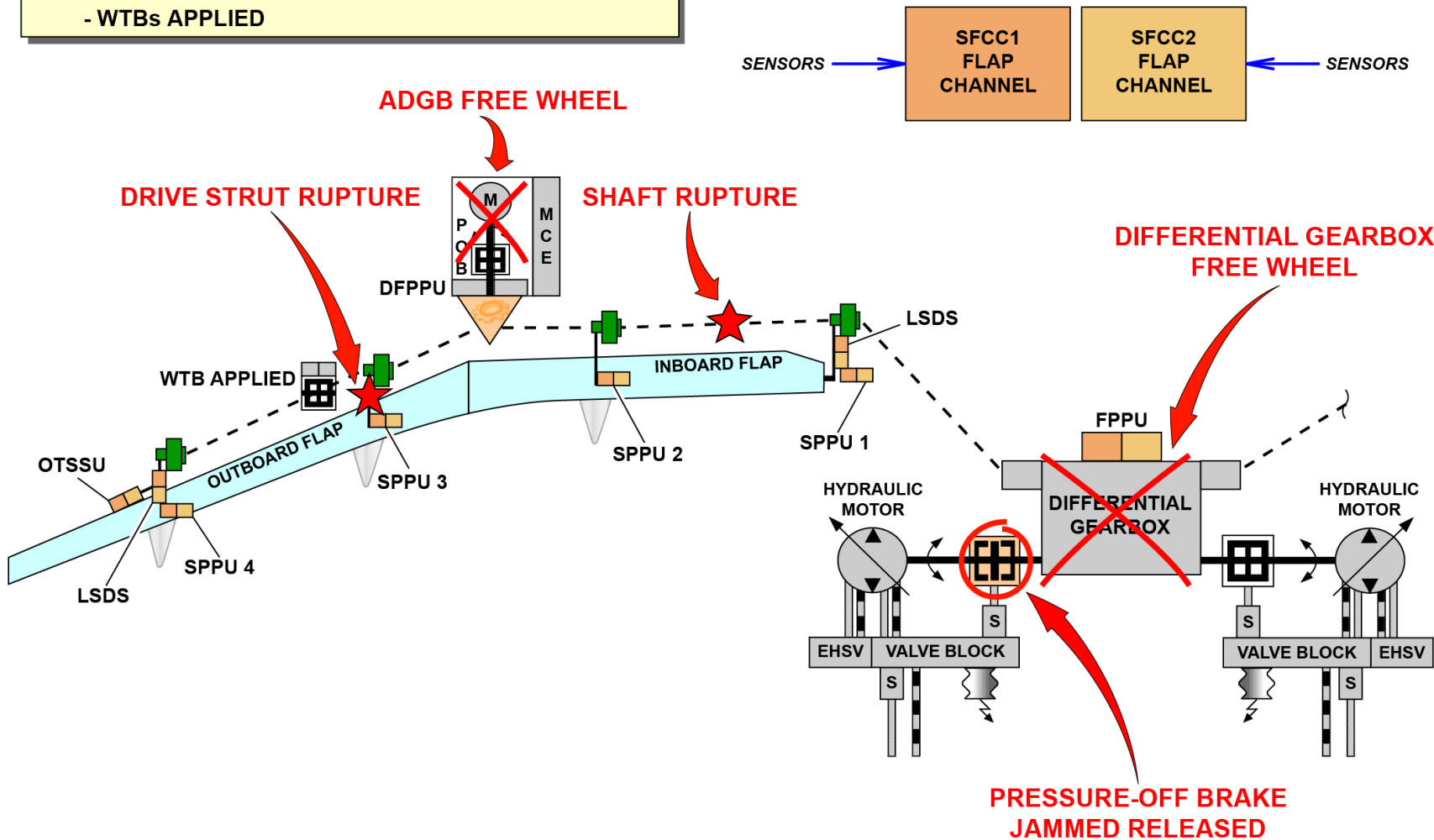

TRANSMISSION AND ACTUATION GROUP FAILURES - MECHANICAL FAILURES

V1813401 - V01T0M0 - VM27DAFLAPS3001

---

## FLAPS DESCRIPTION (3)

### Transmission and Actuation Group Failures (continued)

#### System jamming

Flap system jam monitoring: detected by FPPUs.

In case of jamming, the SFCCs perform a PCU and ADGBs shut-down. The POBs are applied. A "RECYCLE" operation will be demanded by the Procedures (Flight and Maintenance).

The flap transmission is protected against damage by the system torque limiter transmission.

Outboard-system jam monitoring during an outboard differential flap setting:

An outboard flap (LH/RH) system jam is detected through the OTSSUs measurement of the transmission speed. A jam is confirmed if the speed is below a defined threshold. The source of the jam can be the transmission (e.g. geared rotary actuator) or the ADGB (e.g. power-off brake jammed closed).

After an ADGB jam on one side, the ADGB on the other side is also stopped to prevent asymmetric outer flap-deflections.

After a jamming detection, a "RECYCLE" operation will be demanded by the Procedures (Flight and Maintenance).

**SYSTEM JAMMING:**

- TOTAL PCU/ADGBs SHUT DOWN
- PRESSURE-OFF & POWER-OFF BRAKES APPLIED
- RECYCLE PROCEDURE

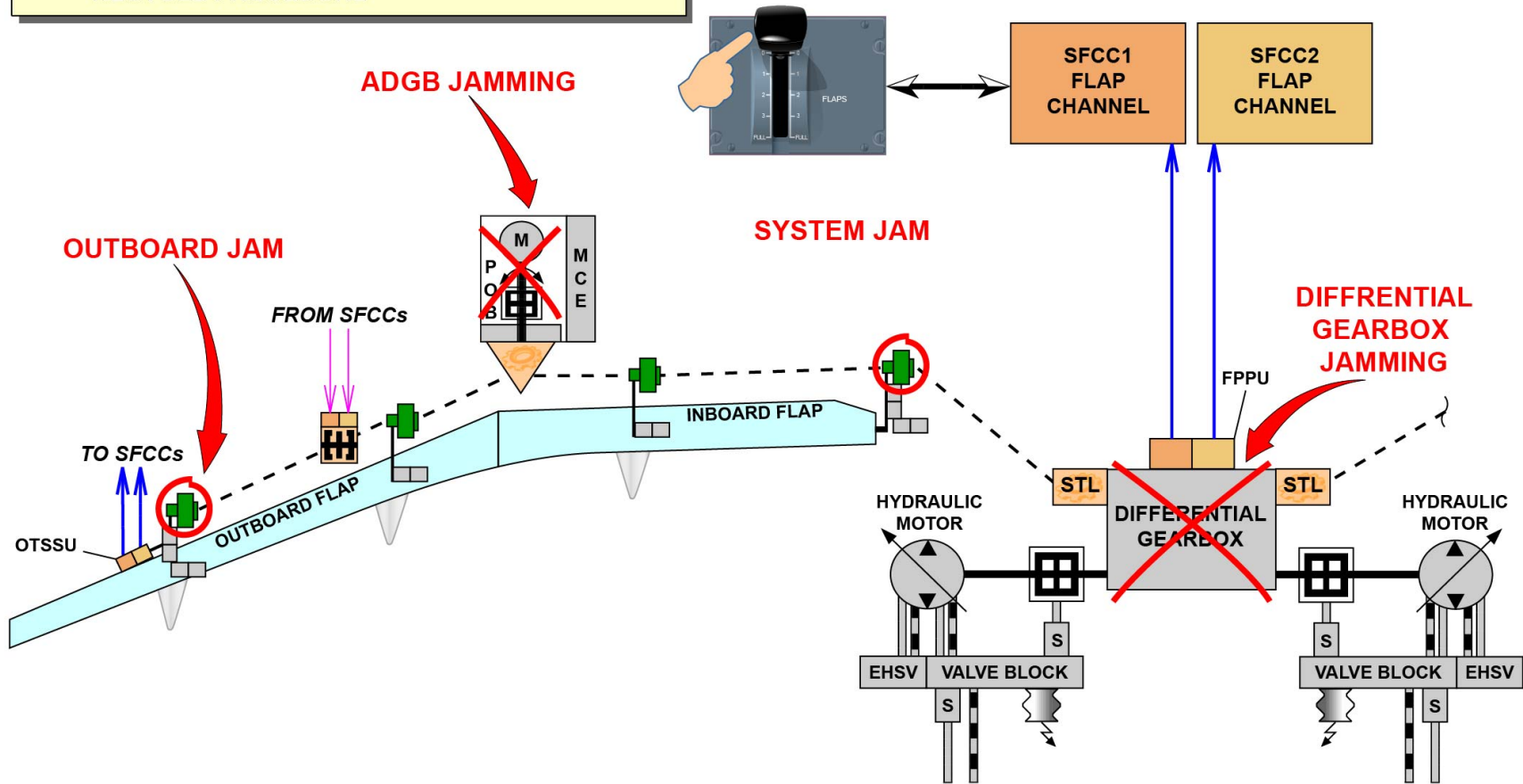

TRANSMISSION AND ACTUATION GROUP FAILURES - SYSTEM JAMMING

V1813401 - V01T0M0 - VM27DAFLAPS3001

---

## AIRCRAFT PERFORMANCE OPTIMIZATION DESCRIPTION (3)

### **Lift and drag management: take-off and landing phases**

The high lift system and high lift devices do the lift and drag management during the take-off and landing phases of a flight in low speed conditions. They also do the management of the climb and cruise phases to optimize the A/C performance.

This topic shows the law computation done by the Slat Flap Control Computers (SFCCs), from a manual command operated with the slat/flap control lever.

The control lever has five positions, from 0 to FULL. The high lift system has seven nominal configurations for normal operation.

The 1+F and 3+S auto-command functions are engaged in relation to the specific A/C configuration, to optimize the lift and drag management.

The relation between the lever position, the slat and flap configurations and the flight phases is shown in the slide table.

The high lift system has different flaps settings for the take-off and landing phases with the FLAPS lever in position 1:

- A/C on ground, during the extension: the configuration 1+F is engaged, but the flaps must be moved to the configuration with the differential flap setting.
- A/C in flight at low speed (or A/C on jacks): the configuration 1+F is engaged without the differential flap setting during the extension.
- For approach (A/C in flight at high speed): only the configuration 1 is engaged during the extension.

The high lift system has two different slat settings for the take-off and landing phases with the FLAPS lever in position 3:

- The slats are commanded to the take-off configuration 3 when A/C is on ground (take-off).
- The slats are commanded to the landing configuration 3+S when A/C is on jacks or in flight (approach, landing).



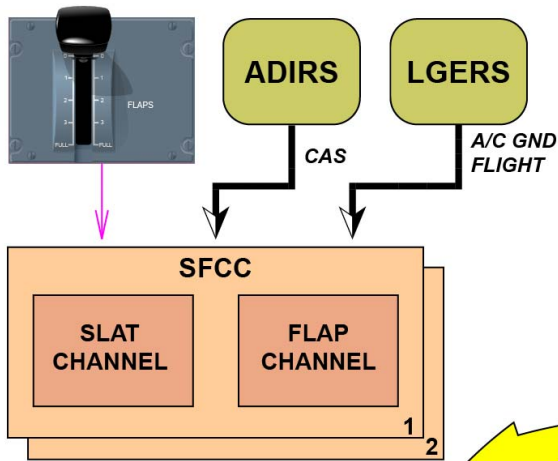

SLAT/FLAP CONFIGURATION TABLE

LEVEL POSITION	SLAT/FLAP SFLM	SLAT/FLAP POSITION	DN/SLAT POSITION	FLAP POSITION		FLIGHT PHASES
				INBOARD	OUTBOARD	
0		CLEAN	CLEAN	CLEAN	CLEAN	CRUISE
1		1	1	CLEAN		APPROACH (HIGH SPEED)
		1 + F	1	1 WITH DFS (1)	1 WITHOUT DFS (2)	TAKE-OFF (A/C ON GROUND) APPROACH (LOW SPEED)
2		2	1	2		TAKE-OFF (A/C ON GROUND) APPROACH (LOW SPEED)
3		3	1	2		TAKE-OFF (A/C ON GROUND)
		3 + S <sup>(3)</sup>	2	3		APPROACH LANDING
FULL		FULL	FULL	FULL	FULL	LANDING

AUTO-COMMAND FUNCTION

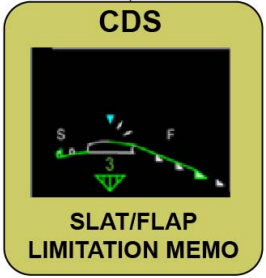

ADIRS: Air Data/Inertial Reference System  
 CAS: Calibrated Air Speed  
 DFS: Differential Flap Setting  
 DN: Droop Nose  
 SFCC: Slat Flap Control Computer  
 SFLM: Slat/Flap Limitation Memo

NOTE: (1) WITH DFS, INBOARD FLAP (10.5°) AND INBOARD FLAP (13.5°)  
 (2) WITHOUT DFS, INBOARD/OUTBOARD FLAP (12°)  
 (3) 3+S: VENTED SLATS

LIFT AND DRAG MANAGEMENT: TAKE-OFF AND LANDING PHASES

V1813401 - V01T0M0 - VM27DBPERFO3001

## AIRCRAFT PERFORMANCE OPTIMIZATION DESCRIPTION (3)

### **Lift and drag management: climb and cruise phases**

During the climb and cruise phases, the high lift system drive the flaps to optimize the A/C wing performance for:

- Drag reduction
- Lift/drag ratio
- Wing structural load-reduction
- Etc.

This performance optimization is possible when the settings that follow are used together:

- Uniform flap setting
- Inboard differential flap setting
- Outboard differential flap setting.

When the control lever is at position 0, the flaps setting orders are calculated by the Primary Flight Control System (PFCS), from A/C data (e.g. altitude, Mach number, dynamic pressure, A/C and fuel mass, etc.). The PFCS sends these commands to the SFCCs to generate a drive command.

A FLAPS lever position different from 0 will override the PFCS orders. When used together, the uniform flap setting and inboard differential flap setting can do the functions that follow:

- Control of the variable camber for a constant change of the wing camber
- Control of the wing load
- Lateral compensation (roll effect).

### **Variable camber function: uniform flap setting (+ inboard differential flap setting + outboard differential flap setting)**

In cruise, the variable camber function is done by the uniform flap setting (together with the inboard differential flap setting and outboard differential flap setting) to:

- Adjust the wing camber, to manage the centre of lift in the aft/forward position.

- Optimize the lift/drag ratio (for high Mach numbers), (drag minimization).

- Reduce the fuel consumption.

This function does small deflections during cruise, in limited range.

### **Wing load control: symmetrical inboard differential flap setting**

During the climb phase, this function adjusts the centre of lift on the wing spanwise toward the wing root (by extending the inboard flaps up to 4°) to:

- Optimize the load sharing on the wing structure (heavy weight)
- Alleviate the wing root bending-moment (for maneuver and in gust conditions).

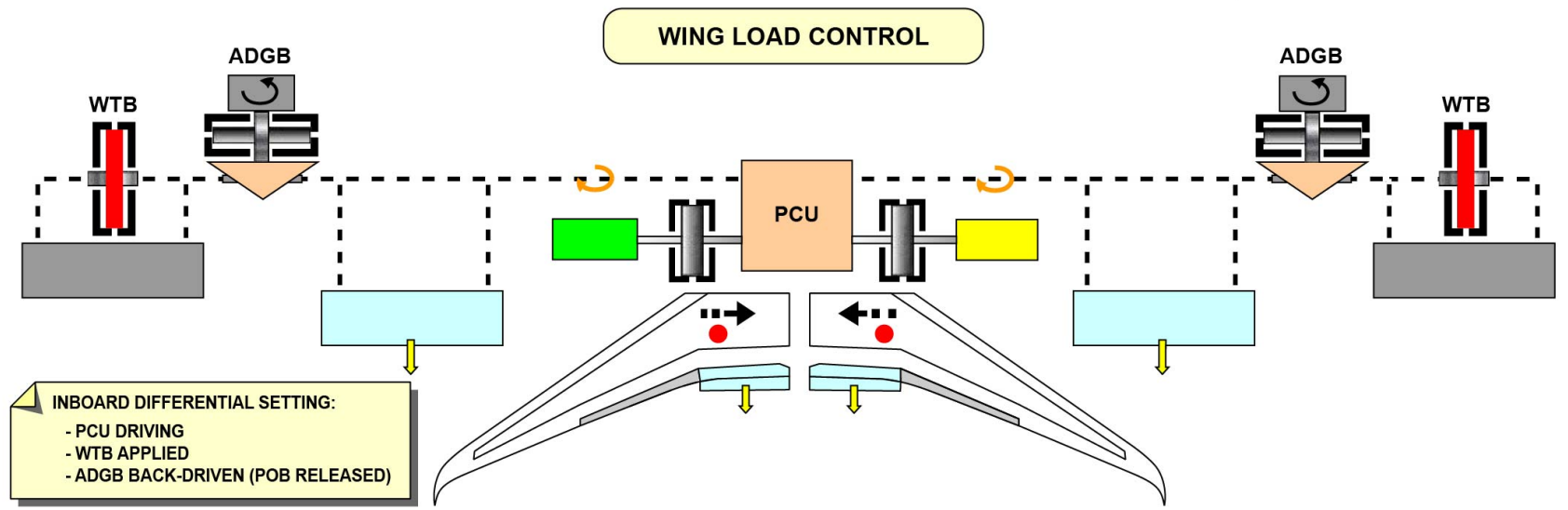
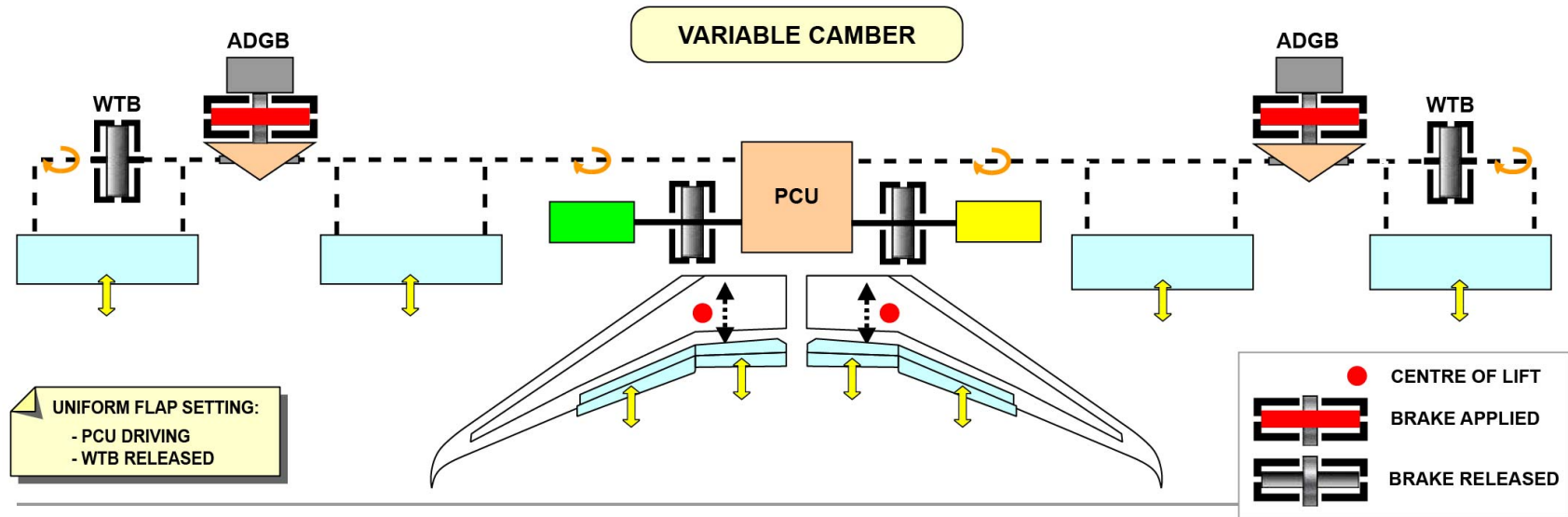

V1813401 - V01T0M0 - VM27DBPERFO3001

---

LIFT AND DRAG MANAGEMENT: CLIMB AND CRUISE PHASES - VARIABLE CAMBER FUNCTION: UNIFORM FLAP SETTING (+ INBOARD DIFFERENTIAL FLAP SETTING + OUTBOARD DIFFERENTIAL FLAP SETTING) & WING LOAD CONTROL: SYMMETRICAL INBOARD DIFFERENTIAL FLAP SETTING

This Page Intentionally Left Blank

---

## AIRCRAFT PERFORMANCE OPTIMIZATION DESCRIPTION (3)

### Lift and drag management: climb and cruise phases (continued)

#### **Lift/drag ratio control: symmetrical outboard differential flap setting**

The outboard differential flap setting (associated with the inboard differential flap setting) can be used for the variable camber function, in cruise. The purpose is to optimize the lift/drag ratio by moving the centre of lift in spanwise direction (drag minimization).

This function is also used after a classic uniform flap setting, during 1+F position at take-off (as given in LIFT and DRAG Management: TAKE-OFF and LANDING Phases).

#### **Lateral compensation: asymmetrical outboard differential flap setting**

A small unsymmetrical deployment of the outer flaps can be performed for lateral compensation and to protect roll authority in certain cases. The lateral compensation function does an outboard flap deflection (by 3° maximum).

This causes a roll effect which balances the A/C if there is:

- Lateral fuel imbalance
- One engine inoperative
- Some failures on specific servo-control actuators.

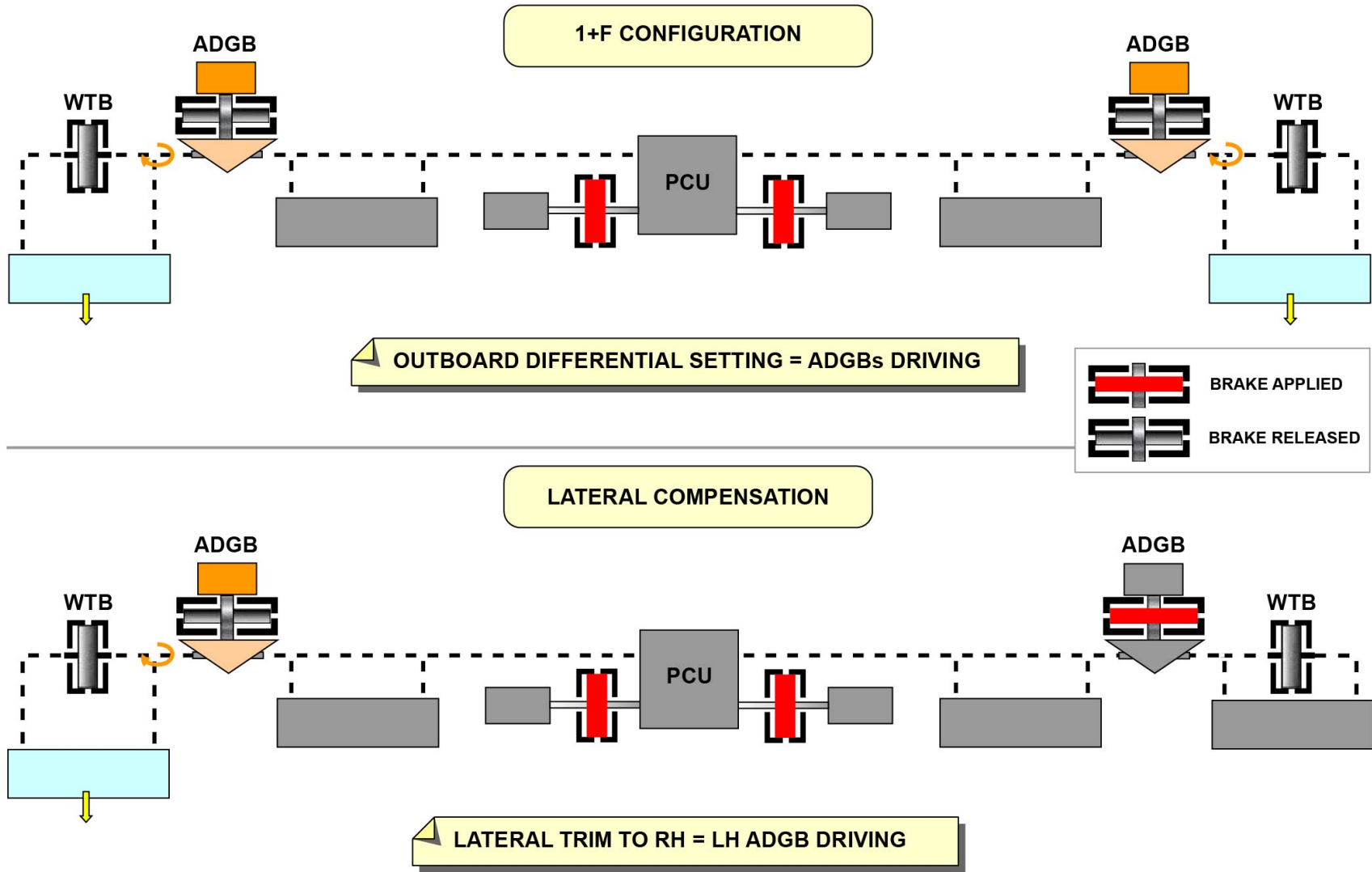

V1813401 - V01T0M0 - VM27DBPERFO3001

LIFT AND DRAG MANAGEMENT: CLIMB AND CRUISE PHASES - LIFT/DRAG RATIO CONTROL: SYMMETRICAL OUTBOARD DIFFERENTIAL FLAP SETTING & LATERAL COMPENSATION: ASYMMETRICAL OUTBOARD DIFFERENTIAL FLAP SETTING

---

## PROTECTION LAWS DESCRIPTION (3)

### **High Lift System Protection Functions**

The position of the slats and flaps is connected to a manual command from the control lever.

For flight safety reasons, the Slat Flap Control Computers (SFCCs) can change the position of the slats and flaps or prevent a manual command, automatically.

For these different protection functions, the SFCCs are in relation with the Air Data and Inertial Reference System (ADIRS).

The protection functions are:

- The slat baulk-function
- The slat alpha-lock-function
- The slat/flap load relief-function
- The slat auto command-function
- The slat/flap cruise baulk-function.

The protection engagements are shown on the slat/flap limitation memo.



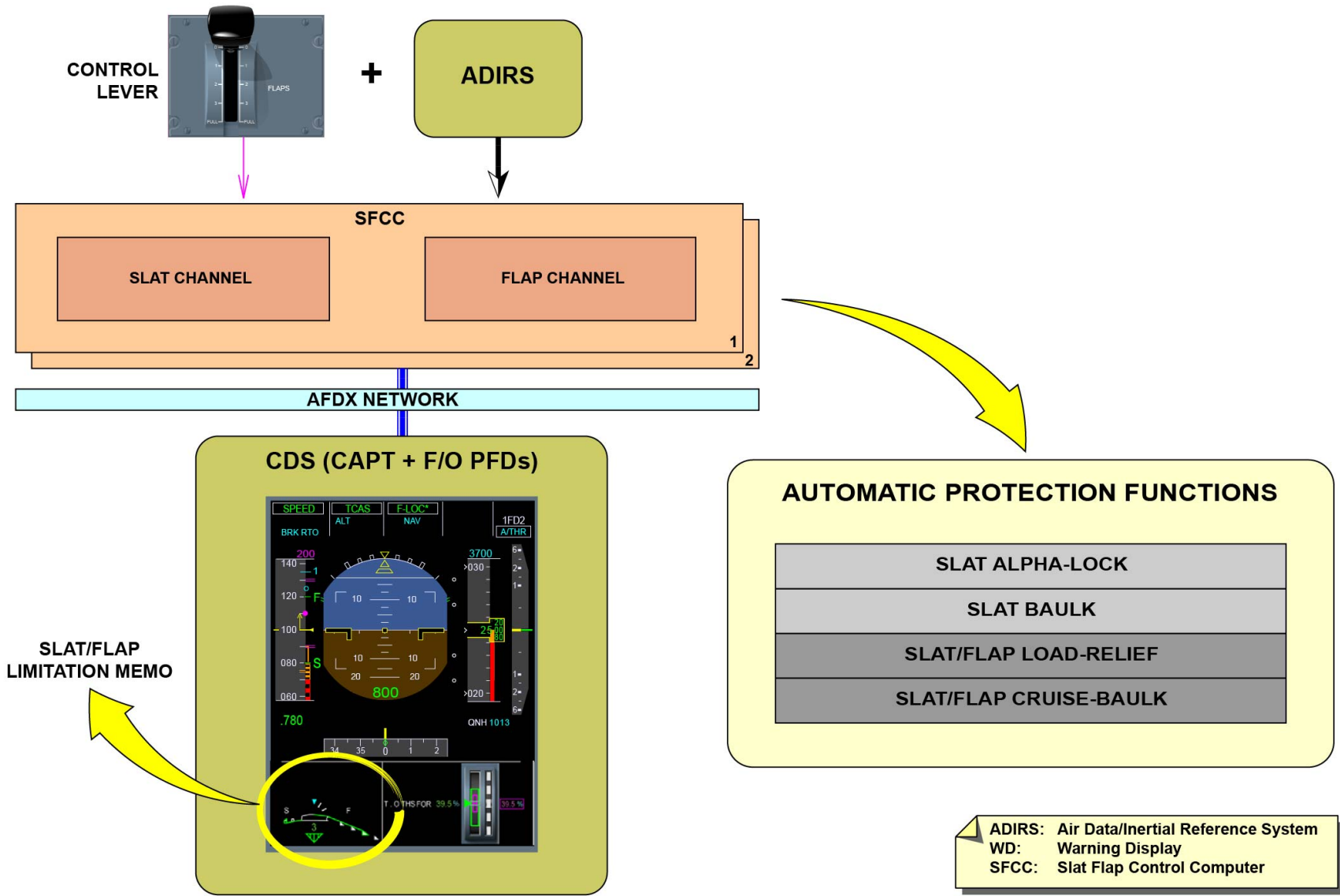

HIGH LIFT SYSTEM PROTECTION FUNCTIONS

V1813401 - V01T0M0 - VM27DCPROTE3001

## PROTECTION LAWS DESCRIPTION (3)

### Slat/Flap Protection Laws

#### Automatic protection functions for the slat

The following slat automatic control-functions are controlled in the slat channels of the SFCCs:

- Slat alpha-lock-function
- Slat baulk-function
- Slat cruise baulk-function
- Slat load relief-function.

#### Slat alpha-lock and baulk functions

The slat channels of the SFCCs receive the Angle Of Attack (AOA) and Calibrated Air Speed (CAS) from the ADIRS for the function computation.

In order to give an A/C protection from stall, the slat alpha-lock and baulk functions prevent the droop nose or slat retraction from the position 1 to the position 0, if:

- There is too much AOA ( $> 10.6^\circ$ ). It is the slat alpha-lock-function.
- The CAS falls below a threshold (140 kts). It is the slat baulk-function.

The slat/flap limitation memo area (under the PFD) shows an A LOCK indication when the slat alpha-lock or baulk function is engaged.

#### Slat cruise baulk-function

The slat cruise baulk-function prevents a droop nose or a slat extension during cruise when the FLAPS lever is (accidentally) moved from the position 0 to the position 1. A selection above 1 overrides this inhibition for an incorrect situation (direct law).

The function is engaged if the A/C Altitude (ALT) or the speed is higher than these thresholds (ALT  $> 22000$  ft or CAS  $> 265$  kts).

There is no indication on slat/flap limitation memo.

#### Slat load relief-function

The slat load relief-function gives a slat protection from the aerodynamic loads (CAS  $>$  maximum flap extended speed (VFE) +2.5 kts), when the FLAPS lever is in the position 1. This function

commands a slat retraction to a position in the middle between the configurations 1 and 0.

#### Automatic protection functions for flaps

These flap automatic control-functions are controlled in the flap channels of the SFCCs:

- Flap load relief-function
- Flap cruise baulk-function.

#### Flap load relief-function

The flap load relief-function is available when the FLAPS control lever is in position 2, 3 or FULL. A flap retraction to the next lower configuration is commanded if the aircraft speed is higher than the design limits (VFE + 2.5 kts).

There is no flap load relief-function with the lever in the position 1. Flap cruise baulk-function

The flap cruise baulk-function prevents a flap extension during cruise when the lever is (accidentally) moved from the position 0 to 1. A selection above 1 overrides this inhibition for an incorrect situation (direct law). The function is engaged if the A/C altitude or speed is higher than thresholds (ALT  $> 22000$  ft or CAS  $> 265$  kts).

There is no indication on the slat/flap limitation memo.

**SLAT/FLAP PROTECTION LAWS**

**LOW SPEED/HIGH AOA PROTECTIONS**

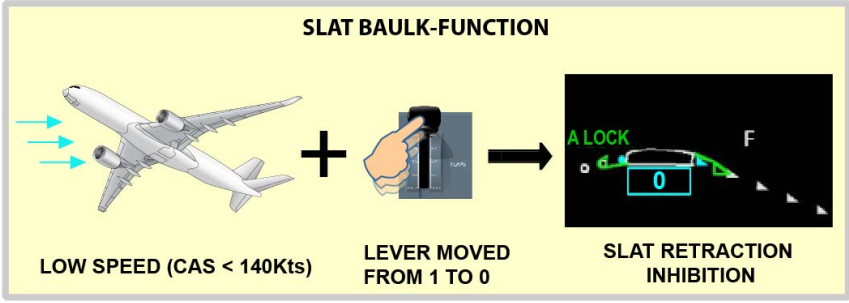
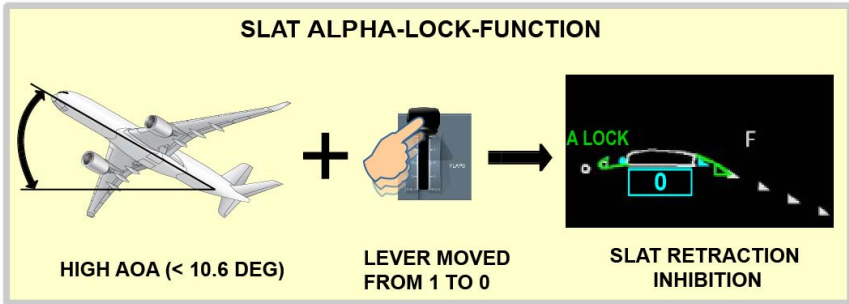

ALT: Altitude  
 AOA: Angle Of Attack  
 CAS: Computed Air Speed  
 MAX: Maximum  
 VFE: Maximum Flap Extended Speed

**HIGH SPEED AND ALTITUDE PROTECTIONS**

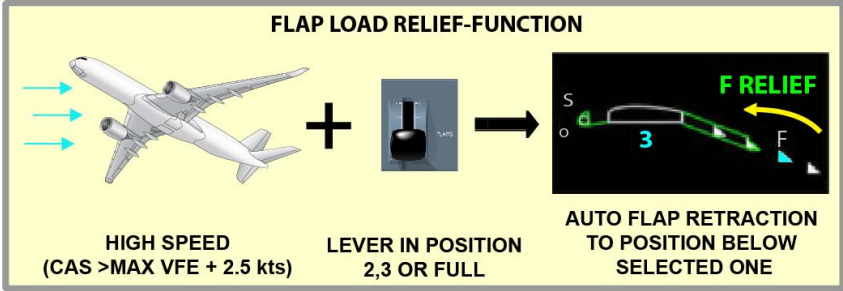
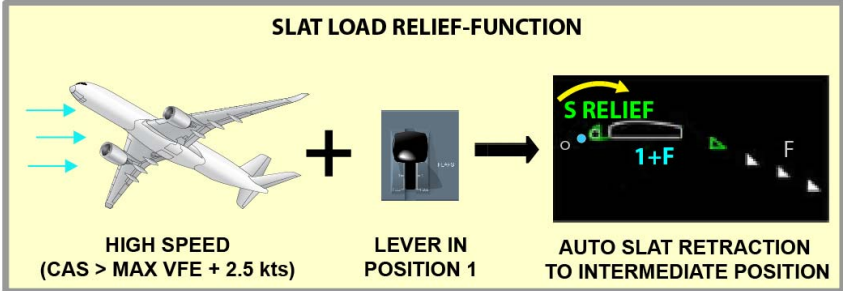
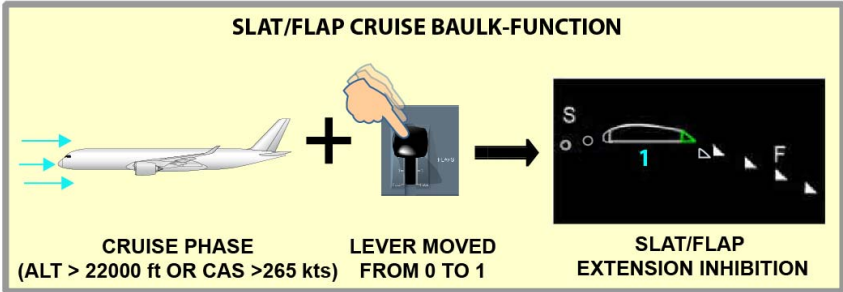

**SLAT/FLAP PROTECTION LAWS - AUTOMATIC PROTECTION FUNCTIONS FOR THE SLAT & AUTOMATIC PROTECTION FUNCTIONS FOR FLAPS**

V1813401 - V01T0M0 - VM27DCPROTE3001

## HIGH LIFT SYSTEM (HLS) CONTROL AND INDICATING (2/3)

### High Lift System - General (2)

FLAPS and SLATS normal extension

As we extend flaps with Flap Control Lever, 5 different positions can be selected. Depending on A/C configuration the flaps and slats will move to different deflection depending on the flight phase. Configuration 1 on ground is 1+F for T/O and will extend inboard Flaps to 10,5 and outboard to 13,5.

If the A/C is in flight and we select flaps position 1 for approaching will be also a 1+F and will extend both INNER and OUTER to 12, The same will happen if we are on ground before TO and DFS is not available.

When we select a new target, the number will be in a blue box and also the number will change the color from green to blue till new position is achieved by the flaps and slats.

### High Lift System Reset (2)

FLAPS and SLATS normal extension

High Lift system is composed of two computers SFCC (two systems), each of them has Slats and Flaps channel.

Only one SFCC is enough to control the whole system, if one SFCC is inoperative their associated PCU are not running, and the system is operated at half speed. An indication of the operation of the system is shown at the Flight Control ECAM page.

Each SFCC have two circuits breakers associated at the cockpit one for flap another for slat. You can reset each system individually.

### Slat Control Failure (3)

The leading edge high lift system contains 7 leading edge devices on each wing. The inboard device consists of one Droop Nose Device (DND) supported on 5 hinges with only two driven. The outboard devices consist of 6 Slat each supported and driven on two tracks. The outer slat (slat 7) is additionally supported on a third not driven track.

The slats are sealed against the wing leading edge. The droop nose device is driven via a 'plug-in type' rotary actuator with a drive link and lever assembly. The drive link is between drive lever and DN hinge arm. Each slat section is driven via a 'plug-in type' rotary actuator and a rack & pinion assembly. The rack is connected to the track

We can have the slats blocked by different failures, and depending on the type of failure that leads to slat blockage, indication on the ECAM will be different.

For the first malfunction Slats Locked, wing tip brakes are applied and SFLM show Slat Locked message.

For the other two malfunctions depend if you select only one, the system will be operated in half speed. But if you select both, system is shown faulty with and amber S indication in the SFLM and system is declared INOP.

Concerning the PCU the electrical motor will be commanded by the SFCC 1 and the Hydraulic motor by SFCC2.

Slat System is controlled by two SFCC, each of them powered by a bus, SFCC 1 slat channel will be powered by: 28 VDC-EMER 1, 230 VAC-EMER 1

Slat 1 computer is supplied by the 28 VDC-EMERG 1

Slat 1 is controlling the electric Motor of the Slat PCU supplied by the 230 VAC-EMER 1

SFCC 2: 28 VDC-NORM 2

Slat 2 is controlling the yellow hydraulic motor of the Slat PCU

Slat 2 computer is supplied by the 28VDC NORM 2

### Spoiler Droop Function Failure (3)

Flaps and spoilers are moved together without mechanical coupling; separate fly-by-wire actuation of spoiler and flap.

Due to the architecture of the flap system with a hinge rotational point, the mechanical gap between spoiler and flap need to be reduced by a spoiler droop which is controlled by a dedicated computer logic in the PRIM/SEC computers of the Primary Flight Control System (PFCS)

(max. possible spoiler droop: 10°). Droop panels and spoilers will follow the flaps movement to ensure fulfillment of gap/overlap requirements between wing trailing edge and flap leading edge. Spoiler adjustment to flaps position will be commanded by PFCS. Considering this input and the gap requirement for each flap setting the respective order for spoiler adjustment is determined by PFCS and executed such that no clash between flap and spoiler surfaces can happen.

FLAP RETRACT INHIBIT message at SFLM is shown if a spoiler does not allow the flaps to retract.

### **Flaps Control Failure (3)**

Power Control Units (PCUs) mounted in the fuselage drive the systems (one PCU for the slats, another one for the flaps). The flap PCU comprises two identical hydraulic motors working on a speed summing differential gear.

Within the flap transmission system on each wing there is an Active Differential Gearbox (ADGB) between inboard and outboard flap composed of an electric motor and a speed-summing differential gear, which introduces an additional power source for the outboard flaps. Due to this active gearbox the outboard flaps can be moved independently from the inboard flaps enabling Differential Flap Setting (DFS).

The Flap Cruise Deployment Function performs symmetrical small deflection (uniform and differential) during cruise in the limited range of -2° (flaps up) to +4° (flaps down) for the inner flap and -2° to +1° for the outer flap. Asymmetrical small deflections up to 3° are generating a roll effect and called lateral trim function. We can also use DFS for drag control that is the optimization of a/c drag by moving the centre of lift in spanwise direction by driving the outboard flaps symmetrically. An Active Differential Gearbox (ADGB) in the flap transmission between inboard and outboard flap allows performing Differential Flap Setting (DFS), thus no interconnection strut between inboard and outboard flap to enable DFS.

When we select a new target, the number will be in a blue box and also the number will change the color from green to blue till new position is achieved by the flaps and slats.

If ADGB is not in operation by a FAULT, a message is shown in the SFLM, the flaps operation are still possible but not availability of the differential flap setting. Message shown is DIFF FLAP in amber.

As a result of a all hydraulic system failure the PCU can not operate the flaps system and only ADGB is able to move outer flaps, in consequence a message of INNER FLAP LOCKED is shown at SFLM.

If flap system is locked, wing tip brakes are applied and a message showing that flap system is Locked is displayed in the SFLM.

### **Flaps Control Lever Failure (3)**

The high lift system is controlled and monitored by two Slat/Flap Control Computers (SFCCs). The pilot control commands are received from the flaps lever in the cockpit. Four Reset-Switches - one for each SFCC channel - are available for SFCC recovery.

The flight crew manually selects the flap/slat configuration for flight phases take-off, approach and landing through the cockpit mounted flaps lever. The flaps lever commands are sent to the SFCCs via Command Sensor Unit (CSU). The flap lever is composed of two CSU one for SFCC1 and the other for SFCC2, each CSU is composed of 4 isolated sensors and send information to its own SFCC, (2 for slats and 2 for Flaps on its associated SFCC) if a failure occurs in one sensors associated SFCC channel is declared INOP and the system may run half speed.

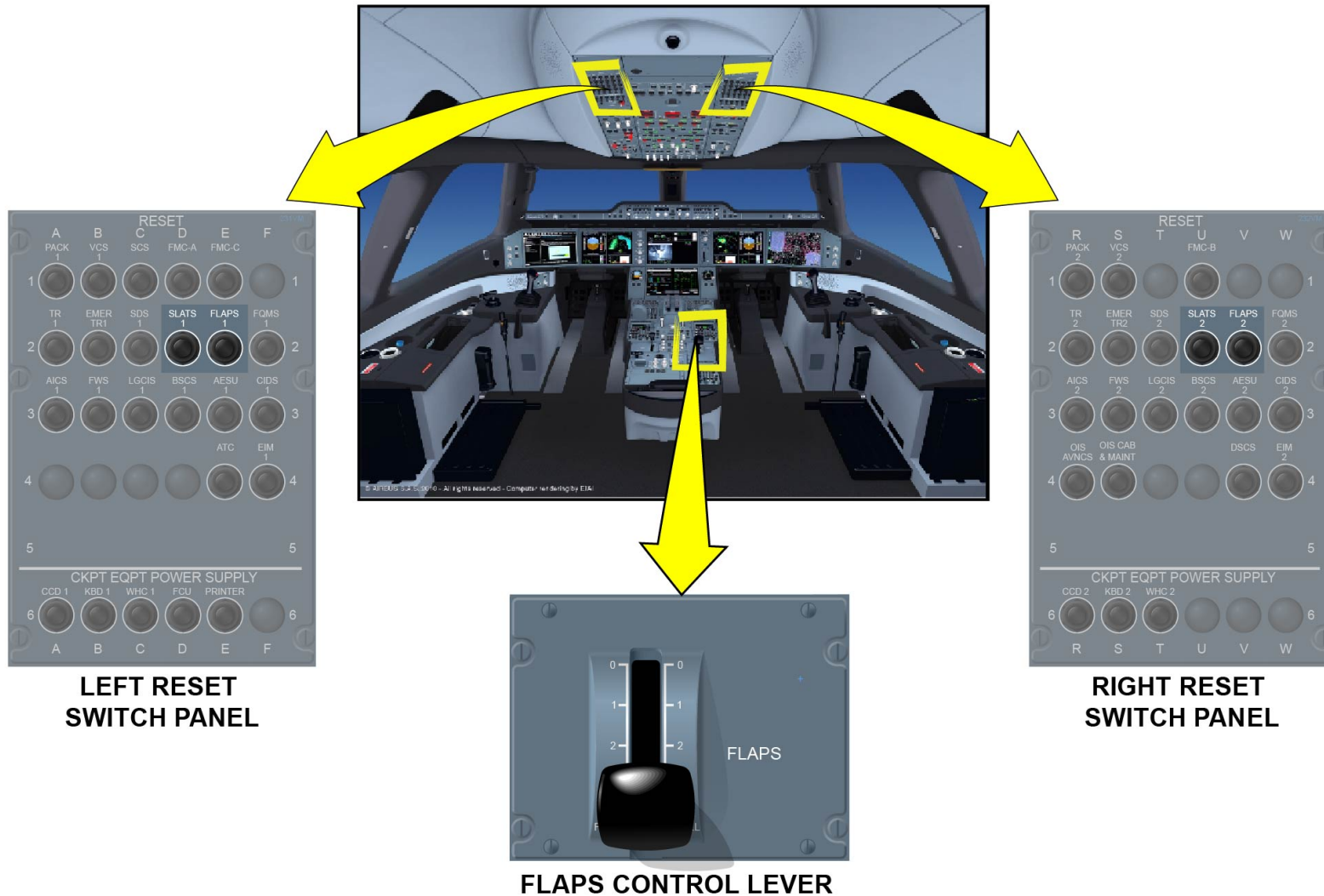

**LEFT RESET SWITCH PANEL**



**RIGHT RESET SWITCH PANEL**



**FLAPS CONTROL LEVER**

HIGH LIFT SYSTEM - GENERAL (2) ... FLAPS CONTROL LEVER FAILURE (3)

V1813401 - V01T0M0 - VM2712HLS003001



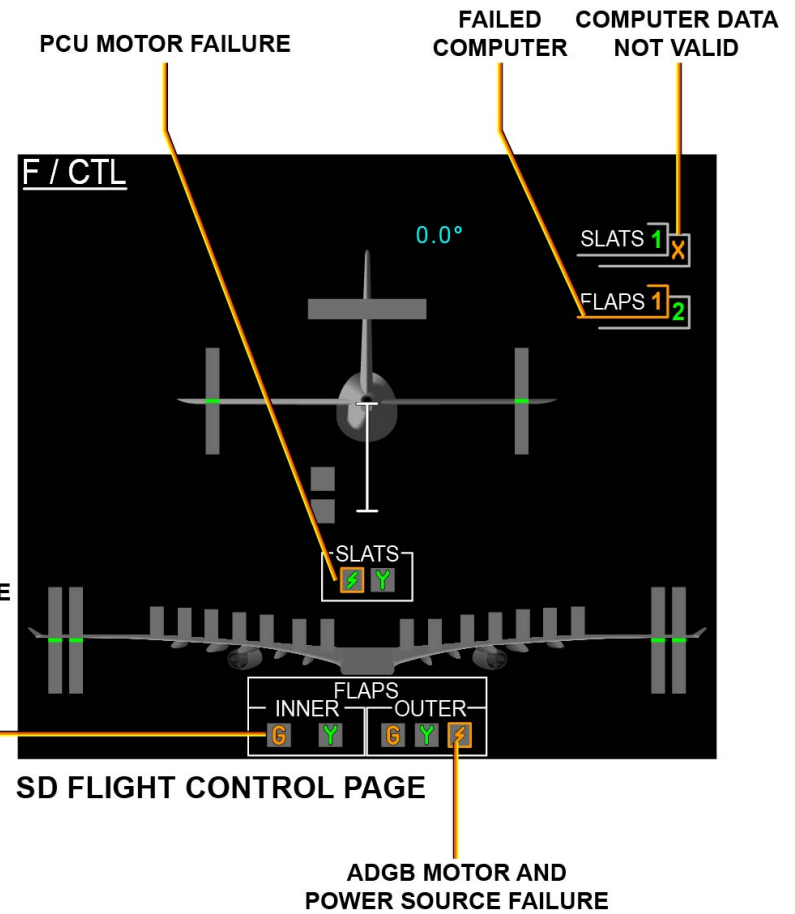
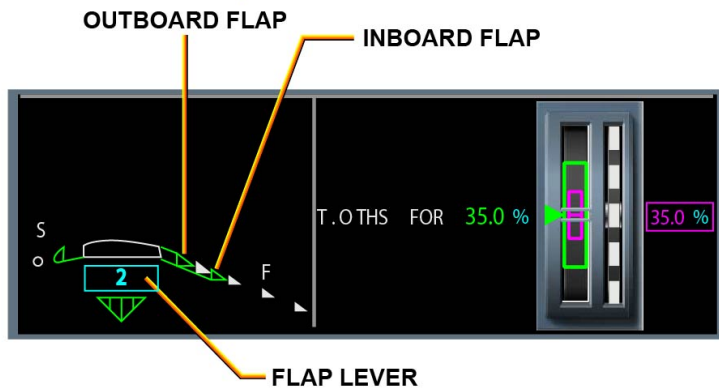

HIGH LIFT SYSTEM - GENERAL (2) ... FLAPS CONTROL LEVER FAILURE (3)

V1813401 - V01T0M0 - VM2712HLS003001

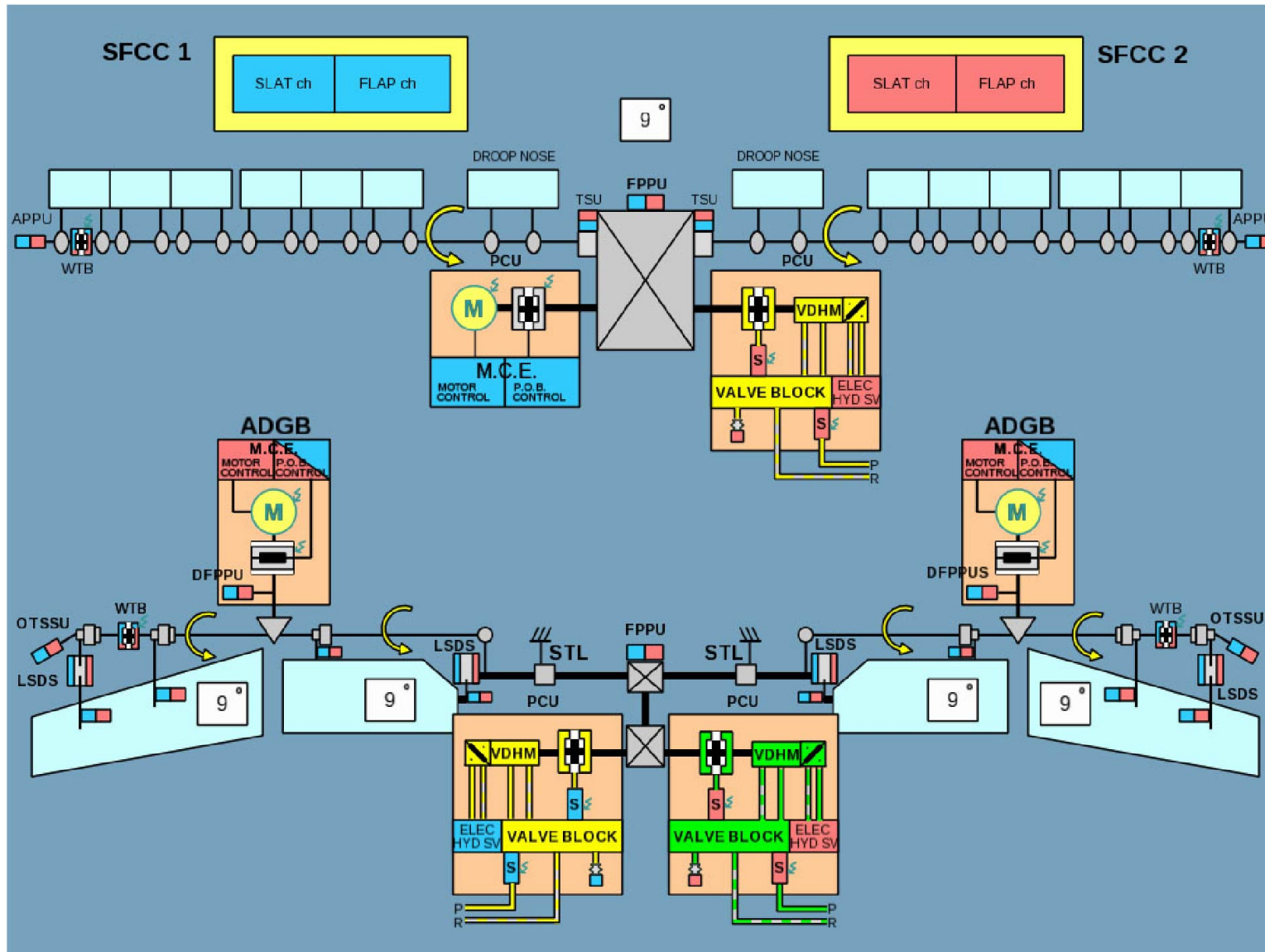

HIGH LIFT SYSTEM - GENERAL (2) ... FLAPS CONTROL LEVER FAILURE (3)

V1813401 - V01T0M0 - VM2712HLS003001



This Page Intentionally Left Blank

---

## HIGH LIFT SYSTEM (HLS) MAINTENANCE (2/3)

### **Wing Tip Brake: Special Tool**

The manual release tool releases the wing tip brake during maintenance operations, if there is no electrical power. The manual release tool has a special design, so that no standard tool can be installed. Once installed, the tool cannot be removed, when the Wing Tip Brake (WTB) is manually released.

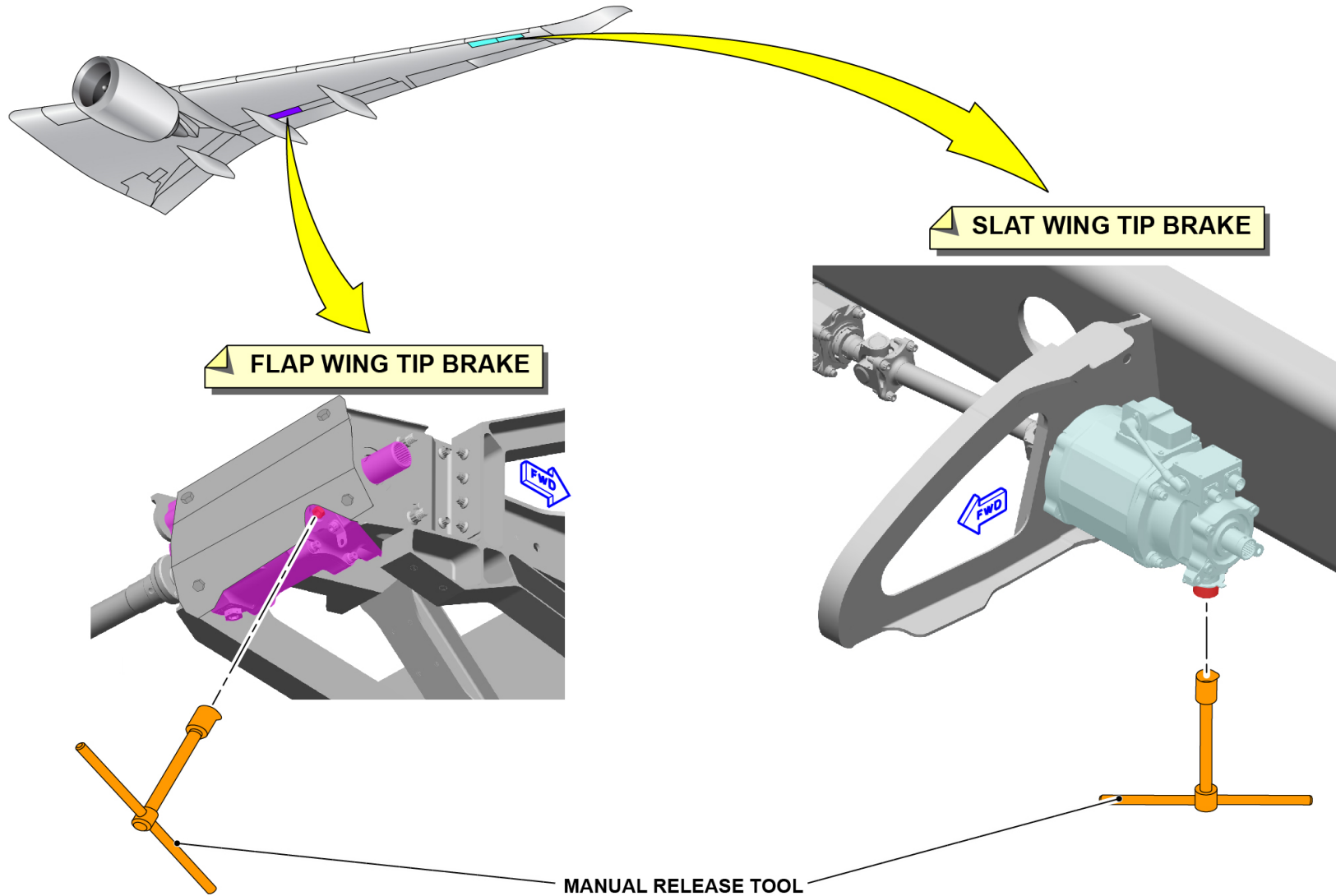

WING TIP BRAKE: SPECIAL TOOL

VI1813401 - V01T0M0 - VM27M2HLSMA3001

## HIGH LIFT SYSTEM (HLS) MAINTENANCE (2/3)

### Slat flap rigging procedure

Rigging is necessary, after some maintenance procedures.

For the slats, there is a mechanical nominal position for the setting, which depends on the limit gauge, to set the nominal position.

The following steps are followed:

- (1) Measure the surface trailing edge in retracted position with a slide caliper.
- (2) Manually extend a few degrees for access.
- (3) Manually retract the gauge as shown in the slide, until the gauge stops the strut.
- (4) Install the transmission shaft to set the rigged position.

For the droop nose, the gauge is used for extended and retracted positions, as shown. Rigging is done through the adjustment of the actuator with gauge-referencing retracted and extended end-stops.

For the flaps, the rigging can be done in the actuator itself and on the link between the actuator and the flap surface (drive strut).

For the actuator, a rigging pin is used to stop the actuator at the nominal position.

When the actuator is rigged, the drive strut can be rigged with a fixed rigging bar and through the adjustment of the drive strut to this length. Safety tip: the rigging pin and the rigging bar must be removed before flight.

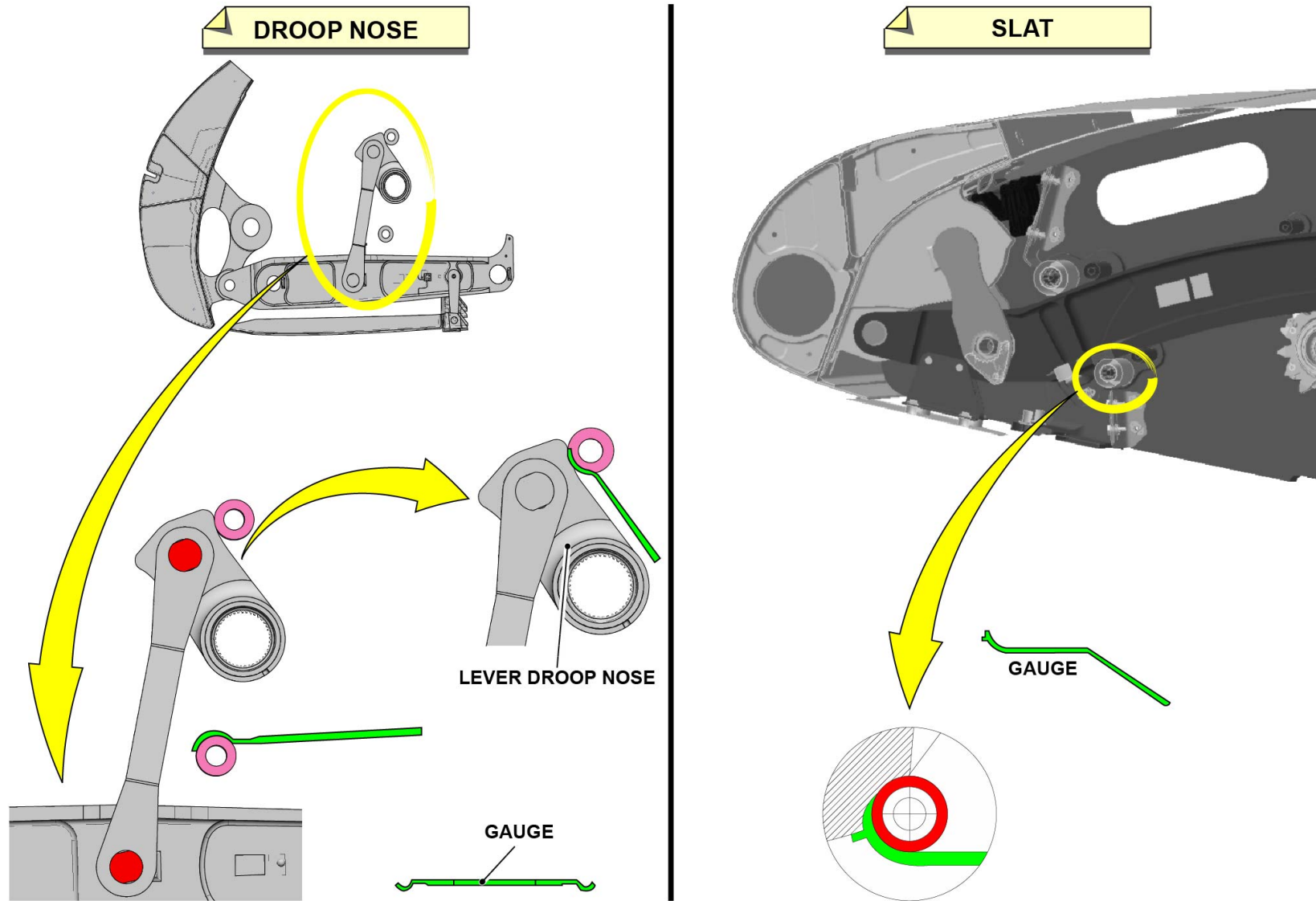

SLAT FLAP RIGGING PROCEDURE

VI1813401 - V01T0M0 - VM27M2HLSMA3001

**FLAP RIGGING**

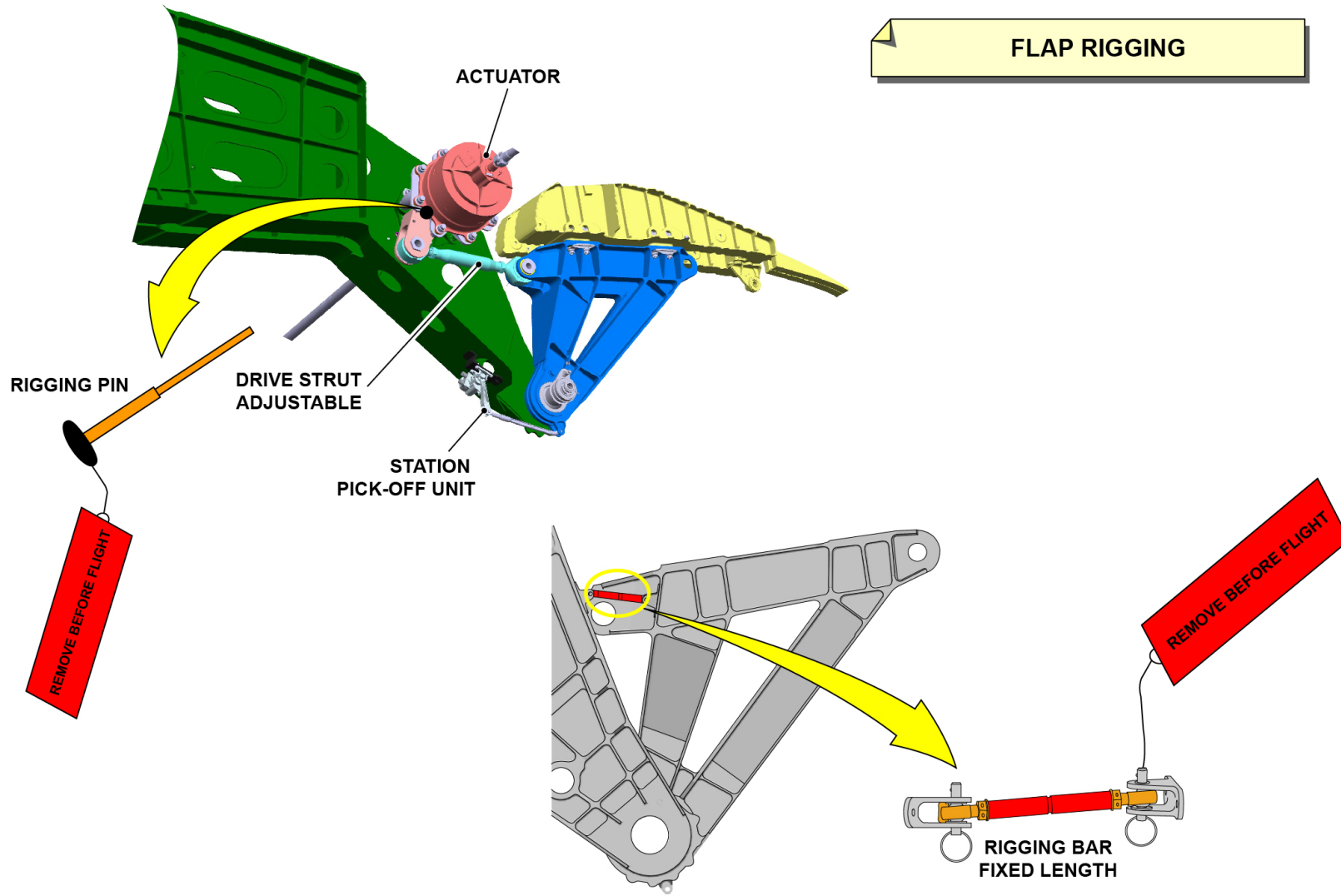

SLAT FLAP RIGGING PROCEDURE

V1813401 - V01T0M0 - VM27M2HL.SMA3001

This Page Intentionally Left Blank



**AIRBUS**  
AN EADS COMPANY

---

AIRBUS S.A.S.  
31707 BLAGNAC cedex, FRANCE  
STM  
REFERENCE V1813401  
OCTOBER 2013  
PRINTED IN FRANCE  
AIRBUS S.A.S. 2013  
ALL RIGHTS RESERVED

---

AN EADS COMPANY